

APJ ABDUL KALAM  
TECHNOLOGICAL  
UNIVERSITY

**SEMESTER V**

KTU



## CIVIL ENGINEERING

### CORE COURSES – S5

SLOT	COURSE NO.	COURSES	L-T-P	HOURS	CREDIT
A	CET301	STRUCTURAL ANALYSIS – I	3-1-0	4	4
B	CET303	DESIGN OF CONCRETE STRUCTURES	3-1-0	4	4
C	CET305	GEOTECHNICAL ENGINEERING – II	4-0-0	4	4
D	CET307	HYDROLOGY & WATER RESOURCES ENGINEERING	4-0-0	4	4
E	CET309	CONSTRUCTION TECHNOLOGY & MANAGEMENT	3-0-0	3	3
F	MCN301	DISASTER MANAGEMENT	2-0-0	2	--
S	CEL331	MATERIAL TESTING LAB – II	0-0-3	3	2
T	CEL333	GEOTECHNICAL ENGINEERING LAB	0-0-3	3	2
R/M/H	VAC	REMEDIAL/MINOR/HONOURS COURSE	3-1-0	4*	4
TOTAL				27/31	23/27

### MINOR COURSES - S5

R/M	CET381	STRUCTURAL MECHANICS	3-1-0	4	4
R/M	CET383	ECO-FRIENDLY TRANSPORTATION SYSTEMS	3-1-0	4	4
R/M	CET385	SUSTAINABILITY ANALYSIS & DESIGN	3-1-0	4	4

### HONOURS COURSES - S5

R/M/H	CET393	STRUCTURAL DYNAMICS	3-1-0	4	4
R/M/H	CET395	TRANSPORTATION SYSTEMS MANAGEMENT	3-1-0	4	4
R/M/H	CET397	GROUND WATER HYDROLOGY	3-1-0	4	4

CET301	STRUCTURAL ANALYSIS - I	CATEGORY	L	T	P	CREDIT	Year of Introduction
		PCC	3	1	0	4	2019

**Preamble:**

The course enables the students to analyse various types of simple structures using appropriate methods and tools. It introduces the applications of principles of mechanics of solids to determine stress resultants in statically determinate and indeterminate structures. Specific cases of cables, suspension bridges and arches are also discussed at length. The course trains the students to develop mathematical models and helps to sharpen their analytical skills. After this course students will be able to analyse structures subjected to moving loads as well.

**Prerequisite:** CET201 Mechanics of Solids

**Course Outcomes:** After the completion of the course the student will be able to

Course Outcome	Description of Course Outcome	Prescribed learning level
CO1	Apply the principles of solid mechanics to analyse trusses.	Applying
CO2	Apply energy principles to analyse statically determinate structures.	Applying
CO3	Identify the problems with static indeterminacy and understand the basic concepts of tackling such problems by means of the method of consistent deformations.	Understanding, Analysing
CO4	Apply suitable methods of analysis for various types of structures including cables, suspension bridges and arches.	Applying
CO5	Analyse the effects of moving loads on structures using influence lines.	Analysing
CO6	Apply specific methods such as slope deflection and moment distribution methods of structural analysis for typical structures with different characteristics.	Applying

**Mapping of course outcomes with program outcomes (Minimum requirement)**

	PO1	PO2	PO3	PO4	PO5	PO6	PO7	PO8	PO9	PO10	PO11	PO12
CO1	2	2	-	-	-	-	-	-	-	-	-	-
CO2	2	2	-	-	-	-	-	-	-	-	-	-
CO3	3	3	-	-	-	-	-	-	-	-	-	-
CO4	3	2	-	-	-	-	-	-	-	-	-	-
CO5	3	2	-	-	-	-	-	-	-	-	-	-
CO6	3	2	-	-	-	-	-	-	-	-	-	-

**Assessment Pattern**

Bloom's Category	Continuous Assessment Tests		End Semester Examination
	1	2	
Remember	10	05	10
Understand	20	10	20
Apply	30	25	50
Analyse	10	10	20
Evaluate			
Create			

**Mark distribution**

Total Marks	CIE	ESE	ESE Duration
150	50	100	3 hours

**Continuous Internal Evaluation Pattern:**

Attendance : 10 marks  
 Continuous Assessment Test (2 numbers) : 25 marks  
 Assignment/Quiz/Course project : 15 marks

**End Semester Examination Pattern:** There will be two parts; Part A and Part B. Part A contain 10 questions with 2 questions from each module, having 3 marks for each question. Students should answer all questions. Part B contains 2 questions from each module of which student should answer any one. Each question carries 14 marks and can have maximum 2 sub-divisions.

**Course Level Assessment Questions**

**CO1: Apply the principles of solid mechanics to analyse trusses.**

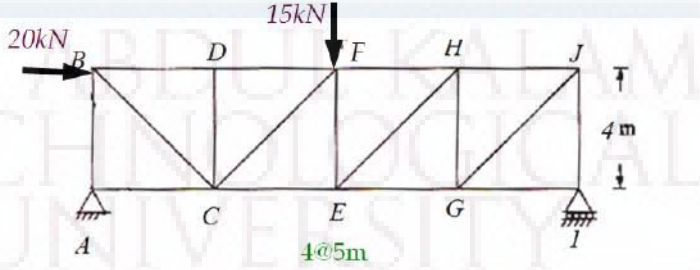
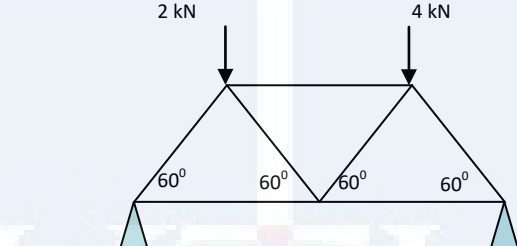
1.	Explain the method of joints to analyse trusses.
2.	<p>Find the member forces in FH, EH and EG using method of sections.</p> 
3.	<p>Analyse the truss in figure using method of joints</p> 

**CO2: Apply energy principles to analyse statically determinate structures.**

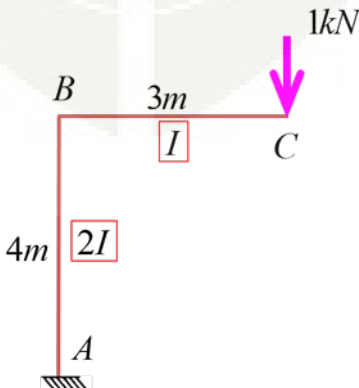
1.	Find from first principles, the shear strain energy in bending for a cantilever with uniform cross section, width 200mm, depth 300mm and span 3m. A point load of 10kN is acting at the free end. $E= 2 \text{ MN/m}^2$ .
2.	State and prove Betti's Theorem.
3.	Find the bending strain energy for a cantilever of span 3m with a point load of 10kN at the free end. Cross section is 200X300mm. $E= 2 \text{ MN/m}^2$ .
4.	<p>Find the vertical deflection at C for the frame in figure using strain energy method.</p> 

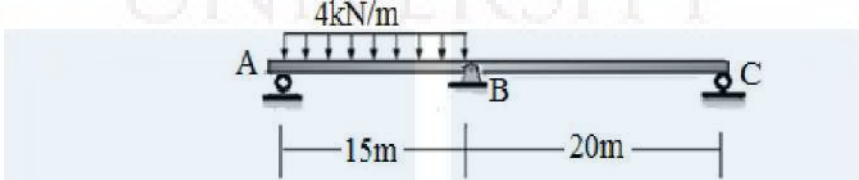
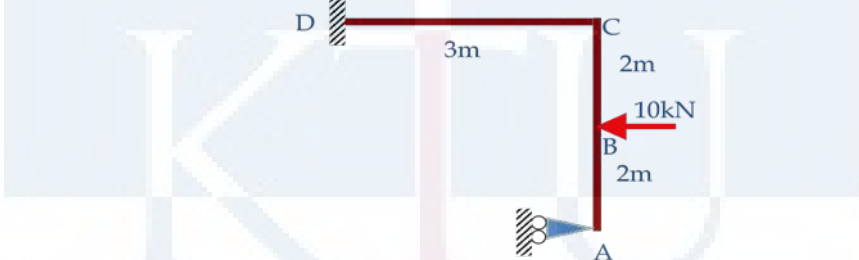
<b>CO3:</b>	<b>Identify the problems with static indeterminacy and understand the basic concepts of tackling such problems by means of the method of consistent deformations.</b>
1.	Explain static and kinematic indeterminacies with examples.
2.	Differentiate between force and displacement methods for analysing indeterminate structures
3.	Find the reaction at B for the beam shown in figure, using consistent deformation method. 
4.	Analyse the 2D frame using consistent deformation method (EI is constant). 

**CO4: Apply suitable methods of analysis for various types of structures including cables, suspension bridges and arches.**

1.	Write a note on three-hinged and two-hinged stiffening girders.
2.	State and explain Eddy's theorem
3.	For a cable AB, the level difference between the supports A and B is 6m, and the lowest point is at a vertical distance of 4.5m from A. If the horizontal span AB is 24m and is loaded with 7.5kN/m throughout the span, find the length of the cable, and the minimum and maximum tension in the cable
4.	A suspension bridge with 25m span and central dip 2.5m transfers 4kN per horizontal metre to each cable. Find max and min pull in each cable, and the length of cable
5.	The span of the 3-hinged parabolic arch shown in figure is 30m and the rise is 6m. Find BM, normal thrust, and radial shear at a section 7.5 m from the left hinge. Find maximum BM on the arch.

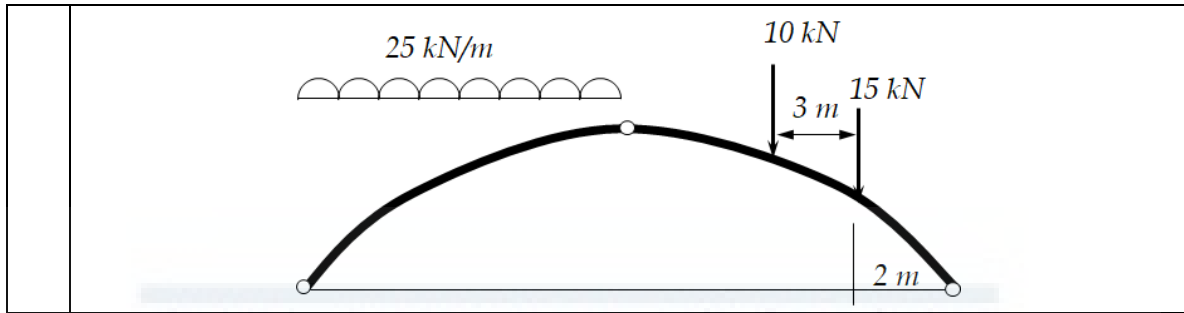

**CO5: Analyse the effects of moving loads on structures using influence lines.**

1.	State and explain the condition for absolute maximum bending moment in a simple beam when a series of concentrated loads is moving across it
2.	What are influence lines? Draw ILD for SF and BM at any intermediate section of a simply supported beam. What are the uses of influence lines?
3.	Four point loads 30kN, 40kN, 20kN and 15kN, distance between them being 2m, are moving across a simple beam (of span 15m) from left to right with 30kN load leading. Find position of the loads for maximum -ve SF and BM at a section 7m from left end. Also find maximum -ve SF and BM at the section.

**CO6: Apply specific methods such as slope deflection and moment distribution methods of structural analysis for typical structures with different characteristics.**

1.	Explain briefly on the analysis of frames with sidesway, using slope deflection method
2.	Derive expressions for stiffness at the near-end for a beam with hinged far-end
3.	Analyse the continuous beam using slope deflection method (EI is constant). <div style="text-align: center;"> </div>
4.	Analyse the continuous beam in figure using moment distribution method (EI is constant)

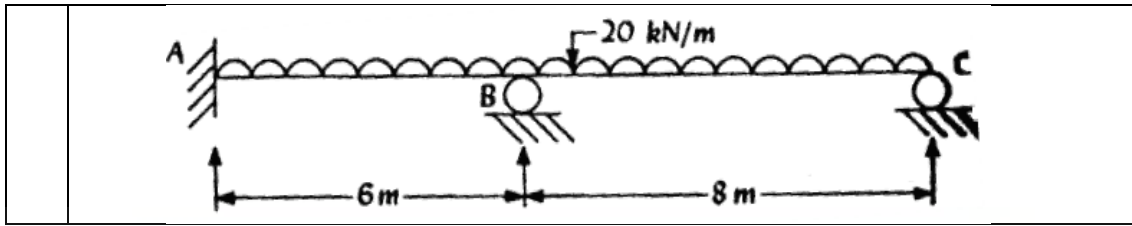

API ABDUL KALAM  
TECHNOLOGICAL  
UNIVERSITY

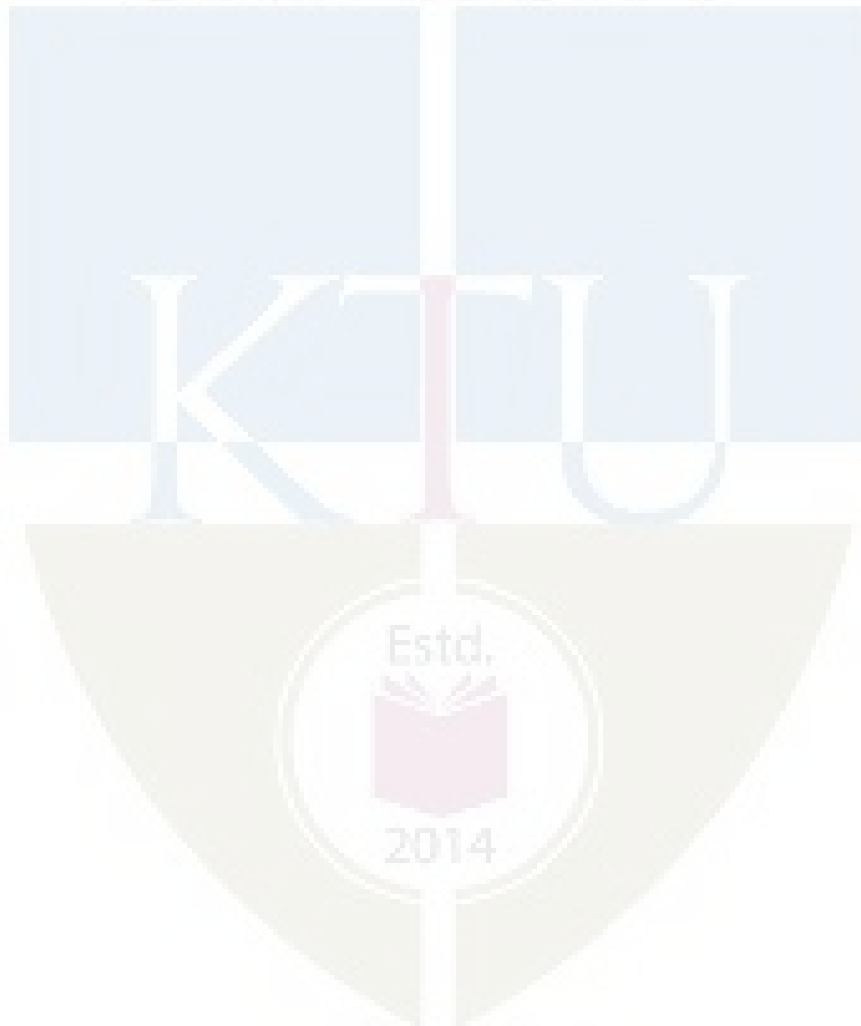



**SYLLABUS****Module – 1*****Statically determinate structures:***

Trusses: Method of joints and method of sections (Numerical problems) – 4 hrs.

Elastic theorems and energy principles: strain energy due to axial load, bending moment, shear and torsion - strain energy method, Castigliano's method for deflection (Derivations only). – 4 hrs.

Betti's theorem – Maxwell's law of reciprocal deflections - 1 hr.

**Module – 2**

Principle of least work; Application of unit load method and strain energy method for determination of deflection of statically determinate beams, frames - pin jointed trusses (simple numerical problems) – 4 hrs.

Concepts of temperature effects and lack of fit (No numerical problems) – 1 hr.

***Statically indeterminate structures:***

Degree of static and kinematic indeterminacies – Introduction to force and displacement methods - 1 hr.

Method of Consistent deformations: Analysis of beams frames and trusses with internal and external redundancy (Simple problems with maximum one redundant – Illustration only for two redundants)– 3 hrs.

**Module – 3**

Method of Consistent deformations (continued): Concepts of effect of prestrain, lack of fit, temperature changes and support settlement. (No numerical problems) – 1 hr.

***Cables:*** Analysis of forces in cables under concentrated and uniformly distributed loads - Anchor Cable supports – 4hrs.

***Suspension Bridges:*** Un-stiffened suspension bridges, maximum tension in the suspension cable and backstays, pressure on towers – 4 hrs.

**Module – 4**

***Arches:*** Theory of arches – Eddy's theorem - analysis of three hinged arches-Support reactions-normal thrust and radial shear at any section of a parabolic arch due to simple cases of loading. – 4 hrs.

**Moving loads and influence lines:** Introduction to moving loads - concept of influence lines - influence lines for reaction, shear force and bending moment in simply supported beams and over hanging beams - analysis single concentrated load, several concentrated loads, uniformly distributed load shorter and longer than the span. – 5 hrs.

### Module – 5

**Slope Deflection Method:** Analysis of continuous beams and portal frames without sway. Frames with sway (illustration only). Settlement effects (derivation only) – 4hrs.

**Moment Distribution Method:** Analysis of beams and frames – non sway analysis. Sway analysis (illustration only) – 4 hrs.

Introduction to structural analysis softwares (hands on exercises on two simple structural analysis problems) – 1 hr.

### Text Books:

1. Gere and Timoshenko, Mechanics of materials, CBS Publishers
2. Kenneth Leet, Chia M Uang & Anne M Gilbert, Fundamentals of Structural Analysis, McGraw Hill
3. R.Vaidyanathan and P.Perumal, Comprehensive Structural Analysis Volume I & II, Laxmi Publications (P) Ltd

### References:

1. Wang C.K., Intermediate Structural Analysis, McGraw Hill
2. Aslam Kassimali., Structural Analysis, Cenage Learning
3. Chandramouli P N, Structural Analysis I –Analysis of Statically Determinate Structures, Yes DeePublishing Pvt Ltd.,Chennai,Tamil Nadu.
4. DevdasMenon, Structural Analysis, Narosa Publications
5. Hibbeler., Structural Analysis, Pearson Education
6. Kinney S., Indeterminate Structural Analysis, Oxford & IBH
7. M.L. Gambhir, Fundamentals of structural Mechanics and analysis, Printice Hall India
8. Reddy C.S., Indeterminate Structural Analysis, Tata McGraw Hill
9. Timoshenko S.P.& Young D.H., Theory of Structures, McGraw Hill
10. Daniel L Schodak, Structures, Pearson Education, 7e, 2014
11. Negi L. S. and Jangid R. S, Structural Analysis, Tata McGraw Hill, 1997
12. Rajasekaran S. and Sankarasubramanian G., Computational Structural Mechanics, PHI, 2008
13. S.S. Bhavikatti, Structural Analysis II, Vikas Publication Houses (P) Ltd, 2016
14. Utku S, Norris C. H & Wilbur J. B, Elementary Structural Analysis, McGraw Hill, 1990

## Lecture Plan –Structural Analysis I

Module	Topic	Course Outcomes addressed	No. of Lectures
<b>1</b>	<b>Module I: Total lecture hours: 9</b>		
1.1	Statically determinate and indeterminate structures - introduction	CO3	1
1.2	Trusses: Method of joints	CO1	2
1.3	Trusses: Method of sections (Numerical problems).	CO1	1
1.4	Elastic theorems and energy principles: introduction	CO2	1
1.5	Strain energy due to axial load, bending moment, shear and torsion	CO2	2
1.6	Strain energy method, Castigliano's method for deflection (Derivations only).	CO2	1
1.7	Betti's theorem – Maxwell's law of reciprocal deflections.	CO2	1
<b>2</b>	<b>Module II: Total lecture hours: 9</b>		
2.1	Principle of least work; Application of unit load method for determination of deflection of statically determinate beams, frames - pin jointed trusses (simple numerical problems)	CO2	2
2.2	Application of strain energy method (simple numerical problems)	CO2	1
2.3	Application of unit load method and strain energy method: Concepts of temperature effects and lack of fit (No numerical problems)	CO2	1
2.3	Statically indeterminate structures: Degree of static and kinematic indeterminacies - examples – Introduction to force and displacement methods.	CO3	2
2.4	Method of Consistent deformations: Analysis of beams frames and trusses with internal and external redundancy (Simple problems with maximum one redundant – Illustration only for two redundants)	CO3	3
<b>3</b>	<b>Module III: Total lecture hours: 9</b>		
3.1	Method of Consistent deformations: Effect of prestrain, lack of fit, temperature changes and support settlement.	CO3	1

	(No numerical problems)		
3.2	Cables: Analysis of forces in cables under concentrated and uniformly distributed loads	CO4	3
3.3	Anchor Cable supports	CO4	1
3.4	Suspension Bridges: Un-stiffened suspension bridges, maximum tension in the suspension cable and backstays, pressure on towers.	CO4	4
<b>4</b>	<b>Module IV: Total lecture hours: 9</b>		
4.1	Arches: Theory of arches – Eddy's theorem	CO4	1
4.2	Analysis of three hinged arches-Support reactions-normal thrust and radial shear at any section of a parabolic arch due to simple cases of loading	CO4	3
4.2	Moving loads and influence lines: Introduction to moving loads - concept of influence lines	CO5	1
4.3	Influence lines for reaction, shear force and bending moment in simply supported beams and over hanging beams	CO5	1
4.4	Analysis single concentrated load, several concentrated loads, uniformly distributed load shorter and longer than the span. Conditions for maximum shear and bending moment.	CO5	3
<b>5</b>	<b>Module V: Total lecture hours: 9</b>		
5.1	Slope Deflection Method: Concept and derivation of basic equations	CO3, CO6	1
5.2	Slope Deflection Method: Analysis of continuous beams and portal frames without sway.	CO6	2
5.3	Slope Deflection Method: Frames with sway (illustration only). Settlement effects (derivation only)	CO6	1
5.2	Moment Distribution Method: Concept and derivation of basic equations	CO3, CO6	1
5.3	Moment Distribution Method: Analysis of beams and frames – non sway analysis.	CO6	2
5.4	Moment Distribution Method: Sway analysis (illustration only)	CO6	1
5.3	Introduction to structural analysis software (hands on exercises on two simple structural analysis problems)	CO3	1

**MODEL QUESTION PAPER**

Reg.No.: \_\_\_\_\_

Name: \_\_\_\_\_

**APJ ABDUL KALAM TECHNOLOGICAL UNIVERSITY**  
**FIFTH SEMESTER B.TECH DEGREE EXAMINATION**

**Course Code: CET301**

**Course Name: STRUCTURAL ANALYSIS-I**

Max. Marks: 100

Duration: 3 Hours

**PART A**

*Answer all questions; each question carries 3 marks.*

1. a) Explain static and kinematic indeterminacies with examples.
- b) State and prove Betti's Theorem.
- c) Explain the method of consistent deformations, with an example.
- d) Differentiate between force and displacement methods for analysing indeterminate structures.
- e) Explain how problems involving temperature change/lack of fit are solved using consistent deformation method.
- f) Write a note on three-hinged and two-hinged stiffening girders.
- g) State and explain the condition for absolute maximum bending moment in a simple beam when a series of concentrated loads is moving across it.
- h) State and explain Eddy's theorem.
- i) Explain briefly on the analysis of frames with sidesway, using slope deflection method.
- j) Derive expressions for stiffness at the near-end for a beam with hinged far-end.

(10×3 marks = 30 marks)

**PART B**

*Answer one full question from each module; each full question carries 14 marks.*

**Module I**

2. a. Find the member forces in FH and EH and EG using method of sections.

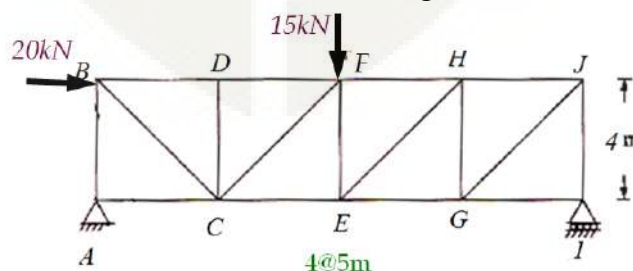

(6 marks)

- b. Analyse the truss in figure using method of joints.

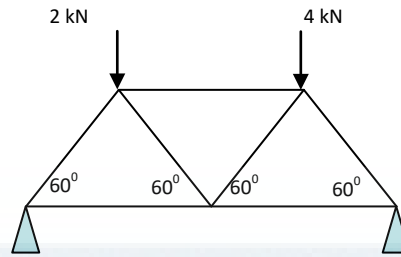

(8 marks)

3. a. Find the bending strain energy for a cantilever of span 3m with a point load of 10kN at the free end. Cross section is 200X300mm.  $E= 2 \text{ MN/m}^2$ . (7 marks)
- b. Find from first principles, the shear strain energy in bending for a cantilever with uniform cross section, width 200mm, depth 300mm and span 3m. A point load of 10kN is acting at the free end.  $E= 2 \text{ MN/m}^2$ . (7 marks)

**Module II**

4. a. Find the deflection at E of the truss in figure, using unit load method. Cross-sectional areas of members are  $1200\text{mm}^2$ .  $E= 200 \text{ kN/mm}^2$ .

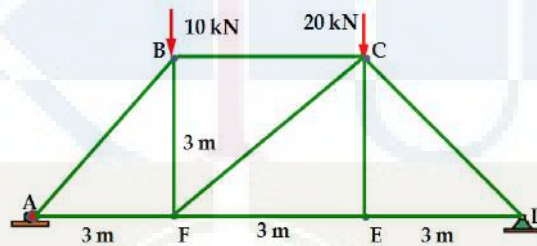

(7 marks)

- b. Find the vertical deflection at C for the frame in figure using strain energy method

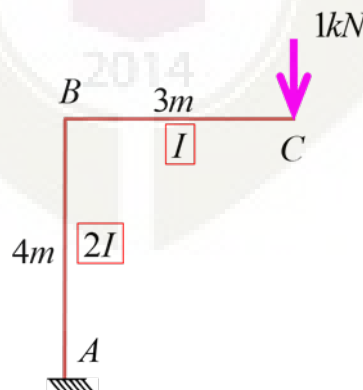

(7 marks)

5. a. Find the reaction at B for the beam shown in figure, using consistent deformation method.

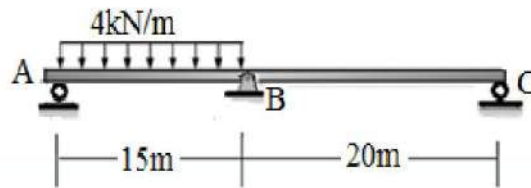

(7 marks)

- b. Analyse the 2D frame using consistent deformation method (EI is constant).

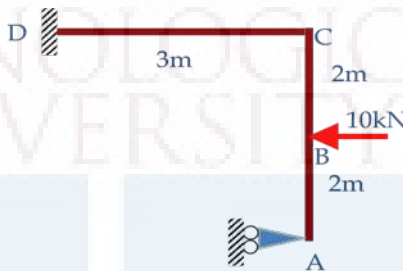

(7 marks)

### Module III

6. For a cable AB, the level difference between the supports A and B is 6m, and the lowest point is at a vertical distance of 4.5m from A. If the horizontal span AB is 24m and is loaded with 7.5kN/m throughout the span, find the length of the cable, and the minimum and maximum tension in the cable. (14 marks)
7. A suspension bridge with 25m span and central dip 2.5m transfers 4kN per horizontal metre to each cable. Find max and min pull in each cable, and the length of cable. (14 marks)

### Module IV

8. The span of the 3-hinged parabolic arch shown in figure is 30m and the rise is 6m. Find BM, normal thrust, and radial shear at a section 7.5 m from the left hinge. Find maximum BM on the arch.

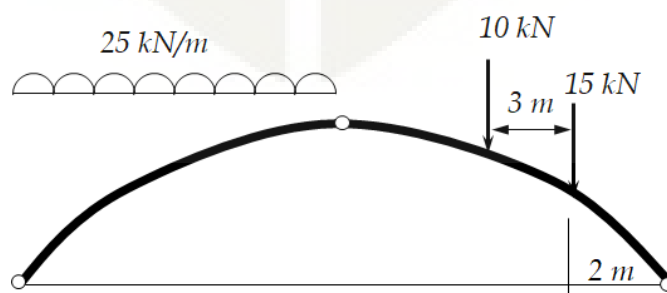

(14 marks)

9. a) What are influence lines? Draw ILD for SF and BM at any intermediate section of a simply supported beam.(5 marks)
- b) Four point loads 30kN, 40kN, 20kN and 15kN, distance between them being 2m, are moving across a simple beam (of span 15m) from left to right with 30kN load leading. Find position of the loads for maximum -ve SF and BM at a section 7m from left end. Also find maximum -ve SF and BM at the section. (9marks)

**Module V**

10. Analyse the continuous beam using slope deflection method (EI is constant).

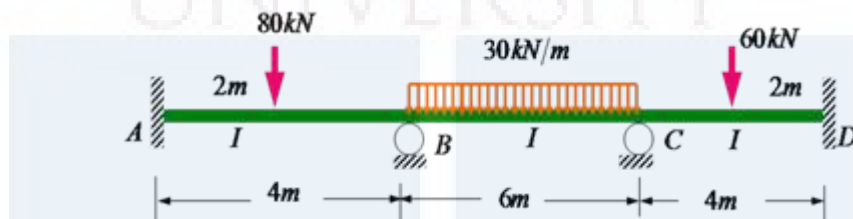

(14 marks)

11. Analyse the continuous beam in figure using moment distribution method (EI is constant).

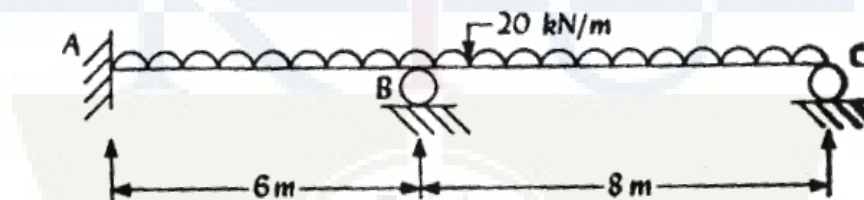

(14 marks)

\*\*\*\*\*

2014





## Assessment Pattern

CIVIL ENGINEERING

Bloom's Category	Continuous Assessment Tests		End Semester Examination
	1	2	
Remember			
Understand	10	10	30
Apply	30	30	60
Analyse	10	10	10
Evaluate			
Create			

## Mark distribution

Total Marks	CIE	ESE	ESE Duration
150	50	100	3 hours

## Continuous Internal Evaluation Pattern:

Attendance : 10 marks

Continuous Assessment Test (2 numbers) : 25 marks

Assignment/Quiz/Course project : 15 marks

**End Semester Examination Pattern:** There will be two parts; Part A and Part B. Part A contain 10 questions with 2 questions from each module, having 3 marks for each question. Students should answer all questions. Part B contains 2 questions from each module of which student should answer any one. Each question carries 14 marks and can have maximum 2 sub-divisions.

## Course Level Assessment (Sample) Questions

**CO1: Recall the fundamental concepts of limit state design and code provisions for design of concrete members under bending, shear, compression and torsion.**

1. Explain the term limit state design.
2. Enumerate the five limit states commonly used in limit state design and state briefly how they are provided for in design.
3. Define the term partial safety factor as used in limit state design. Identify the various factors and state the values recommended in IS 456
4. Explain the term 'factored load' and 'characteristic loads. Why IS 456 specifies the same partial safety factor for dead and live loads? Is it technically correct?
5. How are the following factors incorporated in design formulae for limit design
  - (a) partial safety factor for load,
  - (b) partial safety factor for material strength,

- (c) difference between cube strength and strength of concrete in structure.
6. Explain the basis for the selection of partial load and safety factors by the Code for serviceability limit states
  7. Why is the partial safety factor for concrete ( $\gamma_c$ ) greater than that for reinforcing steel ( $\gamma_s$ ) in the consideration of ultimate limit states?
  8. Explain the necessity for specifying maximum and minimum tension steel in reinforced beams. What are their values?
  9. What is equivalent shear as applied to torsion and shear in IS 456?
  10. Explain the terms 'balanced', 'over reinforced' and 'under reinforced' section. Explain which of these should be recommended in design. How is this ensured in design of beams according to IS 456?
  11. Why is it necessary to put a limit on the  $x/d$  allowed in singly reinforced beams as stipulated in IS 456? Can this condition be relaxed for beams with compression steel? Give reasons for your answer
  12. What are the types of reinforcements used to resist shear? Explain the action of different types of shear steel in resisting shear.
  13. What is meant by equivalent length of a column? Explain how column behaviour is affected by the effective length.
  14. Why is it necessary to have lateral ties in a column?
  15. How do helically reinforced columns differ from tied columns in their behaviour? In what situations would one recommend the use of helically reinforced column?

**CO2: Analyse reinforced concrete sections to determine the ultimate capacity in bending, shear and compression.**

1.	A rectangular beam 250mm wide and effective depth 450 mm has 4 bars of 20mm diameter. Find the moment of resistance of the section if M20 concrete and Fe 415 grade steel are used. As per IS 456:2000 find the limiting moment of resistance also.
2.	A rectangular RC beam 230 mm wide and 420 mm effective depth is reinforced with 2-16mm diameter bars at top and 4 – 16 mm bars at bottom. Estimate the ultimate moment carrying capacity of the section assuming M20 concrete and Fe415 steel.
3.	A rectangular beam 250mm wide and effective depth 450 mm has 4 bars of 20mm diameter. 8mm diameter two legged vertical stirrups are provided at 200 mm c/c. Determine the ultimate SF the section can resist. Assume M20 concrete and Fe415 steel.
4.	A square column 300 mm x 300 mm is reinforced with 8 bars of 16 mm diameter. Assuming M25 concrete and Fe415 steel, determine the safe axial load carrying capacity of the column

**CO3: Design and detail beams, slab, stairs and footings using IS code provisions.**

1. Design a simply supported beam of span 6m subjected to a live load of 4 kN/m. Use M20 concrete and Fe415 steel.
2. Design a simply supported rectangular beam to carry a superimposed load of 30kN/m over a span of 5.5m. Assume support width as 300mm. Maximum overall depth is restricted to 550mm. Use M20 concrete and Fe 415 grade steel.
3. Design a slab for a room of size 3mx5.5m carrying a live load of 7 kN/m<sup>2</sup>. Use M20 concrete and Fe 415 grade steel. Assume that the corners are held down. The slab is having all the four edges discontinuous
4. Design a square isolated footing for a column of size 400mm x 400mm carrying a load of 1500 kN under service conditions. Safe bearing capacity of soil is 200 kN/m<sup>2</sup>. Use M20 concrete and Fe 415 grade steel.
5. Design and detail an isolated rectangular footing for a column 400 mm x 600 mm to carry a load of 2000 kN. The SBC of the soil is 180 kN/m<sup>2</sup>. Use M20 concrete and Fe 415 grade steel
6. A dog-legged staircase for a residential flat consists of 18 steps, each of 300 mm tread 180 mm rise, with an intermediate landing 1.2 m in width at the middle. The width of staircase is also 1.2 m. If the flights are of equal number of steps, design the staircase detail the steel.  $f_{ck} = 20 \text{ N/mm}^2$  and  $f_y = 415 \text{ N/mm}^2$ .
7. Explain the design detail of a combined rectangular footing with reinforcement details.

**CO4: Design and detail columns using IS code and SP 16 design charts.**

1. Design a RCC rectangular column to carry an axial load of 1200 kN and a moment of 70 kNm, The length of the column is 3.5m. The one end is fixed and the other end is hinged. The width of the column is restricted to the wall thickness of 24 cm.
2. Design a reinforced concrete column to carry an axial load of 1600 kN. Use M20 concrete and Fe415 steel. The column has unsupported length of 3m and is effectively held in position at both the ends, but not restrained against rotation.
3. Design and detail a column under biaxial bending with the following data:  
 Size of column = 40 x 60cm  
 The column is effectively held in position at both ends but not restrained against rotation. The unsupported length of column is 3.5m  
 Concrete grade = M20  
 Grade of Steel = Fe 415  
 Factored load  $P_u = 1900 \text{ kN}$   
 Factored Moment  $M_{ux} = 150 \text{ kNm}$  and  $M_{uy} = 110 \text{ kNm}$
4. A short column 300 mm x 600 mm is carrying an axial working load of 750 kN and a moment of 160 kNm at an axis bisecting the depth. Design the reinforcement required if  $f_y = 250 \text{ N/mm}^2$  and  $f_{ck} = 20 \text{ N/mm}^2$ , Also sketch the reinforcement.

**CO5: Explain the criteria for earthquake resistant design of structures and ductile detailing of concrete structures subjected to seismic forces.**

1. What are the objectives of earthquake-resistant design of reinforced concrete structures?
2. What are the objectives behind the special detailing provisions in IS 13920?
3. Distinguish between ordinary moment resisting frame (OMRF) and special moment resisting frame (SMRF)
4. How do you fix the minimum width of columns of moment resisting frames in Zone III?
5. What are the design requirements of beam-column joints?
6. What is meant by special confining reinforcement in columns of ductile frames?
7. What are the design requirements of beam-column joints in earthquake resistant design?

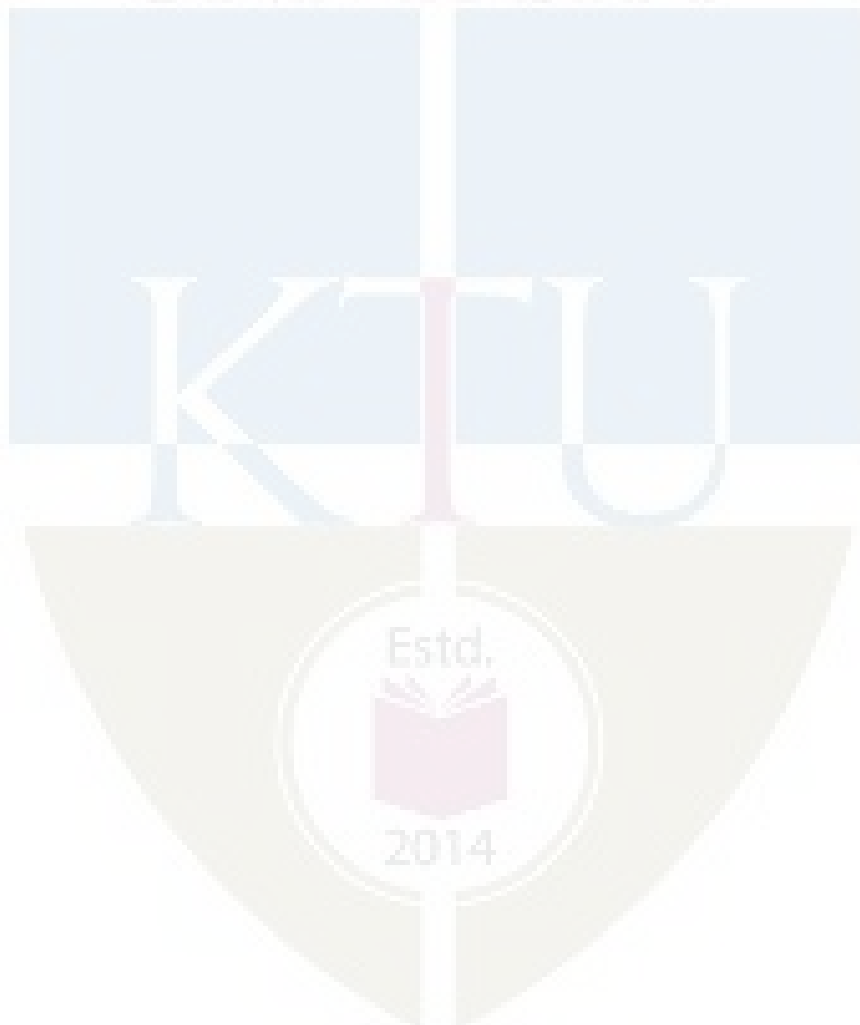

# SYLLABUS

CIVIL ENGINEERING

## Module I

Introduction – Limit states – Limit state of collapse in flexure – Analysis and design of singly reinforced beams.

## Module II

Analysis & design of doubly reinforced beams. Analysis of T-beams . Limit state of collapse in shear. Bond and development length.

## Module III

Design of slabs – one way and two way slabs. Design of stair case.

## Module IV

Limit state of collapse – compression, Design of axially loaded short column.

Design of short columns subjected to compression and uniaxial/biaxial bending- design using SP16 charts.

## Module V

Design of isolated and combined footings.

Limit state of serviceability.

Introduction to earthquake resistant design. Codal provisions – IS 1893, IS 13920

## Text Book:

1. Punmia, B. C, Jain A.K and, Jain A.K , R C C Designs, Laxmi Publications Ltd., 10e, 2015

## References:

1. Pillai S.U & Menon D – Reinforced Concrete Design, Tata McGraw Hill Book Co., 2009
2. Varghese P.C, Limit State Design of Reinforced Concrete, Prentice Hall of India Pvt Ltd, 2008
4. Relevant IS codes (IS 456, IS 875, IS 1893, IS 13920, SP 16, SP 34)

## Lecture Plan –Design of Concrete Structures

Module	Topic	Course Outcomes addressed	No. of Lectures
<b>1</b>	<b>Module I : Total lecture hours : 9</b>		
1.1	Introduction – Principles of Limit state method of design, Introduction to BIS code- Types of limit states-characteristic and design values-partial safety factors-types of loads and their factors.	CO1	2
1.2	Limit State of Collapse by flexure -assumptions-stress-strain relationship of steel and concrete-	CO1	2

1.3	Analysis of singly reinforced rectangular beams-balanced-under reinforced-over reinforced sections-moment of resistance codal provisions	CO2	2
1.4	Design of singly reinforced rectangular beams- basic rules for design-.	CO3	1
1.5	Design example of simply supported beam- design of cantilever beam-detailing	CO3	2
<b>2</b>	<b>Module II : Total lecture hours : 9</b>		
2.1	Analysis of doubly reinforced beams	CO2	1
2.2	Design of doubly reinforced beams –detailing,	CO3	1
2.3	T-beams- terminology- Formulae for analysis of T beams- examples –	CO1,CO2	2
2.4	Limit state of collapse in shear and bond- shear stresses in beams-types of reinforcement-shear strength of RC beam-IS code recommendations for shear design-	CO1	2
2.5	Design of shear reinforcement-examples	CO3	1
2.6	Bond and development length - anchorage for reinforcement bars - code recommendations regarding curtailment of reinforcement	CO1, CO3	1
2.7	Design for torsion-IS code approach- examples	CO3	1
<b>3</b>	<b>Module III : Total lecture hours : 10</b>		
3.1	Design of slabs- introduction- one-way and two-way action of slabs - load distribution in a slab-	CO1,CO3	1
3.2	IS recommendations for design of slabs- design of one-way slab- numerical problems – concepts of detailing of continuous slab –code coefficients.	CO1,CO3	2
3.3	Two- way slabs- simply supported design using IS Code coefficients Reinforcement detailing	CO1,CO3	2
3.4	Two- way slabs- restrained slabs – design using IS Code coefficients Reinforcement detailing	CO1,CO3	2
3.5	Stair cases- Types-proportioning-loads- distribution of loads – codal provisions –Concepts of tread-riser type stairs (detailing only)	CO1,CO3	1
3.6	Design and detailing of dog legged stair-	CO1,CO3	2
<b>4</b>	<b>Module IV : Total lecture hours : 9</b>		
4.4	Columns- introduction –classification- effective length-short column - long column - reinforcement-IS specifications regarding columns- limit state of collapse: compression -	CO1,CO4	1
4.5	Design of axially loaded short columns-design examples	CO4	2

	with rectangular ties		
4.6	Design of axially loaded short columns-design examples with helical reinforcement	CO4	2
5.1	Analysis and design of short columns subjected to compression and uniaxial bending- design using SP16 charts for limit state	CO4	2
5.2	Analysis and design of short columns subjected to combined axial load and biaxial bending moments-code procedure for design- design using SP16 charts for limit state	CO2,CO4	2
<b>5</b>	<b>Module V : Total lecture hours : 11</b>		
5.3	Foundations- classification-IS code provisions for design of isolated footings-	CO1, CO3	2
5.4	Design principles of rectangular footings- detailing.	CO1, CO3	2
5.5	Combined footings (design principles only)- analysis of combined footings-rectangular and trapezoidal.	CO1, CO3	2
4.1	Limit state of serviceability - limit state of deflection- short term and long term deflection-	CO1	1
4.2	Limit state of serviceability - IS code recommendations- limit state of cracking- estimation of crack width- simple numerical examples	CO1	2
4.3	Introduction to earthquake resistant design, Importance of Ductility in Seismic Design, Major Design Considerations, Codal provisions – IS 1893, IS 13920	CO5	2





Reg. No.: \_\_\_\_\_

Name: \_\_\_\_\_

**APJ ABDUL KALAM TECHNOLOGICAL UNIVERSITY**  
**FIFTH SEMESTER B.TECH DEGREE EXAMINATION**

**Course Code: CET303**

**Course Name: Design of Concrete Structures**

Max. Marks: 100

Duration: 3 Hours

**PART A**

*Answer all questions; each question carries 3 marks.*

1.
  - a) Derive the limiting values of depth of neutral axis for different grades of steel
  - b) Define characteristic strength & partial safety factor for materials. Why is partial safety factor for material high for concrete than steel?
  - c) Explain the term development length and explain its significance in RC design. obtain the expression for it
  - d) Explain why and how shear reinforcement is provided in beams
  - e) Explain the difference in the behaviour of one-way and two-way slabs. Why it is essential to provide corner reinforcement in two way rectangular slabs whose corners are prevented from lifting up?
  - f) What is meant by stair supported on landings? Explain the codal provision for the effective span of the stair slab in such cases?
  - g) What are the objectives behind the special detailing provisions in IS 13920?
  - h) Compare the behaviour of tied columns with spiral column subject to axial loading.
  - i) Explain how interaction curves are used in the design of column
  - j) Explain at what situations a combined footing is recommended.

**(10×3 marks = 30 marks)**

**PART B**

*Answer one full question from each module; each full question carries 14 marks.*

**Module I**

2.
  - (a) Explain balanced, under reinforced and over reinforced sections in the context of Limit State Design of Reinforced Concrete structures. **(4 marks)**
  - (b) A rectangular beam 250mm wide and effective depth 450 mm has 4 bars of 20mm diameter. Find the moment of resistance of the section if M20 concrete and Fe 415 grade steel are used. As per IS 456:2000 find the limiting moment of resistance also. **(10 marks)**
3.
  - (a) Explain the term Limit State. Enumerate the different limit states to be considered in reinforced concrete design. **(4 marks)**
  - (b).Design and detail an RC rectangular section subjected to a udl of 15 kN/m over the entire span. Clear span is 5m. The beam is supported on masonry walls, 230 mm thick on

both sides. Assume moderate exposure conditions. Use M 25 grade concrete and Fe 415 grade steel.(10 marks)

## CIVIL ENGINEERING

### Module II

4. (a) Enumerate the situations in which a doubly reinforced section become necessary. Derive expression for the ultimate moment of resistance of doubly reinforced section Explain. (4 marks)
- (b) Determine the ultimate moment of resistance of a doubly reinforced rectangular section of width 300 mm and overall depth 700 mm reinforced with 4 – 25mm diameter bars on tension side and 2 – 25mm diameter bars on compression side. Assume effective cover of 45 mm on both sides. Use M 20 concrete and Fe 415 steel.(10 marks)
5. (a) The provision of minimum stirrup reinforcement is mandatory in all reinforced concrete beams. Why?(2 marks)
- (b) Determine the ultimate moment of resistance of an isolated beam of T-shaped cross-section having a span of 6m and cross sectional dimensions are flange width of 1000mm, flange thickness of 100mm, web width of 250mm and an effective depth of 520mm, having tension reinforcement of 6 x 28mm diameter bars. The materials used are concrete mix of grade M20 and mild steel of grade Fe 415. (12 marks)

### Module III

6. (a) Distinguish between one way slab and two way slab. (2 marks)
- (b) Design and detail a simply supported slab for a room of interior dimension 5m x 4m subjected to an imposed load of 8 kN/m<sup>2</sup>. Thickness of supporting wall is 230 mm. Use M 20 concrete and Fe 415 grade steel.(12 marks)
7. (a) Explain the behavior of two way slabs and also the need of corner reinforcement in two way rectangular slabs whose corners are prevented from lifting.(3 marks)
- (b) Design a staircase to be provided in a residential building in two straight opposite flights of 1.0m width connected by a landing for a floor height of 3.3m. The landing which is 1m wide spans in the same direction as the stair slab. The rise and tread shall be 150mm and 270mm respectively. The weight of finishes 1kN/m<sup>2</sup>, live load =3kN/m<sup>2</sup>. M20 concrete & Fe415 steel are to be used.(11 marks)

### Module IV

8. (a)Classify the columns separately based on loadings and slenderness ratios.(4 marks)
- b)Design a reinforced concrete column to carry an axial load of 1600 kN. Use M20 concrete and Fe415 steel. The column has unsupported length of 3m and is effectively held in position at both the ends, but not restrained against rotation.(10 marks)
9. a)Draw four typical strain profiles of a short, rectangular and symmetrically reinforced concrete column causing collapse subjected to different pairs of  $P_u$  and  $M_u$  when the depths of the neutral axis are (i) less than the depth of column  $D$ , (ii) equal to the depth of column  $D$ , (iii)  $D < x_u < \infty$  and (iv)  $x_u = \infty$ . Explain the behaviour of column for each of the four strain profiles. (4 marks)

(b) Design a RCC rectangular column to carry an axial load of 1200 kN and a moment of 70 kNm, The length of the column is 3.5m. The one end is fixed and the other end is hinged. The width of the column is restricted to the wall thickness of 24 cm.(10 marks)

### Module V

10. (a) Design a footing for a 400 mm x 400 mm column to carry a load of 100 kN with foundation resting on a soil of SBC 120 kN/m<sup>2</sup>. Assume M20 concrete and Fe415 steel. (8 marks)
- (b) What are the objectives of earthquake-resistant design of reinforced concrete structures? What are the design requirements of beam-column joints in earthquake resistant design? (6 marks)
11. (a) Explain the different types of shallow footings.(2 marks)
- (b) Design an isolated rectangular footing for a column 450 mm x 600 mm to carry a load of 2400 kN. The SBC of the soil is 180 kN/m<sup>2</sup>. Use M20 concrete and Fe 415 grade steel. (10 marks)

\*\*\*\*\*

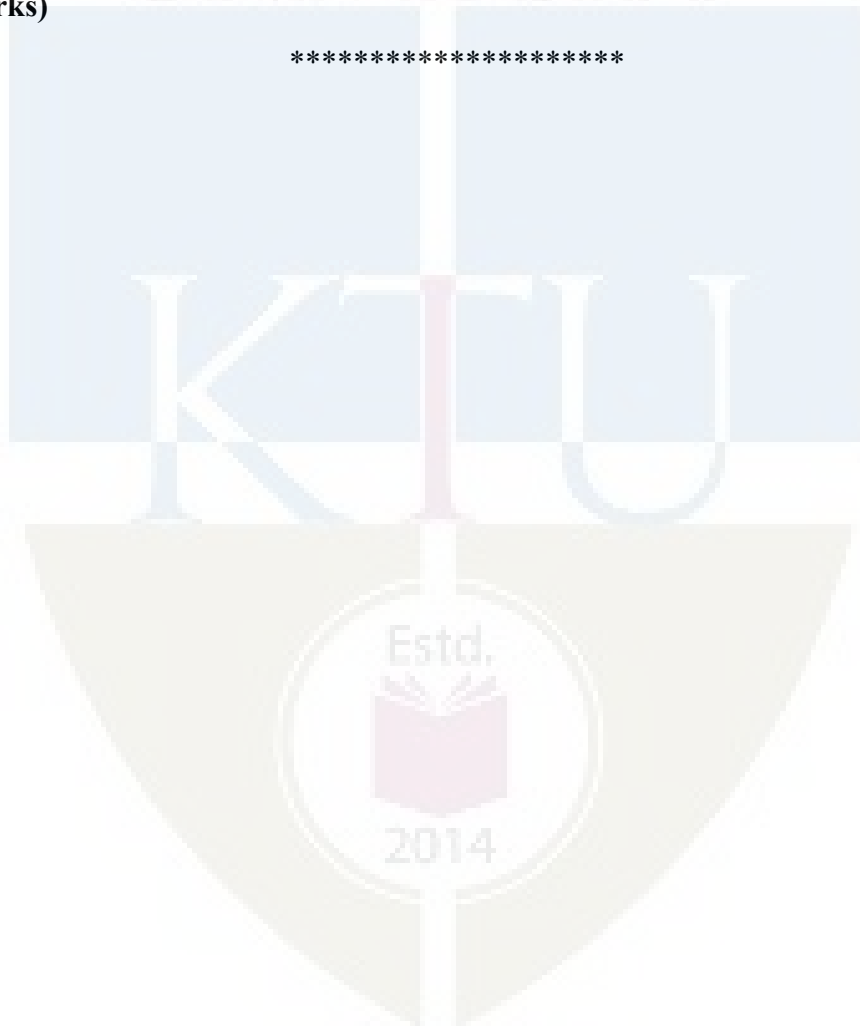

CET 305	GEOTECHNICAL ENGINEERING - II	CATEGORY	L	T	P	CREDIT	Year of Introduction
		PCC	4	0	0		4

**Preamble:** Goal of this course is to impart to the students, in-depth knowledge about the basic concepts and theories of foundation engineering. After this course, students will be able to recognize practical problems of foundations in real-world situations and respond accordingly.

**Prerequisite :** Geotechnical Engineering - I

**Course Outcomes:** After completion of the course the student will be able to:

CO 1	Understand soil exploration methods
CO 2	Explain the basic concepts, theories and methods of analysis in foundation engineering
CO 3	Calculate bearing capacity, pile capacity, foundation settlement and earth pressure
CO 4	Analyze shallow and deep foundations
CO 5	Solve the field problems related to geotechnical engineering

**Mapping of course outcomes with program outcomes (Minimum requirement)**

	PO 1	PO 2	PO 3	PO 4	PO 5	PO 6	PO 7	PO 8	PO 9	PO 10	PO 11	PO 12
CO 1	3	-	-	3	-	-	-	-	-	-	-	-
CO 2	3	-	-	-	-	-	-	-	-	-	-	-
CO 3	2	3	-	-	-	-	-	-	-	-	-	-
CO 4	2	2	3	-	-	-	-	-	-	-	-	-
CO 5	3	3	-	-	-	-	-	-	-	-	-	-

**Assessment Pattern**

Bloom's Category	Continuous Assessment Tests		End Semester Examination (Marks)
	Test 1 (Marks)	Test 2 (Marks)	
Remember	5	5	10
Understand	10	10	20
Apply	25	25	50
Analyse	10	10	20
Evaluate			
Create			

## Mark Distribution

Total Marks	CIE Marks	ESE Marks	ESE Duration
150	50	100	3 hours

## Continuous Internal Evaluation (CIE)Pattern :

Attendance	: 10 Marks
Continuous Assessment Test (2 numbers)	: 25 Marks
Assignment/Quiz/Course project	: 15 Marks

**End Semester Examination (ESE)Pattern** : There will be two parts; Part A and Part B. Part A contains 10 questions with 2 questions from each module, having 3 marks for each question. Students should answer all questions. Part B contains 2 questions from each module of which student should answer any one. Each question can have maximum 2 sub-divisions and carry 14 marks.

## Course Level Assessment Questions

*(Questions may be framed based on the outline given under each course outcome)*

Course Outcome 1 (CO1):

1. Understand Soil Investigation and Soil Exploration methods

Course Outcome 2 (CO2):

1. Explain the bearing capacity theory of shallow foundations
2. Explain the basic concepts and theory of settlement calculations of shallow foundations
3. Explain the concepts and theory of pile capacity
4. Explain the earth pressure theories for cohesionless and cohesive soils

Course Outcome 3 (CO3):

1. Calculate the bearing capacity of shallow foundations
2. Calculate pile capacity
3. Calculate the settlement of footings
4. Calculate the earth pressure acting on retaining walls

Course Outcome 4 (CO4):

1. Analyze and design shallow foundations
2. Analyze deep foundations

Course Outcome 5 (CO5):

1. Solve the field problems related to different types of shallow and deep foundations, retaining walls, etc.

## SYLLABUS

## CIVIL ENGINEERING

### Module 1

**Earth pressure** : Earth pressure - At rest, active and passive earth pressures - Practical examples Rankine's theory – Earth pressure and point of application for cohesionless and cohesive soils - Influence of surcharge and water table on earth pressure - Numerical problems - Earth pressure with layered backfill - Numerical problems - Coulomb's theory [no derivation required] – Comparison of Rankine's and Coulomb's theory

**Foundation – General Considerations** : Functions of foundations - definition of shallow and deep foundation - Selection of type of foundation - Different types of shallow foundations - advantages and limitations of various types of shallow foundations

### Module 2

**Bearing capacity of shallow foundations**: Gross and Net bearing pressure - Ultimate and Safe bearing capacity - Failure mechanism - Allowable soil pressure - Terzaghi's bearing capacity theory for strip footing [no derivation required] – Assumptions – Bearing capacity factors - Numerical problems - Terzaghi's formulae for circular and square footings - Numerical problems - Factors affecting bearing capacity - Effect of water table on bearing capacity - Numerical problems - General, local and punching shear failure - Skempton's formula – Numerical problems

### Module 3

**Settlement analysis**: Introduction- causes of settlement – estimation of immediate settlement – Numerical problems - Allowable settlement-Maximum and differential settlements as per Indian standard - Field test - Plate load test – Procedure, uses and limitations

**Footings** :Principles of design of footings – strip/continuous and individual footings - Numerical Problems - Combined footings- Rectangular and Trapezoidal combined footings - Numerical problems - Footings subjected to eccentric loading

**Raft foundations**: Types – Principles of design of raft foundation- Bearing capacity equations for raft on sand (Teng's equation based on SPT value) and for raft on clay (Skempton's formula) - Floating foundations - conventional design procedure for rigid mat.

### Module 4

**Pile foundations**: uses of piles - classification of piles - determination of type and length of piles - Bearing capacity of single pile in clay and sand [I.S. Static formulae] - Numerical problems - Dynamic formulae (Modified Hiley formulae only) – Numerical Problems - I.S. Pile load test [conventional] - Negative skin friction - Group action - Group efficiency - Capacity of Pile groups - Numerical problems

**Well foundation** : Elements of a well foundation – construction details of well foundations - Problems encountered in well sinking – Methods to rectify tilts and shifts

### Module 5

**Site investigation and soil exploration**: objectives - planning - reconnaissance - Guidelines for choosing spacing and depth of borings [I.S. guidelines only]- Methods of subsurface exploration - test pits - Auger borings – Wash Boring - Rotary drilling - Standard Penetration Test – procedure and correlations - Corrections for SPT value – Numerical Problems - Sampling - disturbed samples, undisturbed samples and chunk samples - types of samplers - Sampler parameters - Boring log - Soil

profile- Location of Water table - Geophysical methods : Seismic Refraction method and Electrical Resistivity method (in brief).

## CIVIL ENGINEERING

### **Text Books:**

1. Ranjan G. and A. S. R. Rao, Basic and Applied Soil Mechanics, New Age International, 2002.
2. Arora K. R., Geotechnical Engineering, Standard Publishers, 2006.

### **References:**

1. Das B. M., Principles of Geotechnical Engineering, Cengage India Pvt. Ltd., 2010.
2. Venkatramaiah, Geotechnical Engg, Universities Press, 2000.
3. Terzaghi K. and R. B. Peck, Soil Mechanics in Engineering Practice, John Wiley, 1967.
4. A V Narasimha Rao and C Venkatramaiah, Numerical Problems, Examples and Objective questions in Geotechnical Engineering, Universities Press (India) Ltd., 2000
5. Purushothamaraj P., Soil Mechanics and Foundation Engineering, Dorling Indersley(India) Pvt. Ltd., 2013
6. Taylor D.W., Fundamentals of Soil Mechanics, Asia Publishing House, 1948.

### **Course Contents and Lecture Schedule:**

Module	Contents	Outcomes Addressed	Hours
1	<b>Module 1</b>		<b>9</b>
1.1	<b>Earth pressure</b> : Earth pressure - At rest, active and passive earth pressures - Practical examples	CO 2 & CO 5	1
1.2	Rankine's theory – Earth pressure and point of application for cohesionless and cohesive soils	CO 2	1
1.3	Influence of surcharge and water table on earth pressure - Numerical problems	CO 2 & CO 3	2
1.4	Earth pressure with layered backfill - Numerical problems	CO 2 & CO 3	2
1.5	Coulomb's theory [no derivation required] – Comparison of Rankine's and Coulomb's theory	CO 2	1
1.6	<b>Foundation – General Considerations:</b> Functions of foundations - definition of shallow and deep foundation - Selection of type of foundation	CO 4 & CO 5	1
1.7	Different types of shallow foundations- advantages and limitations of various types of shallow foundations	CO 4 & CO 5	1
2	<b>Module 2</b>		<b>9</b>
2.1	<b>Bearing capacity of shallow foundations:</b> Gross and Net bearing pressure - Ultimate and Safe bearing capacity	CO 2	1
2.2	Failure mechanism - Allowable soil pressure	CO 2	1

2.3	Terzaghi's bearing capacity theory for strip footing [no derivation required] – Assumptions – Bearing capacity factors	CO 2	1
2.4	Numerical problems	CO 3	1
2.5	Terzaghi's formulae for circular and square footings - Numerical problems	CO 2 & CO 3	1
2.6	Factors affecting bearing capacity - Effect of water table on bearing capacity	CO 2	1
2.7	Numerical problems	CO 3	1
2.8	General, local and punching shear failure	CO 2 & CO 3	1
2.9	Skempton's formula – Numerical problems	CO 2 & CO 3	1
3	<b>Module 3</b>		<b>9</b>
3.1	<b>Settlement analysis:</b> Introduction- causes of settlement – estimation of immediate settlement – Numerical problems	CO 2 & CO 3	1
3.2	Allowable settlement-Maximum and differential settlements as per Indian standard	CO 2 & CO 5	1
3.3	Field test - Plate load test – Procedure, uses and limitations	CO 3 & CO 5	1
3.4	<b>Footings</b> :Principles of design of footings – strip/continuous and individual footings - Numerical Problems	CO 4	1
3.5	Combined footings- Rectangular and Trapezoidal combined footings	CO 4	1
3.6	Numerical problems	CO 4	1
3.7	Footings subjected to eccentric loading	CO 4	1
3.8	<b>Raft foundations:</b> Types – Principles of design of raft foundation- Bearing capacity equations for raft on sand (Teng's equation based on SPT value) and for raft on clay (Skempton's formula)	CO 3 & CO 4	1
3.9	Floating foundations - conventional design procedure for rigid mat.	CO 2 & CO 4	1
4	<b>Module 4</b>		<b>9</b>
4.1	<b>Pile foundations:</b> Uses of piles - classification of piles - determination of type and length of piles	CO 2 & CO 5	1
4.2	Bearing capacity of single pile in clay and sand [I.S. Static formulae]	CO 2	1
4.3	Numerical problems	CO 3	1
4.4	Dynamic formulae (Modified Hiley formulae only) – Numerical Problems	CO 2 & CO 3	1
4.5	I.S. Pile load test [conventional]	CO 5	1
4.6	Negative skin friction - Group action - Group efficiency	CO 2	1
4.7	Capacity of Pile groups - Numerical problems	CO 3 & CO 4	1
4.8	<b>Well foundation</b> : Elements of a well foundation – construction details of well foundations	CO 2 & CO 5	1



4.9	Problems encountered in well sinking – Methods to rectify tilts and shifts	CO 2 & CO 5	1
5	<b>Module 5</b>		<b>9</b>
5.1	<b>Site investigation and soil exploration:</b> objectives - planning - reconnaissance	CO 1	1
5.2	Guidelines for choosing spacing and depth of borings [I.S. guidelines only]	CO 1	1
5.3	methods of subsurface exploration - test pits - Auger borings – Wash Boring - Rotary drilling	CO 1	1
5.4	Standard Penetration Test – procedure and correlations	CO 1	1
5.5	Corrections for SPT value – Numerical Problems	CO 1	1
5.6	Sampling - disturbed samples, undisturbed samples and chunk samples	CO 1	1
5.7	types of samplers - Sampler parameters	CO 1	1
5.8	Boring log - soil profile- Location of Water table	CO 1	
5.9	Geophysical methods: Seismic Refraction method and Electrical Resistivity method (in brief).	CO 1	1

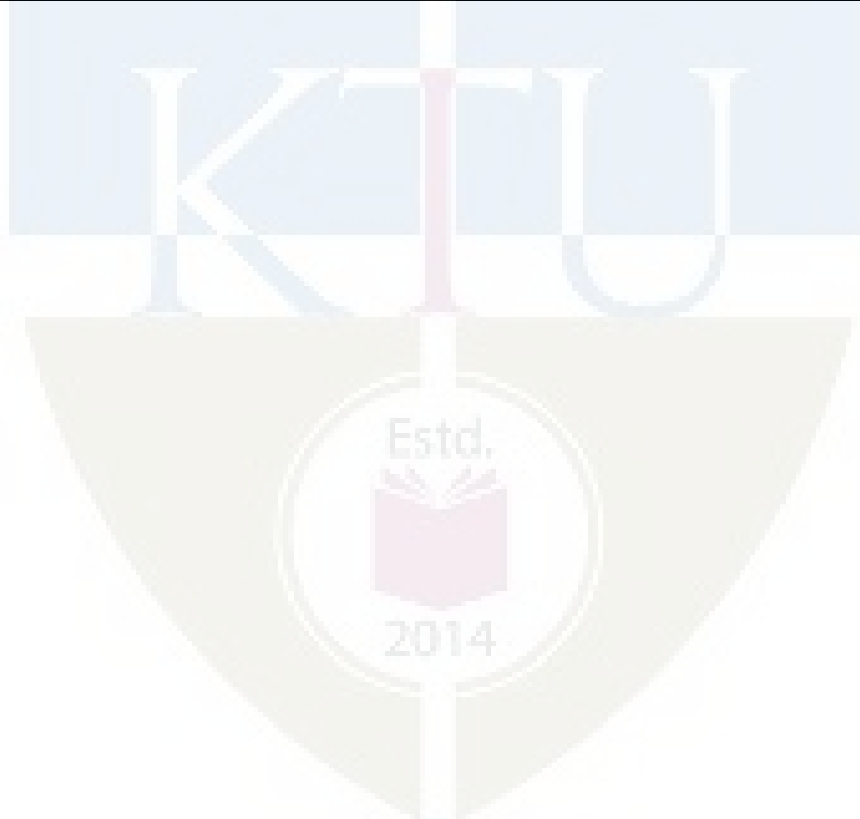

Reg No.: \_\_\_\_\_

Name: \_\_\_\_\_

**APJ ABDUL KALAM TECHNOLOGICAL UNIVERSITY**  
FIFTH SEMESTER B.TECH DEGREE EXAMINATION, MONTH & YEAR

**Course Code: CET305**

**Course Name : GEOTECHNICAL ENGINEERING - II**

Max. Marks: 100

Duration: 3 hours

**Part A**

*(Answer all questions; each question carries 3 marks)*

1. List the assumptions of Rankine's theory of earth pressure.
2. Explain the situations in which combined footings are provided.
3. Write the assumptions of Terzaghi's method for bearing capacity.
4. Explain the factors affecting bearing capacity.
5. Explain Allowable settlement.
6. Explain floating foundation.
7. Explain negative skin friction.
8. List the elements of a well foundation.
9. List Objectives of soil exploration.
10. Define (i) Inside clearance, (ii) Outside clearance and (iii) Area ratio as applied to sampler.

**PART B**

*(Answer one full question from each module, each question carries 14 marks)*

**Module – 1**

17. (a) Explain different types of earth pressures with practical examples. (6 Marks)  
(b) A wall of 8m height retains a non-cohesive layered backfill. Top 3 m soil is having  $\gamma = 18\text{kN/m}^3$  and  $\phi = 30^\circ$ . Bottom 5 m soil is having  $\gamma = 17.5\text{ kN/m}^3$  and  $\phi = 28^\circ$ . Using Rankine's theory, find the total active thrust on the wall and the point of application. (8 Marks)
18. (a) A 6m high retaining wall with vertical back supports soil which is in level with the top of retaining wall carries a uniform surcharge load of 20kPa. Backfill properties are  $c = 5\text{ kN/m}^2$ ,  $\gamma = 18.5\text{ kN/m}^3$ ,  $\phi = 30^\circ$ . Determine Rankine's passive earth pressure on the retaining wall. (6 Marks)  
(b) A 6m high retaining wall with vertical back supports soil which is in level with the top of retaining wall. Backfill properties are  $c = 5\text{ kN/m}^2$ ,  $\gamma = 18\text{ kN/m}^3$ ,  $\phi = 30^\circ$ . Find the maximum depth up to which excavation can safely be done without the sides caving in? Also determine Rankine's active earth pressure on the retaining wall before the formation of tension crack. (8 Marks)

**Module – 2**

11. (a) Differentiate between General shear failure and local shear failure. (6 Marks)
- (b) A strip footing of 2.0 m wide is to be founded at a depth of 1.6 m in a soil with following data:  
 $\gamma = 19 \text{ kN/m}^3$ ;  $c = 10 \text{ kN/m}^2$ ;  $\phi = 40^\circ$   
 $N_c = 95.7$ ;  $N_q = 81.3$ ;  $N_\gamma = 100.4$
- Determine the safe bearing capacity with a FS of 3, when
- Water table is at great depth
  - Water table is at a depth of 1.0 m from ground level.
  - Water table is at a depth of 3.0 m from ground level. (8 Marks)
12. (a) A Circular footing rests in pure clay with unconfined compressive strength  $q_u = 200 \text{ kN/m}^2$  at a depth of 1.5 m. Using Skempton's method, determine the diameter of footing if it has to transmit a net load of 1000 kN. Take FS = 3. (6 Marks)
- (b) A square footing 2m x 2m is at a depth of 1.5 m in a soil with  $c = 30 \text{ kN/m}^2$ ,  $\phi = 35^\circ$ , ( $N_c = 57.8$ ,  $N_q = 41.4$  and  $N_\gamma = 42.4$ ). Take  $\gamma = 18 \text{ kN/m}^3$ . Calculate the net safe load that can be carried by footing. (8 Marks)

**Module – 3**

13. (a) A rectangular surface footing 2m x 3m carries a column load of 600 kN. The footing rests on a  $c-\phi$  soil strata 6 m thick having  $\mu = 0.25$  and  $E$  as  $5000 \text{ kN/m}^2$ . Calculate the immediate settlement of footing assuming the influence factor  $I_f = 1.36$ . (6 Marks)
- (b) Explain Plate Load Test with neat sketch. List the limitations of plate load test. (8 Marks)
16. (a) What are the different types of raft foundations? Under what circumstances raft foundations are preferred? (6 Marks)
- (b) Design a rectangular combined footing for uniform pressure for the column loads of 1000 kN and 1500 kN at column A and B respectively. Projection of footing beyond centre line of column A is restricted to 0.5 m. Distance of c/c of columns is 5 m. Net Allowable pressure =  $150 \text{ kN/m}^2$ .
- Design a suitable combined footing if projection beyond centre line of both columns restricted to 0.5 m. (8 Marks)

**Module – 4**

19. (a) Explain the classification of pile foundations based on installation. (6 Marks)
- (b) A RCC pile weighs 25 kN is driven by drop hammer weighing 35 kN, having effective fall of 0.85 m. Average set/blow is 1.3 cm. Take elastic compression as 1.6 cm. Assuming coefficient of restitution as 0.25. Find ultimate and safe load on pile by assuming factor of safety of 2.5. (8 Marks)
20. (a) Explain any three methods (with neat sketches) for rectification of tilts in a well foundation. (6 Marks)
- (b) A bored pile in a clayey soil is 50 cm diameter and 10 m long, determine the capacity of a 3X3

pile group spaced 1 m centre to centre both ways. Take  $C_u = 70 \text{ kN/m}^2$  and  $\alpha = 0.6$ .

(8 Marks)

### Module – 5

14. (a) Explain Augur boring and wash boring methods used in soil exploration. (6 Marks)
- (b) Explain Standard Penetration Test? How this is correlated with shear strength parameters? What are the corrections to the observed SPT (N) value? (8 Marks)
15. (a) A SPT is conducted in a sand deposit at a depth of 16 m. Water table is at 7 m below ground level. Unit weight of sand is  $18 \text{ kN/m}^3$  above water table and  $19 \text{ kN/m}^3$  below water table. If N value is 36, find the corrected N value. (6 Marks)
- (b) Explain Geophysical Exploration using Seismic Refraction Method. What are its limitations? (8 Marks)

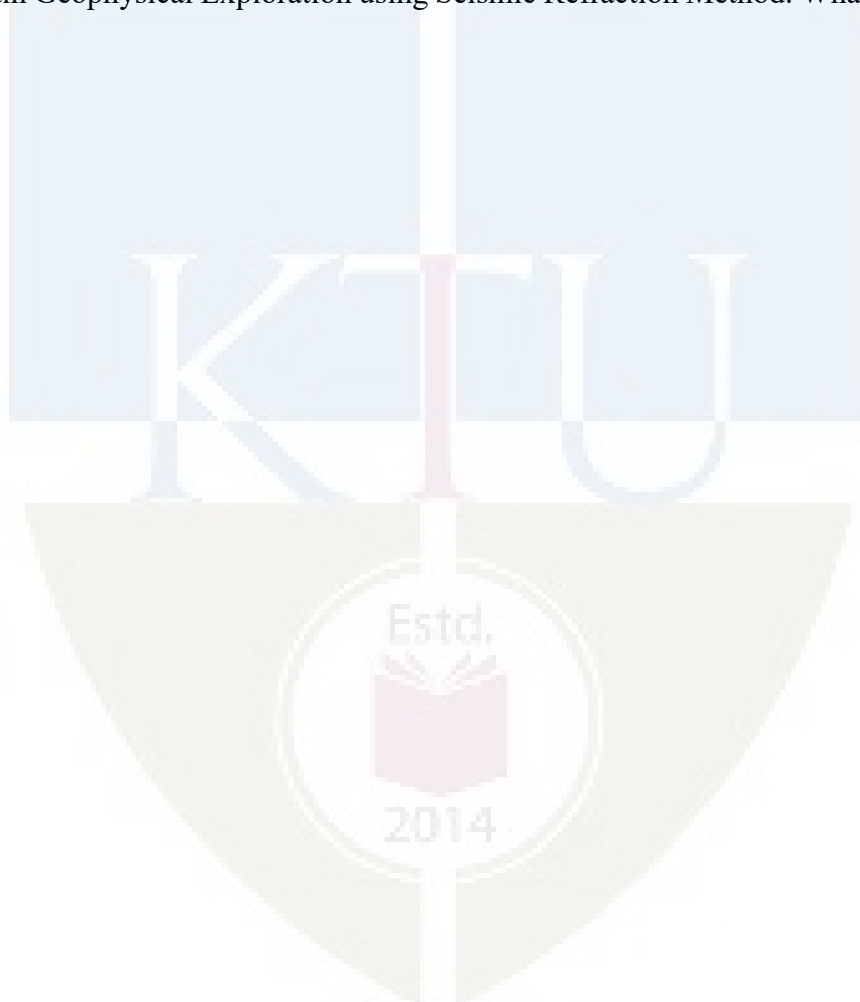

CET 307	HYDROLOGY & WATER RESOURCES ENGINEERING	Category	L	T	P	Credit	Year of Introduction
		PCC	4	0	0	4	2019

**Preamble:** The general objective of this course is to expose the students to the fundamental concepts of surface and groundwater components of hydrology and basics of water resources engineering. The course aim to impart the knowledge on the availability of water on hydrosphere, its distribution and quantification, scientific methods for computing irrigation water requirements, reservoir engineering and river engineering

**Pre-requisite:** NIL

**Course outcome**

After the course, the student will be able to:

CO1	Describe and estimate the different components of hydrologic cycle by processing hydro-meteorological data
CO2	Determine the crop water requirements for the design of irrigation canals by recollecting the principles of irrigation engineering
CO3	Perform the estimation of streamflow and/or describe the river behavior and control structures
CO4	Describe and apply the principles of reservoir engineering to estimate the capacity of reservoirs and their useful life
CO5	Demonstrate the principles of groundwater engineering and apply them for computing the yield of aquifers and wells

**CO - PO Mapping**

CET307 Hydrology and Water Resources		PO1	PO2	PO3	PO4	PO5	PO6	PO7	PO8	PO9	PO10	PO11	PO12
	CO1	3	3		1			1					
	CO2	3	3					1					
	CO3	3	2					1					
	CO4	3	3					1					
	CO5	3	3					1					

**Assessment pattern**

Bloom's Category	Continuous Assessment Tests		End Semester Examination (Marks)
	Test 1 (Marks)	Test 2 (Marks)	
Remember	5	5	15
Understand	10	10	15
Apply	20	20	40
Analyze	15	15	30
Evaluate			
Create			

**Continuous Internal Evaluation Pattern:**

Attendance	:	10 marks
Continuous Assessment Test (2 numbers)	:	25 marks
Assignment/Quiz/Course project	:	15 marks
<b>Total</b>	:	<b>50 marks</b>

**End semester examination pattern** – There will be two parts; Part A and Part B. Part A contain 10 questions with 2 questions from each module, having 3 marks for each question. Students should answer all questions. Part B contains 2 questions from each module of which student should answer any one. Each question can have maximum 2 sub-divisions and carry 14 marks.

**Course Code: CET 307**  
**Hydrology and Water Resources Engineering**  
**(Course Level Assessment Questions)**

CO1	Describe and estimate the different components of hydrologic cycle by processing hydro-meteorological data
1	Differentiate rainfall mass curve and hyetograph
2	Explain the use of double ring infiltration for infiltration measurement
3	Explain any three methods for baseflow separation
4	Explain the limitations of unit hydrograph theory
5	A storm with 10 cm of precipitation produced a direct runoff of 5.8 cm. The duration of the rainfall was 16 hrs and its time distribution is given below : (10 Marks)

	Time from start (h)	0	2	4	6	8	10	12	14	16				
	Cumulative rainfall (cm)	0	0.4	1.3	2.8	5.1	6.9	8.5	9.5	10				
Determine the $\phi$ -index of the storm.														
6	The ordinates of a 4-hour unit hydrograph for a particular basin are given below. Determine the ordinates of the 6-hour unit hydrograph.													
	Time (hrs)	0	2	4	6	8	10	12	14	16	18	20	22	24
	Discharge (Cumecs)	0	25	100	160	190	170	110	70	30	20	16	1.5	0

<b>CO2</b>	<b>Determine the crop water requirements for the design of irrigation canals by recollecting the principles of irrigation engineering</b>
1	Explain the factors affecting duty. Explain how can you improve the duty
2	Define duty and delta. Obtain the relation between the two
3	Define the different types of irrigation efficiencies
4	The following data pertaining to healthy growth of a crop: Root zone depth = 75 cm Field capacity = 27 %, Wilting point=14 % Dry density of soil=1500 kg/m <sup>3</sup> . Daily consumptive use =11 mm. Assuming 80 % depletion of available moisture as an indicator for application of water, determine how long the crop survive without irrigation
5	The CCA for a distributary is 15000 ha. The intensity of irrigation for Rabi is 40 % and for Kharif is 15 %. If the total water requirement of the two crops is 37.5 cm and 120 cm and their periods of growth are 160 days and 140 days respectively, determine the design discharge at the outlet.

<b>CO3</b>	<b>Perform the estimation of streamflow and/or describe the river behavior and control structures</b>												
1	Explain Meandering. What are the causes of meandering ?												
2	Explain the objectives of providing river training works												
3	Enlist the factors affecting the selection of site for stream gauging station												
4	The data pertaining to a stream gauging operation at a gauging station are given below. The rating equation of the current meter is $v = 0.32N_s + 0.032$ m/sec where $N_s$ is the number of revolutions per second. Compute the discharge in the stream by area velocity method												
	Distance from left water edge (m)	0	2	4	6	9	12	15	18	20	22	23	24
	Depth (m)	0	0.5	1.1	1.95	2.25	1.85	1.75	1.65	1.5	1.25	0.75	0
	Revolutions of current meter kept at 0.6 depth	0	80	83	131	139	121	114	109	92	85	70	0
	Duration of observation (s)	0	180	120	120	120	120	120	120	120	120	120	120
5	Describe with sketches different type of groynes												

<b>CO4</b>	<b>Describe and apply the principles of reservoir engineering to estimate the capacity of reservoirs and their useful life</b>												
1	Define safe yield, secondary yield and design yield of reservoirs												
2	Explain mass inflow curve and mass demand curve												
3	Explain with a neat sketch the zones of a storage reservoir												
4	Explain the procedure for estimating the life of storage reservoir												



5	The average annual discharge of a river for 11 years is given below											
	Year	1960	61	62	63	64	65	66	67	68	69	70
	Discharge (m <sup>3</sup> /sec)	1750	2650	3010	2240	2630	3200	1000	950	1200	4150	3500
Determine the storage capacity of a reservoir required to meet a demand of 2000 cumec throughout the year by mass curve method.												

<b>CO5</b>	<b>Demonstrate the principles of groundwater engineering and apply them for computing the yield of aquifers and wells</b>
1	State Darcy's law and its limitations
2	Enlist the assumptions in the derivation of Dupuit's equation
3	Differentiate perched aquifer and leaky aquifer
4	Describe the working of strainer type tube well with a sketch
5	Pumping at the rate of 1500 litres per minute from a 30cm diameter well of depth 60m in an unconfined aquifer gives a drawdown of 2m and 1.1m in observation wells located at distances 120m and 160m respectively from it. Calculate the drawdown of the pumping well and the coefficient of permeability of the aquifer.
6	During a recuperation test conducted on an open well in a region, the water level in the well was depressed by 3 m and it was observed to rise by 1.75 m in 75 minutes. (a) What is the specific yield of open wells in that region (b) What will be the yield from a well of 5 m diameter under a depression head of 2.5 m ? (c) What diameter should be the diameter of the well to give a yield of 12 l/sec under a depression head of 2 m ?

**Course Code: CET 307**  
**Hydrology and Water Resources Engineering**  
**Syllabus**

**Module I**

Hydrologic cycle-precipitation-mechanism, types, forms and measurement using rain gauges ; Optimum number of rain gauges, representation of rainfall data-mass curve and hyetograph, computation of mean precipitation over a catchment, Design rainfall - probable maximum rainfall; IDF curves (conceptual idea only). Infiltration-measurement by double ring infiltrometer, Horton's model, infiltration indices. Evaporation –measurement and control

**Module II**

Runoff-components of runoff- Hydrograph analysis-Hydrograph from isolated storm-Base flow separation. Unit hydrograph – uses, assumptions and limitations of unit hydrograph theory. Computation of storm/flood hydrograph of different duration by method of superposition and by development of S– Hydrograph; Floods-methods of design flood estimation –Empirical methods; SPF and PMF, Return period (conceptual ideas only)

**Module III**

Irrigation– Necessity, Benefits and ill effects. Types: flow and lift irrigation - perennial and inundation irrigation. Soil-water –plant relationships. Irrigation efficiencies, Computation of crop water requirement: depth and frequency of Irrigation. Duty and delta, duty-factors affecting and method of improving duty, Computation of crop water requirement by using the concept of duty and delta

**Module IV**

Streamflow measurement-area velocity method of stream gauging, selection of site for stream gauging station, Stage-discharge curve, flow duration curve-uses and characteristics. River training works-types; Meandering and meander parameters; Reservoirs- types, zones, yield of reservoir; determination of storage capacity and yield by mass curve method; Reservoir sedimentation and control- trap efficiency- computation of life of reservoir

**Module V**

Vertical distribution of ground water- classification of saturated formation (review) Aquifer properties, Darcy's law, Well hydraulics-Steady radial flow into a fully penetrating well in Confined and Unconfined aquifers; Types of wells, Types of tube wells; well losses; Yield of open wells-pumping test and recuperation test

**Text Books:**

1. Modi P. N. Irrigation, Water Resources and Water Power Engineering, S.B.H Publishers and Distributors New Delhi 2009.
2. Punmia B.C. Ashok K Jain, Arun K Jain, B. B. L Pande, Irrigation and Water Power Engineering, Laxmi Publications (P) Ltd. 2009

**References:**

3. VenTe Chow. Hand book of Applied Hydrology, Tata McGraw Hill, 1988
4. Todd D. K. Ground Water Hydrology, Wiley, 2005.
5. H.M Raghunath. Groundwater. New Age International New Delhi 2007
6. G.L.Asawa. Irrigation and Water Resources Engineering New Age International New Delhi 2008
7. Garg S. K. Hydrology and Water Resources Engineering, Khanna Publishers New Delhi 2005.
8. Garg SK, Irrigation Engineering and Hydraulic Structures Khanna Publishers New Delhi 2006.
9. Subramanya K. Engineering Hydrology, Tata McGraw Hill, 2013.
10. Raghunath H.M. Hydrology: Principles, Analysis and Design. New Age International New Delhi 2006.

**Course Code: CET 307**

**Hydrology and Water Resources Engineering  
(Course plan)**

Module	Topic	Course outcome addressed	No of Hours
<b>Module I (11 Hours)</b>			
1.1	Hydrology-Hydrologic cycle	CO1	1
1.2	Precipitation- mechanism, types, forms	CO1	1
1.3	Measurements of rainfall- Use of rain gauges	CO1	1
1.4	Representation of rainfall data-Rainfall Mass curve, hyetograph; Optimum number of rain gauges	CO1	1
1.5	Estimation of missing precipitation	CO1	1
1.6	Computation of mean precipitation	CO1	1
1.7, 1.8	Problems	CO1	2
1.9	Design rainfall - probable maximum rainfall; IDF curves	CO1	1

	(conceptual idea only).		
1.10	Water losses-Infiltration-measurement by double ring infiltrometer, Horton's equation; concept of infiltration indices	CO1	1
1.11	Evaporation-measurement by IMD land pan, control of evaporation	CO1	1
<b>Module II (9 Hours)</b>			
2.1	Runoff- Components, factors affecting runoff, Computation of runoff by different methods.	CO1	1
2.2	Runoff computation by rational formula and from infiltration indices	CO1	1
2.3	Hydrograph analysis-Hydrograph from isolated storm-Base flow separation	CO1	1
2.4	Concept of unit hydrograph-assumptions, uses, applications	CO1	1
2.5	Computation of storm/flood hydrograph ordinates of different duration by method of superposition	CO1	1
2.6	Computation of storm/flood hydrograph ordinates of different duration by development of S-Hydrograph	CO1	1
2.7,2.8	Problems	CO1	2
2.9	Floods-methods of design flood estimation –Empirical methods; SPF and PMF, Return period (conceptual ideas only)	CO1	1
<b>Module III (7 Hours)</b>			
3.1	Irrigation-Benefits and ill effects, lift and flow irrigation	CO2	1
3.2	Types of irrigation, Irrigation efficiencies	CO2	1
3.3	Soil water plant relationships	CO2	1
3.4	Computation of crop water requirement: depth and frequency of Irrigation	CO2	1
3.5	Duty and delta-Factors affecting and method of improving duty	CO2	1
3.6	Estimation of crop water requirement by using the concepts of duty and delta	CO2	1
3.7	Problems	CO2	1
<b>Module IV (11 Hours)</b>			
4.1	Streamflow measurement- measurement of stage and velocity	CO3	1
4.2	Stage-discharge curve- Selection of site for stream gauging station,	CO3	1
4.3	Computation of discharge (Area-velocity method)-problem	CO3	1
4.4	Flow duration curves-uses and characteristics	CO3	1
4.5	River behavior-meandering-meander parameters, Objectives of river training	CO3	1
4.6	Types of river training works	CO3	1

4.7	Reservoirs- types, zones, yield of reservoir	CO4	1
4.8	Storage capacity and yield-by mass curve method	CO4	1
4.9	Reservoir sedimentation-control of sedimentation, trap efficiency	CO4	1
4.10	Useful life of reservoir-computation.	CO4	1
4.11	Problems	CO4	1
<b>Module V (7 Hours)</b>			
5.1	Vertical distribution of ground water - classification of saturated formation (Review)	CO5	1
5.2	Aquifer properties- Darcy's law	CO5	1
5.3	Steady radial flow to a well-unconfined aquifers	CO5	1
5.4	Steady radial flow to a well-unconfined aquifers	CO5	1
5.5	Problems	CO5	1
5.6	Types of wells-open wells and tube well, Types of tube wells - description	CO5	1
5.7	Estimation of yield of an open well- pumping test and recuperation test	CO5	1

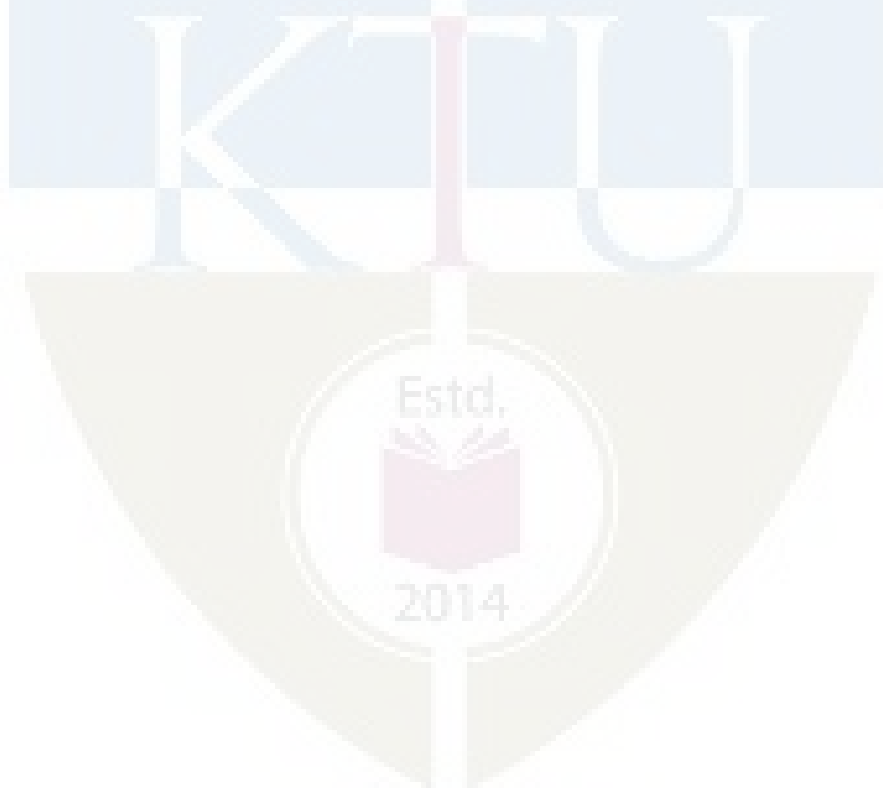

Pages: 3

Model Question Paper

Reg No.:.....

QP

CODE:.....

Name:.....

APJ ABDUL KALAM TECHNOLOGICAL UNIVERSITY  
FIFTH SEMESTER B.TECH DEGREE EXAMINATION, MONTH & YEAR

Course Code: CET 307

Hydrology and Water Resources Engineering

Max. Marks: 100  
hours

Duration: 3

Part A

(Answer all questions; each question carries 3 marks)

1. Explain the different forms of precipitation
2. What are the methods of control of evaporation from water bodies?
3. Define unit hydrograph. Explain its uses
4. State the limitations of rational formula for runoff estimation
5. Explain irrigation efficiencies
6. Define duty and delta. Obtain the relation between the two
7. Enlist the factors to be considered in the selection of site for a stream gauging station
8. Explain meandering of rivers
9. Define (i) Storativity (ii) Transmissibility
10. Explain well losses

Part B

(Answer one full question from each module, each question carries 14 marks)

Module I

- 11 (a) Explain the working of a Siphon type rain gauge with a neat sketch (5 Marks)

- (b) The average rainfall of 5 rain gauge stations in the base stations are 89, 54, 45, 41 and 55 cm. If the error in the estimation rainfall should not exceed 10 %, how many additional gauges may be required to be installed in the catchment? (9 Marks)

OR

- 12.(a) Compare different methods for determination of mean precipitation from a catchment (6 Marks)
- (b) Explain the use of double ring infiltrometer for the measurement of infiltration. How will you develop Horton's model? (8 Marks)

### Module II

- 13.(a) The rates of rainfall for the successive 30 min period of a 3-hour storm are:1.6, 3.6, 5.0, 2.8, 2.2, 1.0 cm/hr. The corresponding surface runoff is estimated to be 3.6 cm. Estimate the  $\phi$ -index (7 Marks)
- (b) Explain the characteristics of a single peak hydrograph from an isolated storm. How will you separate the base flow? (7 Marks)

OR

14. Find out the ordinates of a storm hydrograph resulting from a 9 hr storm with rainfall of 2, 5.75 and 2.75 cm during subsequent 3 hr intervals. The ordinates of 3hr unit hydrograph at 3 hr intervals are 0, 100, 355, 510, 380, 300, 260, 225,165, 120,85, 55,30, 22, 10, 0 (cumecs). Assume an initial loss of 0.5 cm and  $\phi$ -index of 2.5 mm/hr and abase flow of 10 cumecs. (14 Marks)

### Module III

15. (a) Differentiate lift irrigation and flow irrigation. (4 Marks)
- (b) Estimate the frequency of irrigation required for certain crop for the following data: Root zone depth = 90 cm Field capacity = 22 %, Wilting point=12 % Dry density of soil=1500 kg/m<sup>3</sup>. Daily Consumptive use =22 mm. Assume 70 % depletion of available moisture as an indicator for application of water (10 Marks)

OR

16. (a) Explain the benefits and ill effects of irrigation (4 Marks)

(b) What are the factors affecting duty? How can you improve the duty of water.

(10 Marks)

#### Module IV

17 (a) Explain the use of current meter for velocity measurement in streams (7 Marks)

(b) Explain the method of determination of useful life of a reservoir. (7 Marks)

OR

18 (a) Explain the features of different types of groynes (8 Marks)

(b) Explain the types of storage reservoirs (6 Marks)

#### Module V

19 (a) State Darcy's law and its limitations (4 Marks)

(b) The following observations were recorded during a pumping out test on a tube well penetrating fully in an aquifer: Well diameter: 25 cm, Discharge from the well: 300 m<sup>3</sup>/hr, RL of original water surface before pumping started: 122.000, RL of water in the well at constant pumping: 117.100, RL of water in the observation well: 121.300, RL of impervious layer: 92.000, radial distance of observation well from the tube well: 50 m. Determine : (a) field permeability coefficient of the aquifer (b) radius of zero drawdown.

(10 Marks)

OR

20.(a) Explain the method of determination of yield of an open well (7 Marks)

(b) Explain the working of a strainer type tube well with a sketch (7 Marks)



<b>CET309</b>	<b>CONSTRUCTION TECHNOLOGY AND MANAGEMENT</b>	<b>CATEGORY</b>	<b>L</b>	<b>T</b>	<b>P</b>	<b>CREDIT</b>	<b>Year of Introduction</b>
		<b>PCC</b>	<b>3</b>	<b>0</b>	<b>0</b>	<b>3</b>	<b>2019</b>

**Preamble:**

Construction Technology and Management introduces the basic concepts of civil engineering construction and its management. The course provides a detailed insight into the materials used in construction, various building elements and construction technology. Management is essential for successful completion of construction projects and the course introduces the students to the basic concepts of construction project management and planning. After the course, students will be familiar with the fundamental concepts of building construction and management.

**Prerequisite:** Basics of Civil and Mechanical Engineering

**Course Outcomes:** After completion of the course, the student will be able to

<b>Course Outcome</b>	<b>Description of Course Outcome</b>	<b>Prescribed learning level</b>
CO1	Describe the properties of materials used in construction	Understand
CO2	Explain the properties of concrete and its determination	Understand
CO3	Describe the various elements of building construction	Understand
CO4	Explain the technologies for construction	Understand
CO5	Describe the procedure for planning and executing public works	Understand
CO6	Apply scheduling techniques in project planning and control	Application

**Mapping of course outcomes with program outcomes(Minimum requirement)**

	<b>PO1</b>	<b>PO2</b>	<b>PO3</b>	<b>PO4</b>	<b>PO5</b>	<b>PO6</b>	<b>PO7</b>	<b>PO8</b>	<b>PO9</b>	<b>PO10</b>	<b>PO11</b>	<b>PO12</b>
<b>CO1</b>	3					1	1	1		1		1
<b>CO2</b>	3					1		1		1		1
<b>CO3</b>	3					1				1		1
<b>CO4</b>	3					2	1			1		1
<b>CO5</b>	3	2				1				1	3	1
<b>CO6</b>	3	3	3		1				2	1	3	1

**Assessment Pattern**

Bloom's Category	Continuous Assessment Tests		End Semester Examination
	1	2	
Remember	10	10	10
Understand	40	30	76
Apply		10	14
Analyse			
Evaluate			
Create			

**Mark distribution**

Total Marks	CIE (Marks)	ESE (Marks)	ESE Duration
150	50	100	3 hours

**Continuous Internal Evaluation Pattern:**

Attendance : 10 marks

Continuous Assessment Test (2 numbers) : 25 marks

Assignment/Quiz/Course project : 15 marks

**End Semester Examination Pattern:** There will be two parts; Part A and Part B. Part A contain 10 questions with 2 questions from each module, having 3 marks for each question. Students should answer all questions. Part B contains 2 questions from each module of which student should answer any one. Each question carries 14 marks and can have maximum 2 sub-divisions.

**Course Level Assessment (Sample) Questions****CO1: Describe the properties of materials used in construction**

1. Write a short note on manufacturing process of cement.
2. Explain any three laboratory tests on cement and its IS specifications.
3. Write a note on quality of water used for concrete.
4. Explain the various types of admixtures and their uses.

**CO2: Explain the properties of concrete and its determination**

1. Explain briefly the manufacturing process of concrete.
2. Explain a method to assess the workability of concrete. Also highlight the merits and demerits of the test.
3. Explain the factors affecting bleeding and segregation of concrete.
4. Explain the various factors affecting strength of concrete.

**CO3: Describe the various elements of building construction**

1. Discuss the purpose of providing damp proof course.
2. Distinguish between plastering and pointing.
3. Explain the various types of pointing with neat sketches.
4. State the advantages and disadvantages of framed structures.

**CO4: Explain the technologies for construction**

1. Explain voided slab construction.
2. Describe the classification of scaffolding.
3. Explain slipform construction.
4. Discuss the general reasons of building failure.

**CO5: Describe the procedure for planning and executing public works**

1. Differentiate between earnest money deposit and security deposit.
2. Discuss the advantages of a lump sum contract over an item-rate contract.
3. Explain the life cycle of a construction project.
4. Explain the process of tendering for a construction project.

**CO6: Apply scheduling techniques in project planning and control**

1. The following details regarding a project are given.

Activity	A	B	C	D	E	F	G	H	I	J
Immediate Predecessor	-	A	A	B	B	C	C	D	E, F	G
Duration (Days)	5	2	6	4	4	2	3	8	7	2

- (a) Prepare an Activity on Node Diagram.

- (b) Find the expected duration of the project.
- (c) Determine the critical activities.
- (d) Compute the total and free float of all the activities.

2. For the project details given below:

- (a) Draw the network.
- (b) Prepare the schedule of activities
- (c) What is the project completion time?
- (d) Which is the critical path?
- (e) Determine the probability of completing the project in 55 days?

Activity	A	B	C	D	E	F	G	H	I
Predecessor	-	A	A	B	B	C	E	D,F	G,H
a	4	5	4	15	10	8	4	1	6
m	6	7	8	20	18	9	8	2	7
b	8	15	12	25	26	16	12	3	8

## SYLLABUS

### Module 1

#### Construction Materials

Timber products –properties and uses of veneer, plywood, fibre board, particle board, multi wood

Cement: Manufacturing, chemical composition, Tests on cement – specific gravity, standard consistency, initial and final setting time, fineness, soundness, compressive strength, IS specifications

Aggregates – types, Gradation, importance of gradation, bulking of fine aggregate

Quality of water for construction (Brief discussion only, Permissible limits of chemical constituents not required)

Admixtures, uses – mineral admixtures – fly ash and ground granulated blast furnace slag and chemical admixtures – plasticizers, super plasticizers, accelerators, retarders (brief discussion only)

**Module 2****Concrete and Building Construction**

Process of manufacturing concrete – batching, mixing, transportation, placing, compacting, finishing, curing

Properties of fresh concrete: Workability, factors affecting workability, test on workability (slump test), segregation and bleeding (brief discussion)

Properties of hardened concrete: Strength, factors affecting strength, tests for strength of concrete in compression, tension and flexure

Lintels and arches: Types and construction details

Damp proof course (brief discussion only)

Finishing works: Plastering, pointing, painting – objectives and types

Structural systems – load bearing and framed construction, RCC and steel framed structures

**Module 3****Construction Technology**

Cost-effective construction – rapid wall construction, soil-cement block masonry, voided slab technology, filler slab technology (brief discussion only)

Scaffolding – uses and classification (brief discussion only)

Formwork – requirements of good formwork, classification, slipform (brief discussion only)

Prefabricated construction – advantages and disadvantages, prefabricated building components.

Basic concept of prestressing – fundamental understanding of pre-tensioned and post-tensioned construction

Construction 3D printing (brief discussion only)

Building failures – general reasons

Causes of failures in RCC, steel and masonry structures

**Module 4****Construction Project Management**

Construction projects, categories, life cycle of a project – pre-project phase, project phase, post-project phase, Detailed Project Report – contents

Tendering: types of tenders, stages in tendering

Contracts: types of contracts – item rate contract, lumpsum contract, percentage rate contract, turnkey contracts, concession contracts – BOT

## **Module 5**

### **Construction Planning**

Work break down structure

Types of Schedules – Construction schedule, Material schedule, labour schedule, equipment schedule, financial schedule

Bar chart, Mile Stone Charts

Networks, Network representation – Activity on Node (AoN) Diagram

Network analysis – Critical Path Method (CPM), Programme Evaluation and Review Technique (PERT) – concepts and problems

### **Text books:**

1. Shetty M.S. and A. K. Jain (2019), Concrete Technology: Theory and Practice, S. Chand & Company Pvt. Ltd.
2. Varghese P. C. (2007), Building Construction, Prentice Hall India.
3. Punmia B. C., Ashok Kumar Jain and Arun Kumar Jain (2016), Building Construction, Laxmi Publications (P) Ltd.
4. Sharma S.C. and S.V. Deodhar (2019), Construction Engineering & Management, Khanna Book Publishing Co. (P) Ltd.
5. Kumar Neeraj Jha (2015), Construction Project Management: Theory and Practice, Pearson India Education Services Pvt.Ltd.

### **Reference books:**

1. Sahu G. C. and Joygopal Jena (2015), Building Materials and Construction, McGraw Hill Education (India) Private Limited.
2. Gambhir M. L. (2004), Concrete Technology, Tata McGraw-Hill Publishing Company Limited.

3. Sharma S.K. (2019), Civil Engineering Construction Materials, Khanna Book Publishing Co. (P) Ltd.
4. Neville A.M. and Brooks J.J. (2010), Concrete Technology, Pearson Education Ltd.
5. Mehta P. K. and Paulo J. M. Monteiro (2014), Concrete-Microstructure, Properties and Materials, McGraw Hill Education.
6. Santhakumar R. (2006), Concrete Technology, Oxford Universities Press India.
7. Tony Bryan (2010), Construction Technology – Analysis and Choice, Wiley-Blackwell.
8. Joseph J. Moder, Cecil R. Philips and Edward W. Davis (1983), Project Management with CPM, PERT and Precedence Diagramming, Van Nostrand Reinhold Company Inc.
9. Charles Patrick (2012), Construction Project Planning and Scheduling, Dorling Kindersley India Pvt. Ltd.
10. Daniel W. Halpin and Bolivar A. Senior (2011), Construction Management, John Wiley and Sons Inc.

### Lecture Plan

Module	Topic	Course Outcomes addressed	No. of Lectures
1	<b>Module I (6 hours)</b>		
1.1	Timber products – properties and uses of veneer, plywood, fibre board, particle board, multi wood	CO1	1
1.2	Cement – Manufacturing, chemical composition	CO1	1
1.3	Tests on cement – specific gravity, standard consistency, initial and final setting time, fineness, soundness, compressive strength, IS specifications	CO1	1
1.4	Aggregates – types, Gradation, importance of gradation, bulking of fine aggregate	CO1	1
1.5	Quality of water for construction (Brief discussion only, Permissible limits of chemical constituents not required) Admixtures, uses – mineral admixtures – fly ash and	CO1	2

	ground granulated blast furnace slag and chemical admixtures – plasticizers, superplasticizers, accelerators, retarders (brief discussion only)		
2	<b>Module II (8 hours)</b>		
2.1	Concrete manufacturing – batching, mixing, transportation, placing, compacting, finishing, curing	CO2	2
2.2	Properties of fresh concrete: Workability, factors affecting workability, test on workability (slump test), segregation and bleeding (brief discussion)	CO2	1
2.3	Properties of hardened concrete: Strength, factors affecting strength, tests for strength of concrete in compression, tension and flexure	CO2	1
2.4	Lintels and arches: Types	CO3	1
2.5	Damp proof course (brief discussion only), Finishing works: Plastering, pointing (objectives and types)	CO3	1
2.6	Painting (objectives and types)	CO3	1
2.7	Structural systems – load bearing and framed construction, RCC and steel framed structures	CO3	1
3	<b>Module III (6 hours)</b>		
3.1	Cost-effective construction – rapid wall construction, soil-cement block masonry, voided slab technology, filler slab technology (brief discussion only)	CO4	1
3.2	Scaffolding – uses and classification (brief discussion only)	CO4	1
3.3	Formwork – requirements of good formwork, classification, slipform (brief discussion only)	CO4	1
3.4	Prefabricated construction – advantages and disadvantages, prefabricated building components. Basic concept of prestressing – fundamental understanding of pre-tensioned and post-tensioned	CO4	1



	construction Construction 3D printing (brief discussion only)		
3.5	Building failures – general reasons Causes of failures in RCC, steel and masonry structures	CO4	2
4	<b>Module IV (7 hours)</b>		
4.1	Introduction to construction project management, construction projects, categories	CO5	1
4.2	Life cycle of construction project – pre-project phase, project phase, post-project phase, Detailed Project Report – contents	CO5	2
4.3	Tendering, types of tenders, stages in tendering	CO5	2
4.4	Contracts – types of contracts – item rate contract, lumpsum contract, percentage rate contract, turnkey contracts, concession contracts – BOT	CO5	2
5	<b>Module V (8 hours)</b>		
5.1	Introduction to construction planning and scheduling, Work break down structure	CO6	1
5.2	Types of Schedules: Construction schedule, Material schedule, labour schedule, equipment schedule, financial schedule	CO6	1
5.3	Bar chart, Mile Stone Charts	CO6	1
5.4	Introduction of networks, Network representation – Activity on Node (AoN) Diagram, Critical Path Method (CPM) – concepts and problems on determination of critical path, floats	CO6	3
5.5	Programme Evaluation and Review Technique (PERT) – concepts and problems	CO6	2

**MODEL QUESTION PAPER**

Reg.No.: \_\_\_\_\_

Name: \_\_\_\_\_

**APJ ABDUL KALAM TECHNOLOGICAL UNIVERSITY****FIFTH SEMESTER B.TECH DEGREE EXAMINATION**

Course Code: CET309

Course Name: **CONSTRUCTION TECHNOLOGY AND MANAGEMENT**

Max. Marks: 100

Duration: 3 Hours

**PART A***Answer all questions. Each question carries 3 marks.*

1. Explain bulking of fine aggregate.
2. State the IS specification for initial and final setting time of OPC.
3. Discuss the various objectives of plastering.
4. List the various requirements of an ideal paint.
5. Briefly describe rapid wall construction technology.
6. Explain 3D printing in construction.
7. Discuss the advantages and disadvantages of an item-rate contract.
8. Explain selective tendering.
9. Explain the three time estimates in PERT.
10. Illustrate the use of a material schedule in organizing construction activities at a site.

(10×3 marks = 30 marks)

**PART B***Answer one full question from each module. Each full question carries 14 marks.***Module I**

11. a) Discuss the role of plasticizers in concrete. (6 marks)
- b) Differentiate between fibre board and particle board. (8 marks)

**OR**

12. a) Discuss the chemical composition of cement. (5 marks)
- b) Explain gradation of aggregates. Discuss the significance of gradation of aggregates. (9 marks)

**Module II**

13. a) Define workability of concrete. Explain the factors affecting workability. (5 marks)  
 b) Explain any three laboratory tests on hardened concrete. (9 marks)

**OR**

14. a) Explain various types of arches with neat sketches. (8 marks)  
 b) Distinguish between RCC framed and steel framed structures. (6 marks)

**Module III**

15. Explain the causes of failure in RCC structures. (14 marks)

**OR**

16. a) Discuss the advantages and disadvantages of prefabricated construction. (6 marks)  
 b) Explain filler slab technology. (8 marks)

**Module IV**

17. Discuss the details included in the DPR of an infrastructure project. (14 marks)

**OR**

18. Explain the project formulation stage of a construction project. (14 marks)

**Module V**

19. For the given data, draw an AON network and determine the critical path. Also find the total float, free float and independent float of each activity.

Activity	A	B	C	D	E	F	G	H	I
Predecessor	-	A	A	C	B	B, D	C	F, G	E, H
Duration (days)	4	6	4	2	4	5	3	4	2

(14 marks)

**OR**

20. The table shows the details of various activities of a small project.

Activity	A	B	C	D	E	F	G	H	I	J
Predecessor	-	-	A	A	B	E	C	D, F	H	G
Optimistic	4	3	7	5	6	2	3		2	6

time (days)										
Most likely time (days)	6	5	8	7	7	3	4	9	4	8
Pessimistic time (days)	8	7	9	9	8	4	5	11	6	10

- a) Draw an AON network and calculate the project completion time with 50% probability.
- b) Find the probability of completing the project in (i) 30 days; (ii) 26 days.
- c) What project completion date has 80% chance of being met? (14 marks)

\*\*\*\*\*

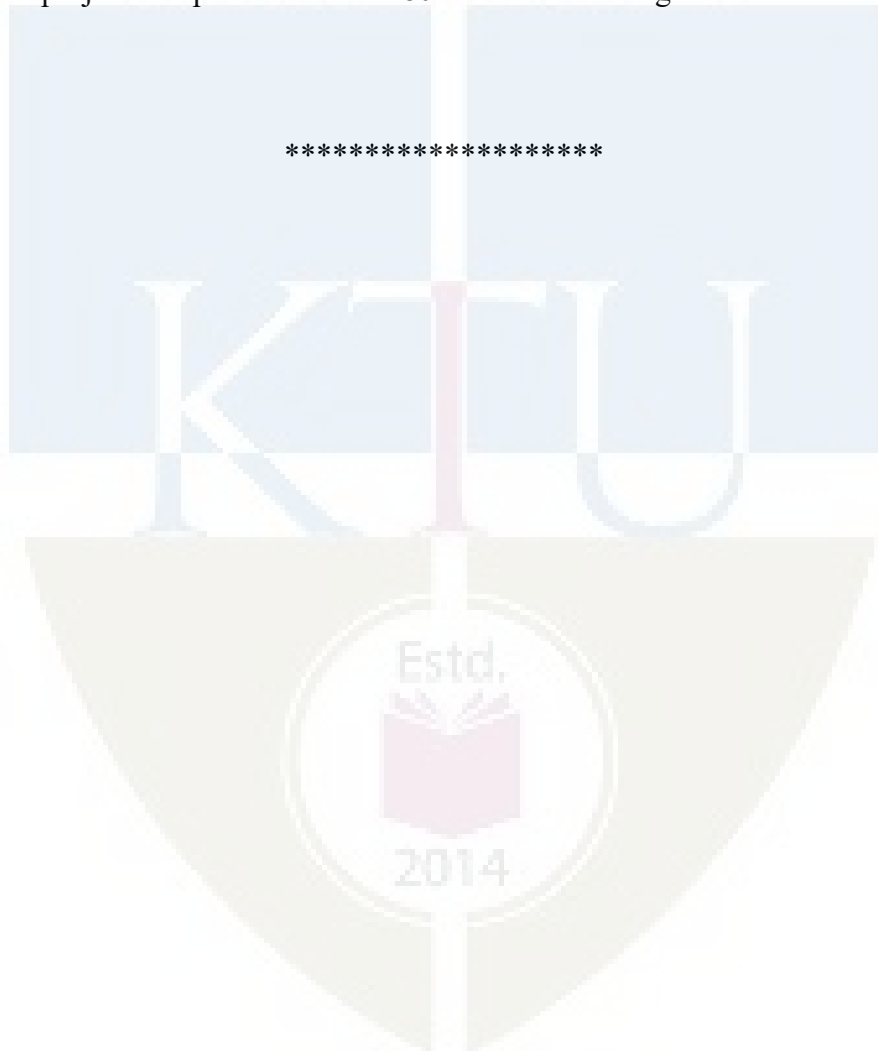

CEL331	MATERIAL TESTING LAB II	CATEGORY	L	T	P	CREDIT	YEAR OF INTRODUCTION
		PCC	0	0	3	3	2019

**Preamble:** The course aims to enrich the students to gain hands-on experience in conducting laboratory tests on various construction materials and thereby evaluate material quality and performance.

**Prerequisite:** Basics of Construction Engineering Materials.

**General Instructions to Faculty:**

- Any 12 of the 15 experiments included in the list of experiments need to be performed mandatorily. Virtual Lab facility cannot be used to substitute the conduct of these mandatory experiments.
- The laboratory should have possession of modern testing equipment such as Rebound hammer, ultrasonic pulse velocity, rebar locator, core cutter, concrete penetrometer and crack detection microscope at least for demonstration purposes.
- Periodic maintenance and calibration of various testing instruments needs to be made.
- Use of data visualization packages such as may be required for making various plots.

**Course Outcomes:** After the completion of the course, the student will be able to:

Course Outcome	Course Outcome Description
CO 1	To describe the basic properties of various construction materials
CO 2	Characterize the physical and mechanical properties of various construction materials.
CO3	Interpret the quality of various construction materials as per IS Codal provisions.

**Mapping of course outcomes with program outcomes:**

CO/PO	PO 1	PO 2	PO 3	PO 4	PO 5	PO 6	PO 7	PO 8	PO 9	PO 10	PO 11	PO 12
CO 1	3	2	2	2	1	3	-	-	2	2	-	2
CO 2	3	2	2	2	1	3	-	-	2	2	-	2
CO 3	3	2	2	2	1	3	-	-	2	2	-	2

**Assessment Pattern:**

**Mark distribution**

Total Marks	CIE	ESE	ESE Duration
150	75	75	2.5 hours

**Continuous Internal Evaluation Pattern:**

Attendance	:	15 marks
Continuous Assessment	:	30 marks
Internal Test (Immediately before the second series test)	:	30 marks

**End Semester Examination Pattern:** The following guidelines should be followed regarding award of marks

(a) Preliminary work	:	15 Marks
(b) Implementing the work/Conducting the experiment	:	10 Marks
(c) Performance, result and inference (usage of equipment and trouble shooting)	:	25 Marks
(d) Viva voce	:	20 marks
(e) Record	:	5 Marks

**General instructions:**

Practical examination to be conducted immediately after the second series test covering entire syllabus given below. Evaluation is a serious process that is to be conducted under the equal responsibility of both the internal and external examiners. The number of candidates evaluated per day should not exceed 20. Students shall be allowed for the University examination only on submitting the duly certified record. The external examiner shall endorse the record.

**References**

1. M.S.Shetty , Concrete Technology, Theory and Practice , S.Chand&Company, 2014  
A.M.Neville and J.J Brooks, Concrete Technology,Second edition, Pearson.
2. **IS codes on cement:**IS 1489(Part 1& 2):1991 Specification for Portland pozzolana cement,IS 269:1989 – Specification for ordinary Portland cement, 33 grade,IS 8112 : 2013- Specification for ordinary Portland cement, 43 grade, IS 12269 : 2013- Specification for ordinary Portland cement, 53 grade,
3. **IS codes on aggregate:**IS 2386(Part 1):1963 Methods of test for aggregates for concrete: Part 1 Particle size and shape, IS 2386(Part 3):1963 Methods of test for aggregates for concrete: Part 3 Specific gravity, density, voids, absorption and bulking, IS 383:1970Specification for Coarse and Fine aggregate from natural sources of concrete
4. **IS codes on fresh and hardened concrete:** IS 1199:1959 Methods of sampling and analysis of concrete, IS 10262:2019 Concrete mix proportioning- Guidelines, IS 516:1959 Methods of tests for strength of concrete.
5. **IS codes on brick and tiles:**IS 3495 (Part 1 to 4):1992 Methods of tests of burned clay bricks,IS 1077:1992 Common burned clay building bricks (specification),IS 654:1992 Clay roofing tiles Mangalore pattern (specification).
6. IS 13311 (Part 1 & 2):1992Non - destructive testing of concrete-methods of test.

**SYLLABUS**

- Exercise 1. Testing of Cement: Fineness, normal consistency, initial & final setting time.
- Exercise 2. Testing of Cement: Specific gravity and compressive strength
- Exercise 3. Study on soundness of cement.
- Exercise 4. Testing of Coarse and Fine Aggregate: Sieve analysis.
- Exercise 5. Testing of Coarse and Fine Aggregate: Water absorption, bulk density, void ratio, porosity and specific gravity.
- Exercise 6. Test on bulking of sand.
- Exercise 7. Test on coarse aggregate crushing value
- Exercise 8. Tests on fresh concrete :Measurement of workability of concrete by slump cone test and compacting factor test.
- Exercise 9. Study on workability of concrete by Vee-Bee test and flow test.
- Exercise 10. Concrete mix design by IS code method and casting of cubes, cylinders with designed concrete mixes.
- Exercise 11. Tests on hardened properties of concrete: Compressive, split and flexural strength.
- Exercise 12. Tests on hardened properties of concrete: Modulus of elasticity of concrete
- Exercise 13. Tests on brick, floor and roof tiles as per IS codal provision.
- Exercise 14. Study on Non-destructive tests on hardened concrete (Rebound hammer, ultrasonic pulse velocity and Rebar locator).
- Exercise 15. Study on concrete core cutter, concrete penetrometer and crack detection microscope.

CEL 333	GEOTECHNICAL ENGINEERING LAB	CATEGORY	L	T	P	CREDIT	YEAR OF INTRODUCTION
		PCC	0	0	3	2	2019

**Preamble:**

Objective of the course is to familiarize students with the laboratory tests used to determine physical, index and engineering properties of geomaterials.

**Prerequisite:** CET 204 GEOTECHNICAL ENGINEERING I

**Course Outcomes:** After the completion of the course, the student will be able to:

CO1	Identify and classify soil based on standard geotechnical experimental methods.
CO2	Perform and analyze permeability tests.
CO3	Interpret engineering behavior of soils based on test results.
CO4	Perform laboratory compaction, CBR and in-place density test for fill quality control in the field.
CO5	Evaluate the strength of soil by performing various tests viz. direct shear test, unconfined compressive strength test and triaxial shear test.
CO6	Evaluate settlement characteristics of soils.

Mapping of course outcomes (COs) with program outcomes (POs)

COs/POs	PO1	PO2	PO3	PO4	PO5	PO6	PO7	PO8	PO9	PO10	PO11	PO12
CO1	3				1				2	2		
CO2	3				2				2	2		
CO3	3	2							2	2		
CO4	3				1				2	2		
CO5	3				2				2	2		
CO6	3	1			2				2	2		

**Mark distribution**

Total Marks	Continuous Internal Evaluation (CIE)	End Semester Examination (ESE)	End Semester Examination (ESE) Duration
150	75	75	2.5 hours

**Continuous Internal Evaluation Pattern:**

Attendance : 15 marks

Continuous Assessment : 30 marks

Internal Test (Immediately before the second series test) : 30 marks



**End Semester Examination Pattern:** The following guidelines should be followed regarding award of marks.

- a) Preliminary work : 15 marks
- b) Implementing the work/ Conducting the experiment : 10 marks
- c) Performance, result and inference (usage of equipments and trouble shooting) : 25 marks
- d) Viva voce : 20 marks
- e) Record : 5 marks

**General instructions:**

Practical examination to be conducted immediately after the second series test covering entire syllabus given below. Evaluation is a serious process that is to be conducted under the equal responsibility of both the internal and external examiners. The number of candidates evaluated per day should not exceed 20. Students shall be allowed for the University examination only on submitting the duly certified record. The external examiner shall endorse the record.

**References**

1. IS codes relevant to each test
2. C. Venkatramiah, Geotechnical Engineering, New Age International publishers, 2012
3. Gopal Ranjan and A. S. R. Rao, Basic and Applied Soil Mechanics, New Age International Publishers, 2012
4. K. R. Arora, Soil Mechanics and Foundation Engineering, Standard Publishers, 2011

**SYLLABUS**

**Part A**

Estimation of physical and index properties of the given soil: After performing the set of experiments, students are expected to infer the results of the experiments in their engineering behavior.

1. Determination of Water Content and Specific Gravity
2. Sieve Analysis
3. Hydrometer/pipette Analysis
4. Atterberg Limits (Liquid Limit, Plastic Limit and Shrinkage Limit)
5. Swelling Test

## 6. Field Density determination

**Part B**

Determination of engineering properties of the given soil: Students should be familiarize with the tests to be performed to determine the engineering properties of the given soil and interpret the results for field application.

7. Permeability Test
8. Standard Proctor Compaction Test
9. Heavy compaction
10. California Bearing Ratio Test
11. Direct Shear test
12. Unconfined Compression Test
13. Consolidation Test

**Study/demonstration**

14. Triaxial test

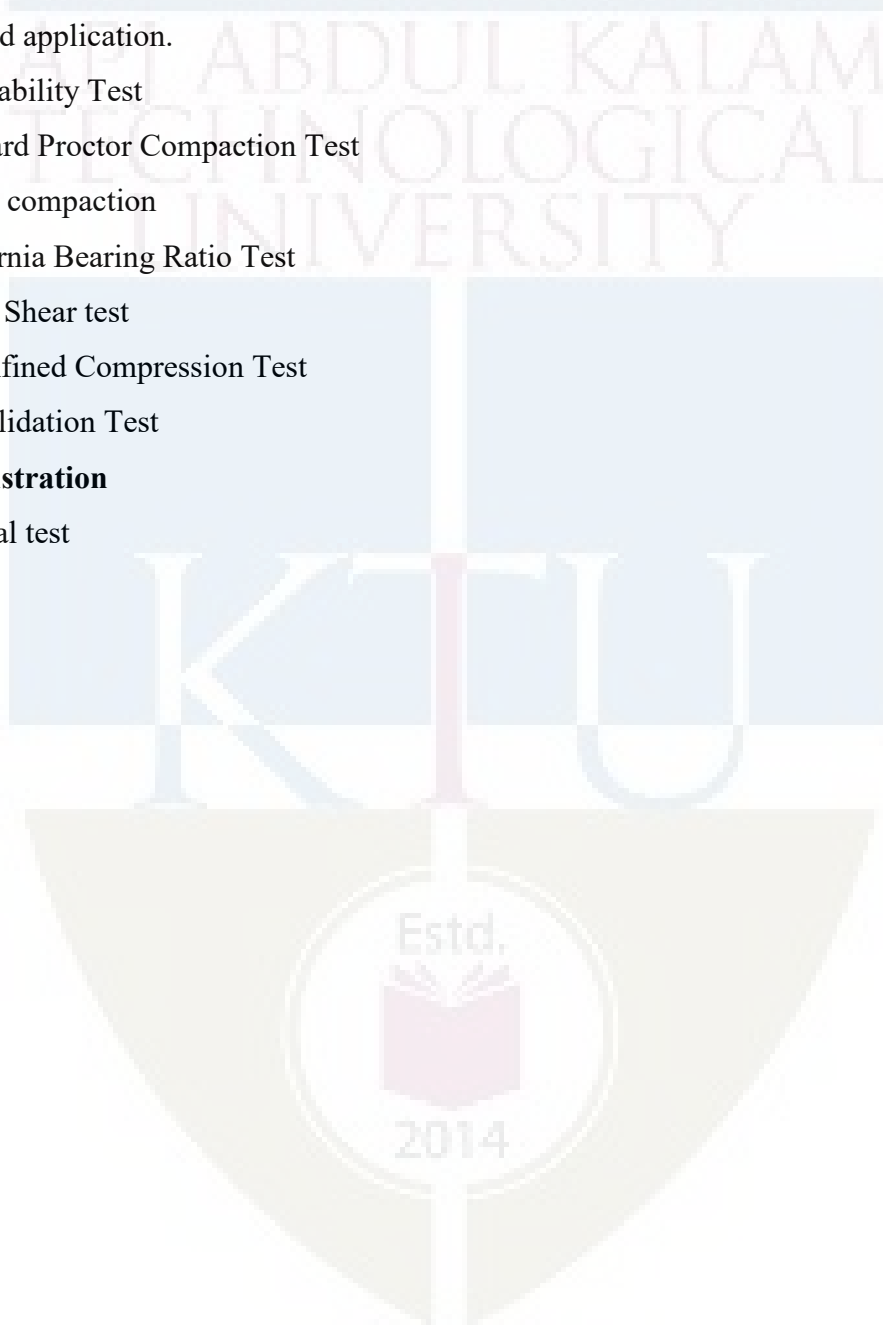

APJ ABDUL KALAM  
TECHNOLOGICAL  
UNIVERSITY

**SEMESTER V**

**MINOR**

KTU





**Assessment Pattern**

Bloom's Category	Continuous Assessment Tests		End Semester Examination
	1	2	
Remember/ Understand	20	20	30
Apply	30	30	70
Analyse			
Evaluate			
Create			

**Mark distribution**

Total Marks	CIE	ESE	ESE Duration
150	50	100	3 hours

**Continuous Internal Evaluation Pattern:**

Attendance	: 10 marks
Continuous Assessment Test (2 numbers)	: 25 marks
Assignment/Quiz/Course project	: 15 marks

**End Semester Examination Pattern:** There will be two parts; Part A and Part B. Part A contain 10 questions with 2 questions from each module, having 3 marks for each question. Students should answer all questions. Part B contains 2 questions from each module of which student should answer any one. Each question carries 14 marks and can have maximum 2 sub-divisions.

**Course Level Assessment (Sample) Questions**

**CO1: Recall the fundamental terms/theorems associated with mechanics of linear elastic deformable bodies and explain the behavior/response of various structural elements under various loading conditions.**

1. Explain Hooke's law.
2. Sketch the stress-strain curve of mild steel and mark the salient points
3. Explain the concept of BM and SF in beams, with the help of a cantilever beam subjected to uniformly distributed load over the whole span.
4. What is pure bending? Give an example.
5. What is point of contraflexure?
6. Explain (i) Section modulus and (ii) Moment of resistance

7. Distinguish between statically determinate and statically indeterminate structures.
8. What is degree of static indeterminacy? Explain with an example.
9. Explain (i) distribution factor and (ii) carry over moment.
10. Compare slope-deflection and moment distribution methods.

**CO2: Calculate the stresses/strains in structural elements subjected to axial load and bending/twisting moments.**

1. A 32 mm diameter steel bar is subjected to forces as shown in figure. Find the value of  $P$  necessary for equilibrium and stresses in different segments. Also calculate the final length of the bar. Take  $E = 200$  GPa.

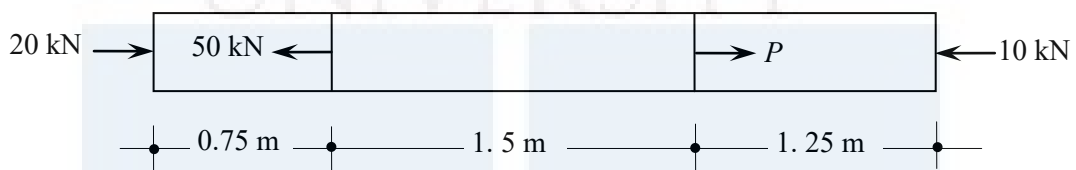

2. A strut and cable assembly ABC, shown in figure supports a vertical load  $P = 10$  kN. The cable has an effective cross sectional area of  $120 \text{ mm}^2$  and the strut has an area of  $200 \text{ mm}^2$ . Calculate the normal stresses induced in the cable and the strut and indicate whether they are tension or compression. If the cable elongates  $1.15$  mm and the strut shortens  $0.58$  mm find the strains also.

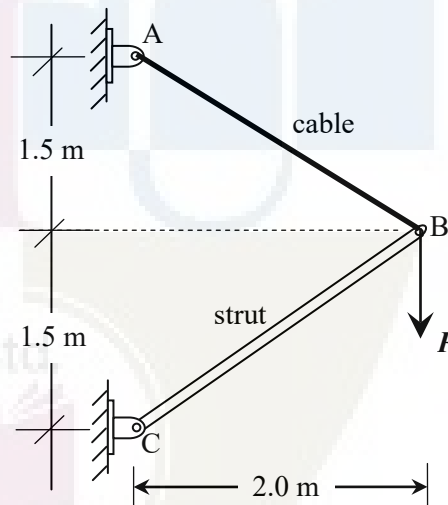

3. A tension test is carried out on a mild steel bar of 10 mm diameter. The bar yields under a load of 20 kN, it reaches a maximum load of 40 kN and breaks at 25 kN. The diameter of the bar at breaking was found to be 7 mm. The increase in length of the bar over a gauge length of 50 mm was found to be 0.029 mm under a load of 10 kN. Estimate (a) Young's modulus, (b) yield strength, (c) ultimate strength and (d) actual breaking strength.
4. A steel flat 25 mm wide and 6 mm thick is required to be bend into a circular arc of radius 10 m. Find the bending moment required to bend the flat. Also find the maximum stress induced. Take  $E = 200$  GPa.

5. A steel box section  $100 \text{ mm} \times 150 \text{ mm}$  with thickness  $5 \text{ mm}$  is used as a cantilever beam of span  $2 \text{ m}$ . If the beam carries a load of  $1 \text{ kN}$  at the free end, find the maximum bending stress at the mid span and the support. Neglect weight of the beam.
6. A timber beam  $150 \text{ mm} \times 200 \text{ mm}$  is used as a simply supported beam of span  $3 \text{ m}$ . Find the maximum load that can be applied at  $1 \text{ m}$  from one of the supports, if the maximum bending stress in the beam is not to exceed  $8 \text{ N/mm}^2$ . Neglect self weight of beam.
7. A beam of I section  $400 \text{ mm}$  deep has flanges  $200 \text{ mm}$  wide and  $20 \text{ mm}$  thick and web  $15 \text{ mm}$  thick. Compare its moment of resistance with that of a beam of rectangular section of the same weight, the depth being twice its breadth.
8. A solid circular shaft of diameter  $50 \text{ mm}$  is subjected to a torque. If the maximum shear stress induced in the shaft is  $70 \text{ MPa}$ , find the torque applied. If the modulus of rigidity of the material of the shaft is  $80 \text{ GPa}$ , find the angle of twist per meter length of the shaft.

**CO3: Analyse statically determinate beams and trusses to determine the internal forces.**

1. Draw the SFD and BMD of the beam shown.

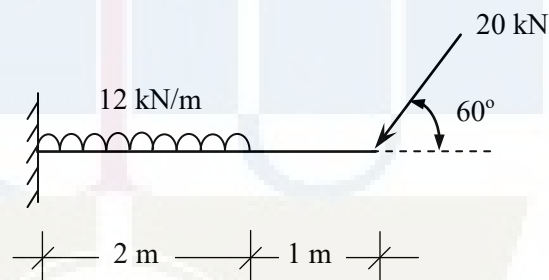

2. Draw SFD and BMD. Find the maximum BM also.

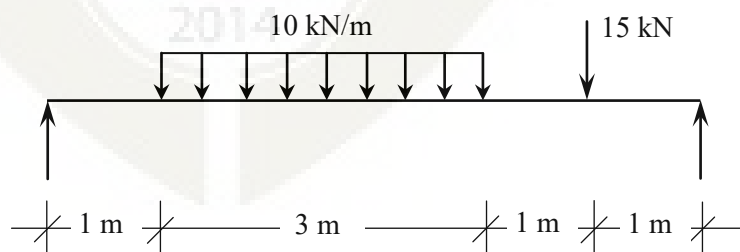

3. Analyse the truss by method of joints and determine the forces in all members.

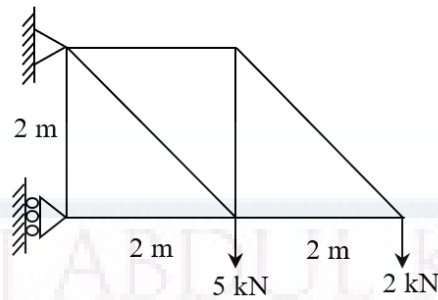

4. Analyse the truss by method of sections and determine the forces in members X, Y and Z.

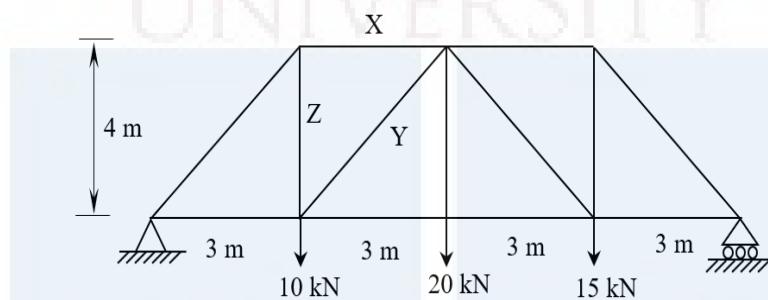

**CO4: Determine the deflection of statically determinate beams.**

1. A cantilever beam of span 3 m carries a point load of 10 kN at the free end along with a udl of 5 kN/m covering a distance of 2 m starting from the support. Find the maximum deflection of the beam. Take  $EI = 3500 \text{ kNm}^2$ .
2. Find the slope and deflection at the free end of the cantilever beam loaded as shown. Flexural rigidity ( $EI$ ) of the beam may be assumed to be constant.

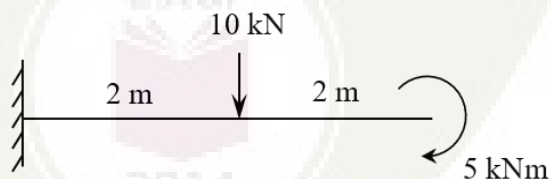

3. A simply supported beam of span 5 m carries a concentrated load of 20 kN at a distance of 2 m from the left support. Find the slope at supports and deflection under the load. Also find the maximum deflection and its location. Flexural rigidity of the beam is  $2200 \text{ kNm}^2$ .
4. A simply supported beam of span 4 m carries a udl of 10 kN/m covering half the span starting from the left support. Find the slope at supports and maximum deflection. Locate the point of maximum deflection also. Flexural rigidity of the beam is  $1500 \text{ kNm}^2$ .



**CO5: Analyse statically indeterminate beams and frames.**

1. Analyse the propped cantilever beam shown by consistent deformation method and draw BMD and SFD.

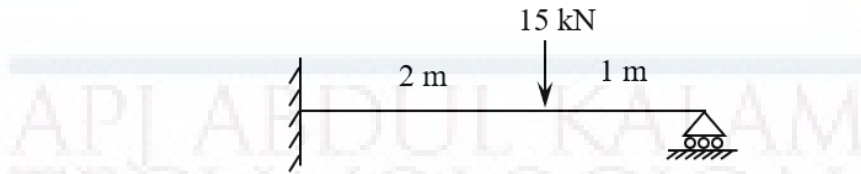

2. Analyse the continuous beam by slope deflection method and draw BMD.

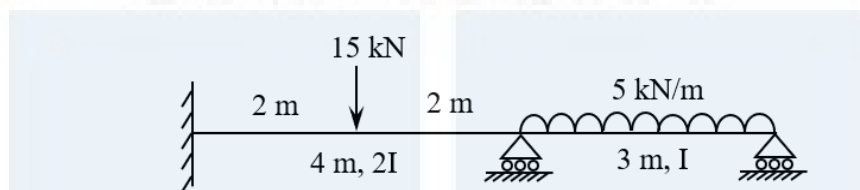

3. Analyse the frame by slope deflection method and draw BMD.

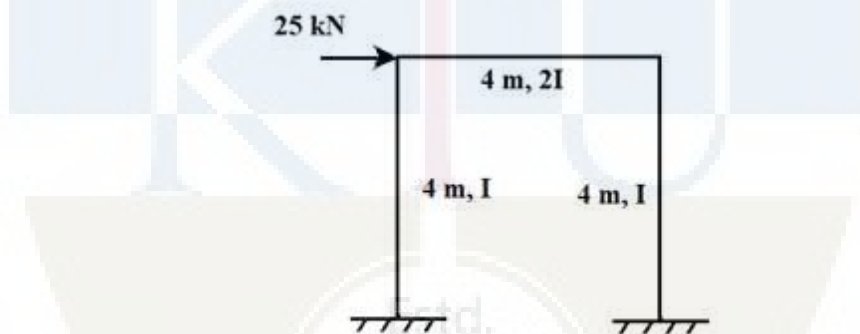

4. Analyse the frame shown in Question 2 using moment distribution method and draw BMD.
5. Analyse the continuous beam shown using moment distribution method and draw BMD.

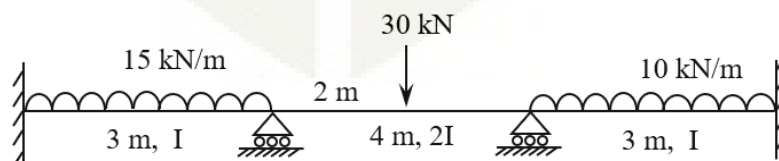

**SYLLABUS****Module – 1**

Review of statics, Concept of stress and strain – types, Stress – strain relation - Hooke's law, Young's modulus of elasticity.

Axially loaded bars with uniform cross section–stress, strain and deformation.

Deformation of axially loaded bars with varying cross section and bars with varying axial loads.

Torsion of circular shafts – stress and deformation, Power transmitted by circular shafts.

**Module – 2**

Analysis of truss – method of joints and method of sections.

Beams – different types. Types of loading on beams. Concept of bending moment and shear force.

Shear force and bending moment diagrams of cantilever beams and simply supported beams for different type of loads.

**Module – 3**

Theory of simple bending, assumptions and limitations.

Calculation of normal stress in beams, moment of resistance

Shear stress in beams (concept only).

Moment-curvature relation. Deflection of beams by successive integration.

Macaulay's method - Deflection of cantilever beams and simply supported beams.

**Module – 4**

Statically indeterminate structures, degree of static and kinematic indeterminacy.

Fixed beam – fixed end moments for simple cases of loading (No analysis required).

Method of consistent deformation - Analysis of propped cantilever beam and continuous beams with maximum two redundants.

**Module – 5**

Slope deflection method – Analysis of continuous beams with maximum two unknowns, effect of support settlement. Analysis of frames with sway.

Moment distribution method – analysis of continuous beams and frames without sway.

**Text Books:**

1. Egor P. Popov, Engineering Mechanics of Solids, Prentice Hall International Series.
2. James M Gere, S.P. Timoshenko, Mechanics of Materials, CBS Publishers and Distributors, New Delhi.

- R. K. Bansal, A Text book of Strength of Materials, Laxmi Publications (P) Ltd, New Delhi.

### References:

- R.C. Hibbeler, Structural Analysis, Pearson.
- Devdas Menon, Structural Analysis, Narosa Publications.
- H. J. Shah and S. B. Junnarkar, Mechanics of Structures Vol - I, Charotar Publishing House.
- S. Ramamrutham and R. Narayanan, Strength of Materials, Dhanpat Rai Publishing Co (P) Ltd.
- B. C. Punmia, Ashok K. Jain, Arun Kumar Jain, Mechanics of Materials, Laxmi Publications (P) Ltd, New Delhi.

### Lecture Plan – Structural Mechanics

Module	Topic	Course Outcomes addressed	No. of Lectures
<b>1</b>	<b>Module I: Total lecture hours: 9</b>		
1.1	Review of statics – equilibrium conditions, free body diagrams, centroid, moment of inertia.	-	1
1.2	Concept of stress, types of stresses. Concept of strain, types of strains. Stress – strain relation - Hooke's law, Young's modulus of elasticity. Stress-strain ( $\sigma - \epsilon$ ) diagram of mild steel.	CO1	1
1.3	Axially loaded bars with uniform cross section – calculation of stress, strain and deformation.	CO1, CO2	1
1.4	Deformation of axially loaded bars with varying cross section. Stepped bars, deformation of axially loaded bars with varying axial loads	CO1, CO2	3
1.5	Torsion of circular shafts, assumptions, derivation of torsion equation. Variation of stress across the cross section. Polar modulus.	CO1	1
1.6	Calculation stress and deformation of circular shafts subjected to torsion. Power transmitted by circular shafts.	CO1, CO2	2
<b>2</b>	<b>Module II: Total lecture hours:10</b>		
2.1	Analysis of truss – Method of joints	CO1, CO3	2

2.2	Analysis of Truss – Method of sections	CO1, CO3	2
2.3	Beams – different types. Types of loading on beams. Concept of bending moment and shear force. Shear force and bending moment diagrams.	CO1, CO3	2
2.4	Shear force and bending moment diagrams of cantilever beams subjected to point load, uniformly distributed load, uniformly varying load and concentrated moment.	CO3	2
2.5	Shear force and bending moment diagrams of simply supported beams subjected to point load and uniformly distributed load.	CO3	2
<b>3</b>	<b>Module III : Total lecture hours : 9</b>		
3.1	Theory of simple bending – derivation of equation, assumptions and limitations.	CO1, CO2	1
3.2	Calculation of normal stress in beams, moment of resistance. Problems involving bending stress. Shear stress in beams (concept only)- variation of shear stress across the cross section.	CO1, CO2	2
3.3	Moment-curvature relation. Basic differential equation for calculating the deflection of beams. Calculation of deflection by successive integration. Principle of superposition.	CO1, CO4	2
3.4	Macaulay's method - Deflection of cantilever beam subjected to point load and uniformly distributed loads.	CO1, CO4	2
3.5	Macaulay's method - Deflection of simply supported beams subjected to point load and uniformly distributed loads. Clerk Maxwell's theorem of reciprocal deflection	CO1, CO4	2
<b>4</b>	<b>Module IV: Total lecture hours:8</b>		
4.1	Statically indeterminate structures, degree of static and kinematic indeterminacy - examples Force and displacement method of analysis (concept only)	CO1	1
4.2	Fixed beam – fixed end moments for simple cases of loading (No analysis required). BMD of fixed beam, point of contraflexure.	CO1, CO3	2
4.3	Method of consistent deformation - Analysis of propped cantilever beam.	CO1, CO5	2

4.4	Method of consistent deformation – analysis of beams with maximum two redundants.	CO1, CO5	3
<b>5</b>	<b>Module V: Total lecture hours:9</b>		
5.1	Slope deflection method – equation (no derivation required). Analysis of continuous beams with maximum two unknowns.	CO1, CO5	2
5.2	Slope deflection method – analysis of continuous beam with support settlement.	CO1, CO5	1
5.3	Slope deflection method – analysis of frames with sway.	CO1, CO5	2
5.4	Moment distribution method – concept. Distribution factor and carry over moment.	CO1, CO5	1
5.5	Moment distribution method – analysis of continuous beams.	CO1, CO5	1
5.6	Moment distribution method – analysis of frames without sway.	CO1, CO5	2

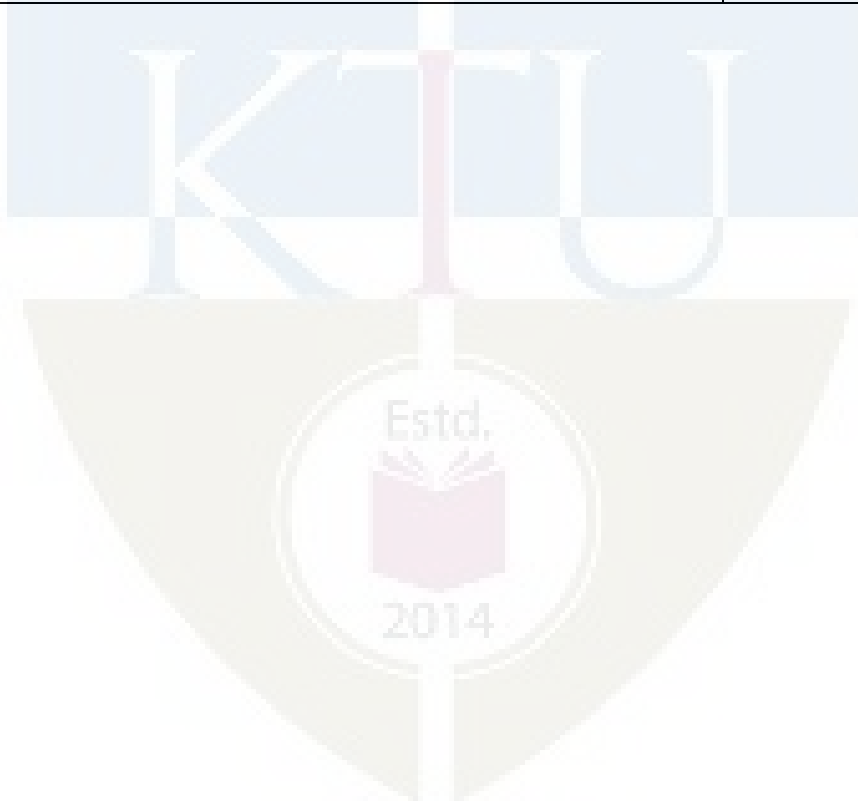

**MODEL QUESTION PAPER**

Reg. No.: \_\_\_\_\_

Name: \_\_\_\_\_

**APJ ABDUL KALAM TECHNOLOGICAL UNIVERSITY**  
**FIFTH SEMESTER BTECH DEGREE EXAMINATION**

**Course Code: CET381**

**Course Name: STRUCTURAL MECHANICS**

Max. Marks: 100

Duration: 3 Hours

**PART A**

*Answer all questions; each question carries 3 marks.*

1. a) Sketch the stress-strain graph of mild steel and mark the salient points.
- b) A steel bar of length 1 m and diameter 12 mm was found to elongate by 0.64 mm under an axial load of 15 kN. Find the stress induced and modulus of elasticity of the material.
- c) What is the advantage of method of sections over method of joints in the analysis of trusses?
- d) What is the relationship between SF and BM? Illustrate with a simple example.
- e) What is pure bending? Give an example.
- f) Using successive integration method, find the deflection at the free end of a cantilever beam carrying a point load at the free end.
- g) Explain 'static indeterminacy' and 'kinematic indeterminacy' with a suitable example.
- h) Write down the consistent deformation equations for a beam with degree of static indeterminacy =2. Explain the basic terms in the equation.
- i) What are the reasons for side sway in frames?
- j) Write notes on (i) distribution factor and (ii) carry over moment.

(10×3 marks = 30 marks)

**PART B**

*Answer one full question from each module; each full question carries 14 marks.*

**Module I**

2. A 32 mm diameter steel bar is subjected to forces as shown in figure. Find the value of  $P$  necessary for equilibrium and stresses in different segments. Also calculate the final length of the bar. Take  $E = 200$  GPa.

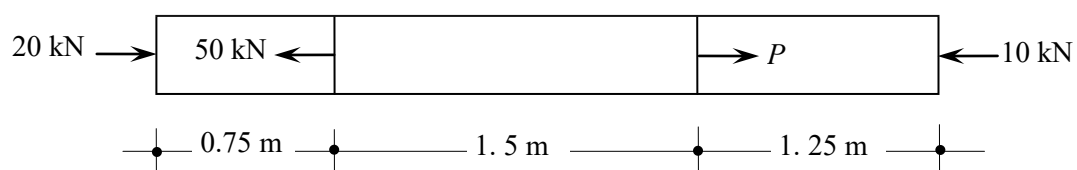

3. A tension test is carried out on a mild steel bar of 10 mm diameter. The bar yields under a load of 20 kN, it reaches a maximum load of 40 kN and breaks at 25 kN. The diameter of the bar at breaking was found to be 7 mm. The increase in length of the bar over a gauge length of 50 mm was found to be 0.029 mm under a load of 10 kN. Estimate (a) Young's modulus, (b) yield strength, (c) ultimate strength and (d) actual breaking strength.

### Module II

4. Draw the SFD and BMD of the beam loaded as shown in figure. Find the maximum BM and locate the point of maximum BM also.

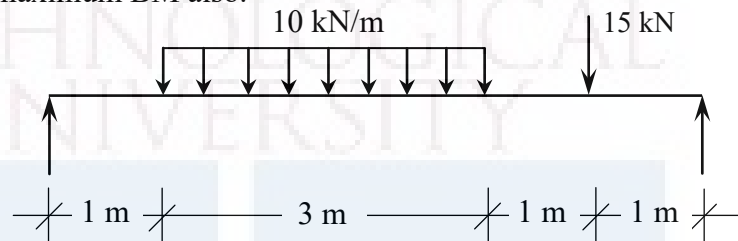

5. Analyse the truss by method of joints and determine the forces in all members.

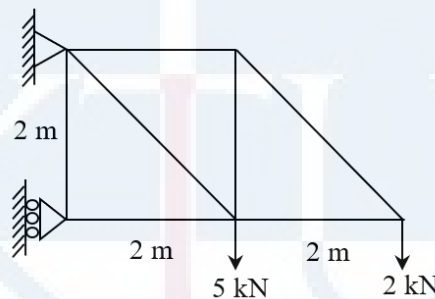

### Module III

6. A beam of I section 400 mm deep has flanges 200 mm wide and 20 mm thick and web 15 mm thick. Compare its moment of resistance with that of a beam of rectangular section of the same weight, the depth being twice its breadth.
7. A simply supported beam of span 4 m carries a udl of 10 kN/m covering half the span starting from the left support. Find the slope at supports and maximum deflection. Locate the point of maximum deflection also. Flexural rigidity of the beam is  $1500 \text{ kNm}^2$ .

### Module IV

8. a) Draw the BMD of a fixed beam carrying udl through out its span. (4 marks)
- b) Analyse the propped cantilever beam shown by consistent deformation method and draw BMD and SFD.

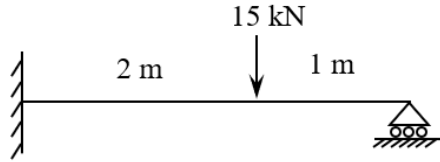

(10 marks)

9. Analyse the beam shown by consistent deformation method and draw BMD.

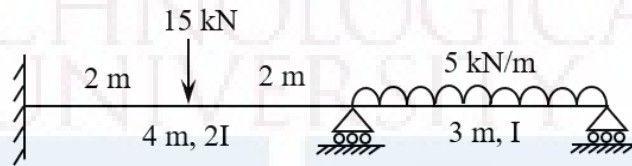

**Module V**

10. Analyse the frame by slope deflection method and draw BMD.

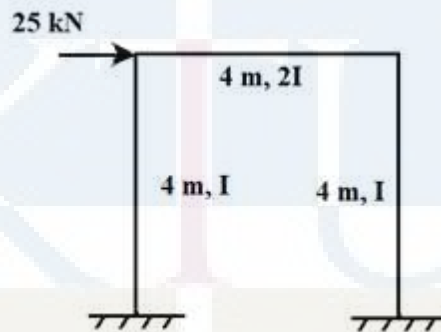

11. Analyse the continuous beam shown using moment distribution method and draw BMD.

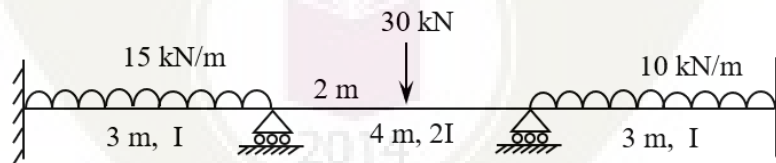

\*\*\*\*\*



CET383	ECO-FRIENDLY TRANSPORTATION SYSTEMS	CATEGORY	L	T	P	CREDIT	YEAR OF INTRODUCTION
		VAC	3	1	0	4	2019

**Preamble :** Objective of the course is to introduce the principles and practice of sustainability on transportation systems and development of an eco-friendly transport system.

**Prerequisite:** Nil

**Course Outcomes:**

	Description
CO No.	At the end of the course, students will be able to:
CO 1	Apply the basic principles of sustainability to infrastructure related problems
CO 2	Analyse Transportation network for eco-friendliness and quantify the levels.
CO 3	Design eco-friendly transportation systems
CO 4	Apply concepts of sustainability in developing green fuels and vehicles.
CO 5	Design for sustainability in public transport, Applications of tools like GIS, GPS.

**Mapping of course outcomes with program outcomes**

	PO1	PO2	PO3	PO4	PO5	PO6	PO7	PO8	PO9	PO10	PO11	PO12	PSO1	PSO2
CO 1	2	2	2	1		1	3	1		2		1	2	3
CO 2	2	2	1	2	1	1	1	1	1	1		1	2	2
CO 3	2	1	3	1	2	1	1	1	2	2	1	2	2	3
CO 4	2	2	2	1	1	2	2	1	1	1	1	2	2	3
CO 5	1	3	3	3	3	3	2	2	3	3	2	2	2	3

**Assessment Pattern**

Bloom's Category	Continuous Assessment		End Semester Examination (marks)
	Test 1 Marks	Test 2 Marks	
Remember	7.5	7.5	30
Understand	7.5	7.5	30
Apply	-	-	-
Analyse	5	5	20
Evaluate	5	5	20
Create			

**Mark Distribution**

Total Marks	CIE (Marks)	ESE (Marks)	ESE Duration
150	50	100	3 hours

**Continuous Internal Evaluation Pattern:**

Attendance	: 10 marks
Continuous Assessment Test (2 numbers)	: 25 marks
Assignment/Quiz/Course Project	: 15 marks

**End Semester Examination Pattern:**

The question consists of two parts- Part A and Part B. Part A consists of 10 questions with 3 marks for each (two questions from each module). Part B consists of two questions from each module, out of which one has to be answered. Each question carries 14 marks and can have maximum 2 subdivisions.

**Sample Course Level Assessment Questions:**

- 1 Course Outcome 1 (CO1):** Define sustainability in transportation context. How can the principles be applied here?
- 2 Course Outcome 2 (CO2):** Describe the procedure of evaluating the performance of a transportation network, citing any example.
- 3 Course Outcome 3 (CO3):** What are the characteristics of eco-friendly transportation system? What changes are to be incorporated in designing the same?
- 4 Course Outcome 4 (CO4):** Discuss the concept of green vehicles describing the aspects that make them green.

**5 Course Outcome 5 (CO5):** Giving KSRTC as an example explain how sustainability can be achieved in public transport.

### Syllabus

Module	Contents	Hours
1	Introduction to the concept of sustainability, basic principles.	10
2	Transport networks basics, Performance measures, Advanced transport systems	10
3	Design for eco-friendly Transportation, Professional praxis in sustainability, concept and applications	9
4	Emerging concepts in sustainable transportation: green vehicles and green roads	9
5	Sustainable public transport: Promoting public transport, Transit oriented development, integrated multi-modal transport.	7

### Text Books

1. Chisty, J, Lall, K. Introduction to Transportation Engineering. PHI
2. O' Flaherty, C.A (Ed.), Transport Planning and Traffic Engineering, Elsevier.
3. Jeffrey Tumlin: Sustainable Transportation Planning: Tools for Creating Vibrant, Healthy, and Resilient Communities, John Wiley & Sons

### References

1. Green Transportation Logistics: The Quest for Win-Win Solutions Editors: Psaraftis, Harilaos N. (Ed.), Springer
2. Thomas Abdallah: Sustainable Mass Transit: Challenges and Opportunities in Urban Public Transportation.
3. Chester Patton, Public Transit Operations: The Strategic Professional
4. Sustainable and Efficient Transport: Incentives for Promoting a Green Transport Market- Edited by Ellen Eftestøl-Wilhelmsson, et al, Edward Elgar
5. Rani Iyer: Green Transport: Exploring Eco-Friendly Travel for a Better Tomorrow:
6. Smart City project reports.
7. Environmental Impact Assessment Reports on Infrastructure projects.

**Course Content and lecture Schedule:**

No.	Topic	Course Outcome	No. of Hrs
1	<b>Module 1</b>		Total: 10
1.1	Sustainability: Definition, concepts	CO1	2
1.2	Environmental impacts of infrastructure projects, depletion of natural resources and pollution.	CO1	2
1.3	Problems of present transportation systems, performance analysis. Introduction to eco-friendly systems.	CO1	6
2	<b>Module 2</b>		Total: 10
2.1	Transportation network basics: network planning, design, operation and management (elementary ideas only)	CO2	3
2.2	Measures of network performance, factors and parameters.	CO2	4
2.3	Introduction to advanced transport systems: metro, monorail, maglev, hyperloop.	CO2	3
3	<b>Module 3</b>		Total: 7
3.1	Eco-friendly transport: Necessity, Basics: reducing natural fuels	CO3	2
3.2	Eco-friendly transport network. Parameters, design, implementation.	CO3	3
3.3	Professional praxis in sustainability: concepts, practical applications. Paradigm shift: Mobility and accessibility.		2
4	<b>Module 4</b>		Total: 9
4.1	Emerging concepts in sustainable transportation: green vehicles and green roads: basics and necessity.	CO4	2
4.2	Green vehicles: minimizing fuel consumption, alternate fuels. Green pathways: sustainable design, construction,	CO4	4
4.3	Forgiving designs for safety, ITS applications.	CO4	3
5	<b>Module 5</b>		Total: 9
5.1	Sustainable public transport: Promoting public transport, Fleet management and scheduling: Concepts and tools only.	CO5	3
5.2	Transit oriented development (smart cities), integrated multi-modal transport, GIS applications.	CO5	6

5.3	Micro projects: i) Compilation of studies on green fuels and transport, with comparison. ii) A study on literature available on a typical smart city project, in the transport context, and propose designs. (may be given as assignments)		
-----	--------------------------------------------------------------------------------------------------------------------------------------------------------------------------------------------------------------------------------------------	--	--

### Model Question Paper

**APJ ABDUL KALAM TECHNOLOGICAL UNIVERSITY  
FIFTH SEMESTER B. TECH DEGREE EXAMINATION, MONTH & YEAR**

Course Code: CET383

Course Name: **Eco-friendly Transportation Systems (Minor)**

Marks:100 Duration: 3 hrs

#### PART A

**(Answer all questions. Each question carry three marks)**

1. Define sustainability with emphasis on transport.
2. List the principles of sustainability.
3. What are the fundamental elements of a transport network? How do they contribute to performance?
4. Compare metro and maglev technologies.
5. Why is an eco-friendly transport necessary? Cite a typical example.
6. Why is a paradigm shift necessary in sustainability?
7. Explain the terms: Green roads, Green fuels.
8. With a typical example, explain forgiving designs.
9. List a few methods of promoting public transport.
10. What do you understand from Transit Oriented Development?

#### PART B

**(Answer one full question from each module)**

11. a) Describe how an infrastructure project affects environment. (10)  
 b) What are the issues with present transport systems? (4)

**OR**

- 12 a) When is a system deemed eco-friendly? Explain in transport context. (6)

b). What are the parameters of performance analysis of transportation systems? Explain (8)

13 a) With a typical example, illustrate the performance evaluation of a transport network(6)

b) What is hyperloop? Is it eco-friendly? How? (8)

**OR**

14a) Describe the process of network planning, design, operations and management (10)

b) What are the challenges faced by metro rail systems? (4)

15a) Explain the principles of an eco-friendly transport network (8)

b) Discuss the term professional praxis in a sustainability scenario. (6)

**OR**

16 a) How is the eco-friendliness of a transport network evaluated? Discuss the steps involved(8)

b) Explain the factors involved in designing an eco-friendly network (6)

17 a) List the alternate fuels for transport and discuss any two (6)

b) Define ITS. What are its application in eco-friendly transport. Explain any two. (8)

**OR**

18 a) Discuss any two eco-friendly construction methods for roads (8)

b) What are the methods of reducing fuel consumption in vehicles (6)

19a) Write a note on public transport fleet management. (6)

b) /what is meant by integrated multi-modal transport? Discuss it's possibilities in a city in Kerala. (8)

**OR**

20 Discuss the applications of GIS and GPS in transport, explaining how eco-friendliness can be achieved. (14)

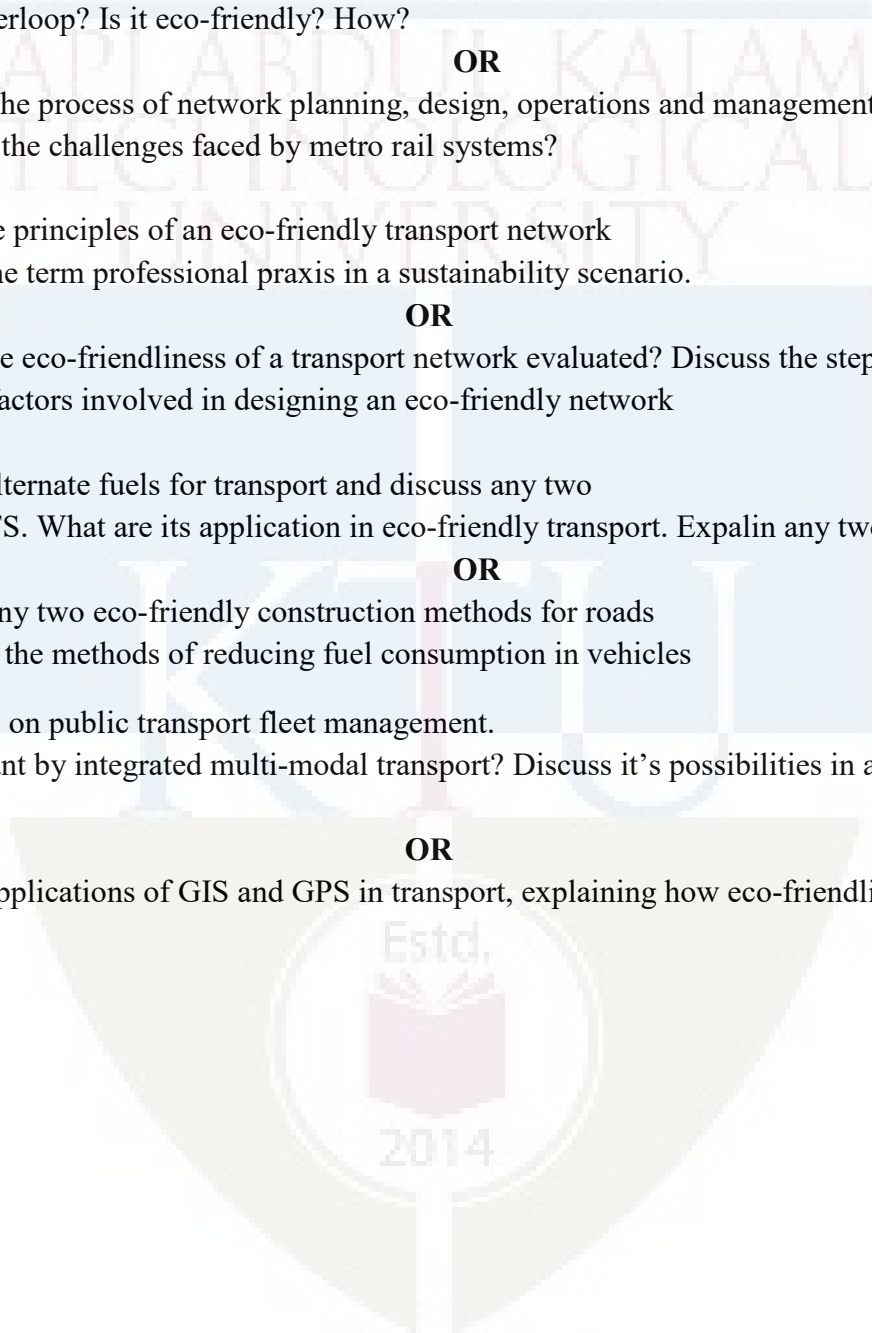

CET 385	SUSTAINABILITY ANALYSIS AND DESIGN	CATEGORY	L	T	P	CREDIT	Year of Introduction
		VAC	4	0	0	4	2019

**Preamble:** Goal of this course is to introduce various tools and techniques of sustainability analysis and its significance in design and engineering decision making.

**Prerequisite:** Nil

**Course Outcomes:** After completion of the course the student will be able to:

Course outcome identifier	Description of course outcome	Prescribed learning level
CO 1	Identify the impacts of various materials and processes on the biosphere	Remembering
CO2	Identify the parameters used in the calculation of sustainability	Understanding
CO 3	Estimate sustainability metrics for application-material combinations.	Applying
CO 4	Apply the design approaches by integrating sustainability concepts	Applying

**Mapping of course outcomes with program outcomes (Minimum requirement)**

	PO 1	PO 2	PO 3	PO 4	PO 5	PO 6	PO 7	PO 8	PO 9	PO 10	PO 11	PO 12
CO 1	1	-	-	-	-	-	-	-	-	-	-	-
CO 2	1	2	-	-	-	-	-	-	-	-	-	-
CO 3	2	3	2	-	2	-	-	-	-	-	-	-
CO 4	2	3	2	-	2	-	-	-	-	-	-	-
CO5												

**Assessment Pattern**

Bloom's Category	Continuous Assessment Tests		End Semester Examination (Marks)
	Test 1 (Marks)	Test 2 (Marks)	
Remember	7.5	7.5	30
Understand	7.5	7.5	30
Apply	10	10	40
Analyse			

Evaluate			CIVIL ENGINEERING
Create			

### Mark Distribution

Total Marks	CIE (Marks)	ESE (Marks)	ESE Duration
150	50	100	3 hours

### Continuous Internal Evaluation Pattern:

Attendance	: 10 marks
Continuous Assessment Test (2 numbers)	: 25 marks
Assignment/Quiz/Course Project	: 15 marks

### End Semester Examination Pattern:

There will be two parts: Part A and Part B.

Part A contains 10 questions with 2 questions from each module and each question shall carry 3 marks. Students should answer all questions.

Part B contains 2 questions from each module of which student should answer any one. Each question carries 14 marks and can have maximum 2 sub-divisions

### Course level Assessment Questions

**Course Outcome 1** -Identify the impacts of various materials and processes on the biosphere.

1. How are materials classified as renewable and non-renewable?
2. Compare infinitely available and regenerative renewable resources.
3. Prepare a short description on zero waste production system.

**Course Outcome 2** -Identify the parameters used in the calculation of sustainability

1. Compare “output pulled” and “input pushed” systems
2. Prepare short note on “dematerialization” and “remanufacturing”.
3. Explain ecological footprint

**Course Outcome 3** -Estimate sustainability metrics for application-material combinations

1. Illustrate the significance of biomimicry taxonomy in sustainable design.
2. How is global warning potential assessed?
3. Illustrate water foot print of a process.

**Course Outcome 4** - Apply the design approaches by integrating sustainability concepts

1. Illustrate the role of biomimicry in the design for sustainability approaches.
2. Explain the significance of “cradle to cradle” design concept.



3. List any five commonly used life cycle impact categories

## Syllabus

### Module 1

Introduction to sustainability - Sustainable use of materials: Energy, ecology and natural resources

Engineering design process-Role of materials in design: important material characteristics, construction ecology and metabolism - specifications and market.

### Module 2

Material flow analysis - efficiencies in mass flow — Constructing a material flowsystem—embodied energy—engineering models based on waste and materials management

### Module 3

Sustainability metrics — mass balance and footprint concept Sustainable design - Specifications for sustainable material use — waste management and material life cycles - Environmentally sensitive design — Green engineering

### Module 4

Life-cycle assessment—Life cycle assessment framework-Inventory analysis —impact assessment – interpretation

### Module 5

Sustainable designs approaches - Sustainable urbanization – sustainable cities –sustainable transport - energy efficiency.

### Text Books:

1. Allen,D.TandShornard,DR,SustainabilityEngineering,Concepts,DesignandCase Studies, Prentice Hall.
2. BradleyA.S.,Adebryo,A.O.,MariaP,EngineeringApplicationsinSustainableDesignand Development, Cengage Learning

### References:

1. UNDP (1987), Our Common Future, Report of the World Commission on Environment and Development
2. Riley,D.R.,Thatche,C.E.,andWorkman,E.A.(2006),Developingandapplyinggreen building technology in an indigenous community: An engaged approach to sustainability education,InternationalJournalofSustainabilityinHigherEducation,7(2),142-157.
3. LSF-LST (2007). Understanding Sustainability, Learning for a Sustainable Future, <http://www.lsf1st.cz/en/teachers/understanding.php>,YorkUniversity,Ontario,Canada.
4. ASCE (2004), Sustainable Engineering Practice: An Introduction, Jorge A. Vanegas(Editor).

5. USGBC (2008), LEEA Rating Systems, US Green Building Council, <http://www.usgbc.org/DisplayPage.aspx?CMSPageID=222>(2008), Thematic Strategy on the prevention and recycling of waste, The European Commission, <http://ec.europa.eu/environment/waste/index.htm>

**Course Contents and Lecture Schedule:**

No.	Topic	Course Outcome	No. of Hrs
1	<b>Module 1</b>		Total: 9
1.1	Introduction to sustainability - Sustainable use of materials	CO1, CO2	2
1.2	Energy, ecology and natural resources	CO1, CO2	3
1.3	Engineering design process-Role of materials in design	CO1, CO2	2
1.4	Construction ecology and metabolism - specifications and market	CO1, CO2	2
2	<b>Module 2</b>		Total: 9
2.1	Material flow analysis - efficiencies in mass flow	CO1, CO2 CO3	3
2.2	Constructing a material flowsystem—embodied energy	CO1, CO2 CO3	3
2.3	Embodied energy	CO2, CO3	1
2.4	Engineering <i>models</i> based on waste and materials management	CO2, CO3	2
3	<b>Module 3</b>		Total: 9
3.1	Sustainability metrics — mass balance and footprint concept Sustainable design	CO1, CO2 CO3, CO4	2
3.2	Specifications for sustainable material use	CO1, CO2 CO3, CO4	3
3.3	Waste management and material life cycles	CO3, CO4	2
3.4	Environmentally sensitive design — Green engineering	<b>CO3, CO4</b>	2
4	<b>Module 4</b>		Total: 9
4.1	Life-cycle assessment—Life cycle assessment framework	CO1, CO2 CO3, CO4	3
4.2	Inventory analysis	CO1, CO2 CO3, CO4	3
4.3	impact assessment – interpretation	CO1, CO2 CO3, CO4	3
5	<b>Module 5</b>		Total: 9
5.1	Sustainable designs approaches	CO1, CO2 CO3, CO4	3
5.2	Sustainable urbanization – sustainable cities	CO1, CO2 CO3, CO4	3
5.3	Sustainable transport - energy efficiency.	CO3, CO4	3

QP CODE:

Reg No.: \_\_\_\_\_

Name: \_\_\_\_\_

**ABDUL KALAM TECHNOLOGICAL UNIVERSITY**  
FIFTH SEMESTER B.TECH DEGREE EXAMINATION, MONTH & YEAR

**Course Code: CET 385**

**Course Name: SUSTAINABILITY ANALYSIS AND DESIGN**

Max. Marks: 100

Duration: 3 hours

*Answer All Questions- 10 ×3 =30marks*

*Each question carries 3marks*

1. Narrate any one material characteristic that is needed to ensure sustainability.
2. Highlight any one approach that could enable products in the market to be preferred on environmental performance.
3. State any one of the observation from material flow analysis that would supplement sustainability evaluation.
4. What is embodied energy of a material?
5. Define footprint based sustainability indicators.
6. Illustrate the term “Reuse factor”
7. Additive operations in LCA
8. LCA helps to arrive at lower entropy form of a material. Substantiate the statement giving any one reason.
9. Prepare a short account on sustainable urbanization
10. How is energy efficiency linked with sustainable design process.

**PART B**

*Each question carries 14marks*

11. Identify any three engineering materials that are used as environmental substitutes for the conventional systems. Also narrate the factors considered in their selection based on engineering design requirement.
- or
12. Explore the possibility of creating ecosystem based approach for construction process and highlight its significance to ensure sustainability.
- or
13. “Buildings embody large quantity of material energy”. Prepare a short description narrating how this resource could be used to create energy efficient material use road map for Kerala.
- or
14. Establish the industrial ecological model as an outcome of engineering models proposed for waste and material management.

15. Explore the possibility of creating ecosystem based approach for construction process and highlight its significance to ensure sustainability. Case based justification is expected.

or

16. Explain a few interventions incorporated as part of design for environment concept for improving the material handling process.

17. Explain the four major steps involved in the LCA programme.

or

18. (i) List any two challenges faced while implementing the LCA for an impact assessment programme.

(ii) Justify ,giving two reasons, how LCA enables to take environmentally informed decisions

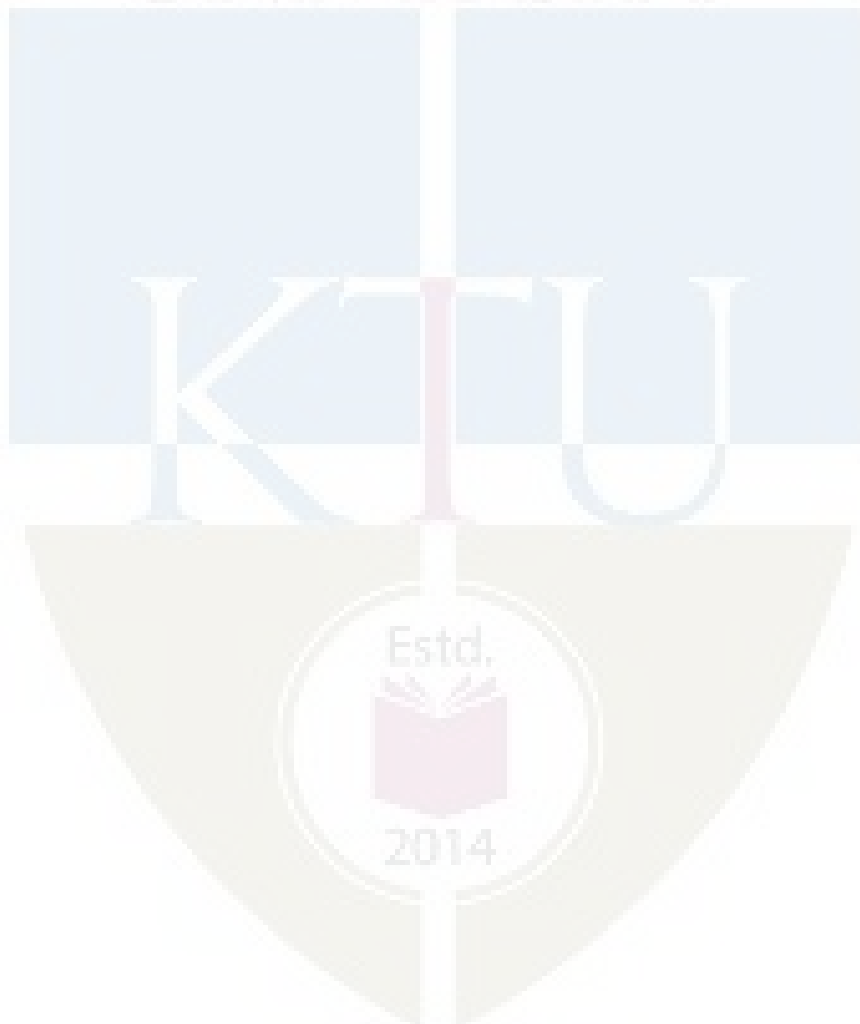

APJ ABDUL KALAM  
TECHNOLOGICAL  
UNIVERSITY

**SEMESTER V**

**HONOURS**

KTU





Bloom's Category	Continuous Assessment Tests		End Semester Examination
	1	2	
Remember/ Understand	15	15	30
Apply	35	35	70
Analyse			
Evaluate			
Create			

**Mark distribution**

Total Marks	CIE	ESE	ESE Duration
150	50	100	3 hours

**Continuous Internal Evaluation Pattern:**

Attendance : 10 marks

Continuous Assessment Test (2 numbers) : 25 marks

Assignment/Quiz/Course project : 15 marks

**End Semester Examination Pattern:** There will be two parts; Part A and Part B. Part A contain 10 questions with 2 questions from each module, having 3 marks for each question. Students should answer all questions. Part B contains 2 questions from each module of which student should answer any one. Each question carries 14 marks and can have maximum 2 sub-divisions.

**Course Level Assessment (Sample) Questions**

**CO1: Explain the basic terms and principles associated with structural dynamics.**

1. State and explain D'Alembert's principle.
2. How do you model a system for dynamic analysis?
3. What are the components of a dynamic system? Explain.
4. What is natural frequency of a dynamic system?
5. Explain critically damped, over damped and under damped systems.
6. What is damping ratio? What is its significance?
7. Write short notes on 'transient state' and 'steady state' responses.
8. Explain 'dynamic magnification factor'.
9. What is 'impulse response function'? What is its significance?

10. Write short notes on ‘Duhamel integral’.
11. Define ‘Transmissibility’ and explain its use in the design of vibration isolation systems.
12. State and derive the orthogonality properties of mode shape vectors.
14. Explain proportional and non-proportional damping models.
14. Write short notes on ‘earthquake response spectrum’.

**CO2: Model single and multi degree freedom systems for dynamic analysis and develop equations of motion.**

1. Obtain the spring mass model of the system shown and develop the equation of motion. Mass of column may be neglected.

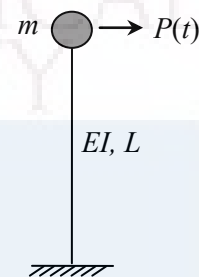

2. A simply supported beam of span  $L$  carried a central concentrated mass  $M$ . Model the system for analysis of transverse vibrations. Neglect mass of the beam and damping. The flexural rigidity of the beam is  $EI$ .

3. Develop spring mass model of the System shown.  
Take  $m = 30$  kg,  $EI_1 = 4000$  Nm<sup>2</sup>,  
 $EI_2 = 3200$  Nm<sup>2</sup>,  $l = 1$  m and  $k = 2500$  N/m.

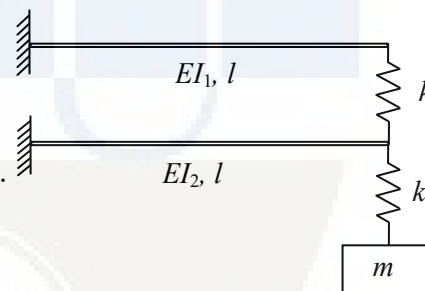

4. A rigid bar of length  $L$  is hinged at one end and carries a mass  $m$  at the other end. The bar is kept in a horizontal position with the support of a spring of stiffness  $k$  placed at a distance  $a$  from the hinged end. Formulate the equation of motion. Neglect mass of the bar and damping.

5. Develop spring- mass model of the following frame.

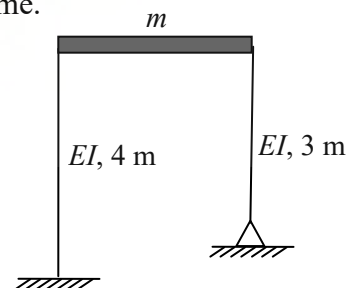



**CO3: Estimate parameters of dynamic systems**

1. Estimate the stiffness of the system shown in sample Qn. 3 of CO1.
2. A free vibration test is conducted on an empty elevated water tank. A cable attached to the tank applies a horizontal force of 100 kN and pulls the tank horizontally by 40 mm. The cable is suddenly cut and the resulting free vibration is recorded. At the end of four complete cycles, the time is 2 s and the amplitude is 25 mm. From these data compute the following: (a) damped natural frequency, (b) damping ratio, (c) effective stiffness and (d) effective mass
3. Figure shows the time history of displacement response of a SDOF system, of mass 50 kg, undergoing free vibration. Estimate the damped natural frequency, damping ratio and undamped natural frequency of the system. Also determine the stiffness and damping coefficient of the system.

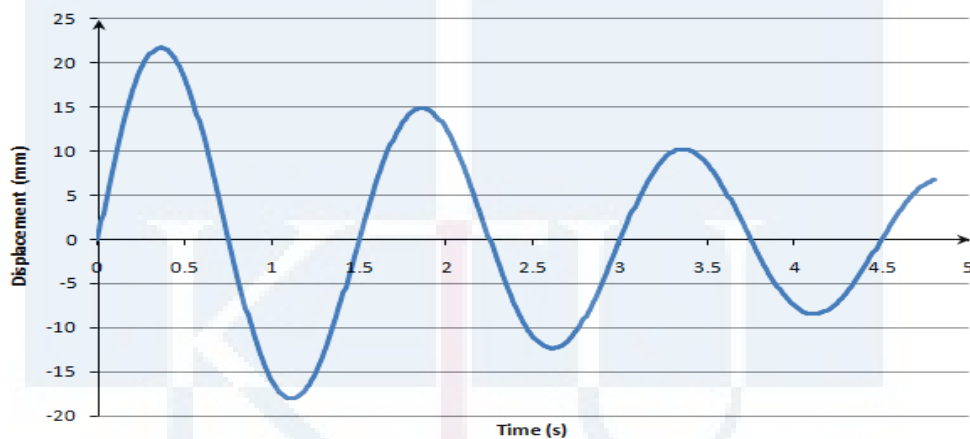

4. A portable harmonic loading machine is used to conduct a test on a single storied building. Harmonic loads of magnitude 2000 N are applied at the floor level at two different frequencies. The data is given below.

Frequency of load (rad/s)	Response Amplitude (cm)	Phase angle (degree)
8	1.50	7
10	2.25	13

Estimate the mass, stiffness and damping of the system assuming it as a single degree of freedom system.

**CO4: Perform dynamic analysis of single and multi degree freedom systems.**

1. Calculate the natural frequency and natural period of transverse vibrations of a cantilever beam 50 mm diameter circular section carrying a load of 600 N at the free end. Span of the cantilever is 1.0 m. Modulus of elasticity of the material of the beam is 205 GPa. If a spring of stiffness 50 kN/m is introduced between the load

and the beam, calculate the change in the natural frequency and natural period.

- A SDOF system with mass 20 kg and stiffness 1800 N/m is given an initial displacement of 10 mm and initial velocity of 250 mm/s. Find the displacement of the system at  $t = 1.0$  s. Also find the maximum displacement of the system. Neglect damping.
- A single degree of freedom system with mass 100 kg and stiffness 5000 N/m is subjected to a harmonic load of amplitude 25 N and frequency 6 rad/s. Assuming 10% of critical damping find the steady state amplitude. If the frequency of load is varied, at what frequency the steady state amplitude will reach maximum. Find the maximum value of steady state amplitude also.
- Find the natural frequencies and mode shapes of the spring-mass system shown in figure. Take  $m_1 = 20$  kg,  $m_2 = 15$  kg,  $k_1 = 1000$  N/m,  $k_2 = 1200$  N/m and  $k_3 = 900$  N/m.

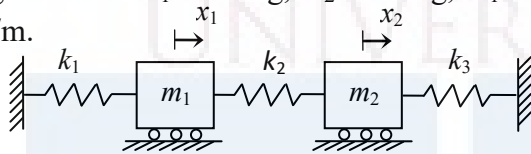

- Find the natural frequencies and mode shapes of the shear building frame shown. Sketch the mode shapes. Flexural rigidity of the columns =  $2 \times 10^6$  Nm<sup>2</sup>. Work out the mass normalized mode shape vectors also.

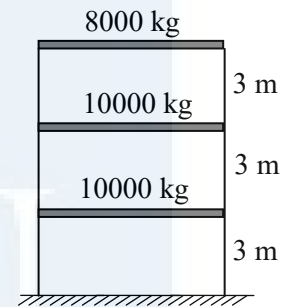

- Determine the free vibration response of a two storied frame having the following properties: Mass of first floor - 1200 kg, Mass of second floor - 800 kg, Stiffness of first storey columns - 50 kN/m and Stiffness of second storey columns - 30 kN/m. The initial displacements of first and second stories are 5 mm and 12 mm respectively.
- For a two degrees of freedom lumped mass system,

$$M = \begin{bmatrix} m & 0 \\ 0 & 2m \end{bmatrix}; \quad K = \begin{bmatrix} 2k & -k \\ -k & 3k \end{bmatrix} \quad \text{and the modal matrix } \Phi = \begin{bmatrix} 1 & 1 \\ 1 & -0.5 \end{bmatrix}. \quad \text{The}$$

natural frequencies are given by  $\omega_1^2 = \frac{k}{m}$  and  $\omega_2^2 = \frac{5}{2} \frac{k}{m}$ . The first mass of the system is subjected to a harmonic force  $P_0 \cos(\Omega t)$ . Determine the response of each of the masses. Neglect damping.

- For the frame shown in figure the natural frequencies are 15.81 rad/s and 31.62 rad/s. The modal matrix  $\Phi = \begin{bmatrix} 1 & 1 \\ 2 & -1 \end{bmatrix}$ . Obtain the response of the floors due to a constant ground acceleration of  $2 \text{ m/s}^2$ . Also, calculate

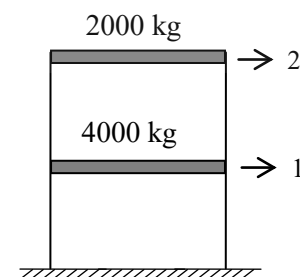

the floor displacements at  $t = 1$  s.

**CO5: Analyse and design vibration isolation systems.**

1. An instrument is attached to a rubber mounting having a static deflection of 3.6 mm. The supporting structure vibrates at a frequency of 30 Hz. If the damping is 3% of critical, estimate the % reduction in the transmitted support motion.
2. A delicate instrument of weight 200 kg is to be mounted on a factory floor using a vibration isolation suspension. The floor is vibrating with an amplitude of 0.25 mm and frequency 15 Hz. The maximum displacement that can be tolerated by the instrument for reliable operation is 0.1 mm. Find the stiffness of the suspension springs assuming 5% of critical damping.
3. A vibration isolation block (as shown in figure) is to be installed in a laboratory so that the vibration from adjacent factory operations will not disturb certain experiments. If the isolation block weighs 900 kg and the surrounding floor and foundation vibrates at 1500 cycles/minute, determine the stiffness of the isolation system such that the motion of the isolation block is limited to 20% of floor vibration. Assume damping as 10%.

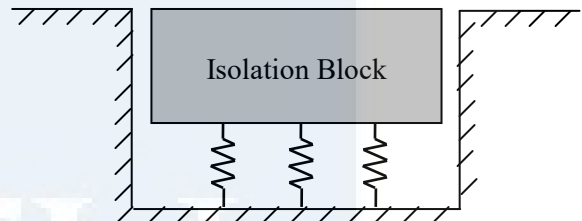

**CO6: Develop equations of motion for dynamic analysis of beams and perform free vibration analysis of simply supported beam.**

1. Derive the differential equation governing the flexural vibration of beams.
2. Find the first three natural frequencies and mode shapes of a simply supported beam of span  $L$  having uniform flexural rigidity  $EI$  and mass  $\bar{m}$  per unit length. Sketch the mode shapes also.
3. A steel rod of 20 mm diameter having length 2.0 m is simply supported at its ends. Find its fundamental frequency of flexural vibration. Take density of steel as  $7850 \text{ kg/m}^3$ . Modulus of elasticity of steel may be taken as 200 GPa.

**Module I**

Introduction – Parameters of dynamic system – D'Alembert's principle, Equation of motion of SDOF systems – undamped free vibration analysis. Damped free vibration analysis. Measurement of damping – Logarithmic decrement, Response to harmonic loading - steady state and transient states – steady state amplitude, Dynamic magnification factor.

**Module II**

Response of SDOF systems to rectangular load, triangular load and half sine pulse. Impulse response function, Response to general loads-Duhamel's integral. Response of SDOF system to support motion, Vibration Isolation, transmissibility

**Module III**

Multi degree of freedom systems – Lumped mass systems, shear building frame, Equation of motion, free vibration analysis, Natural frequencies and mode shapes, orthogonality of normal modes.

**Module IV**

Forced vibration analysis of multi degree of freedom systems – mode superposition method. Response of MDOF systems subjected to harmonic load. MDOF system subjected to support motion.

**Module V**

Introduction to earthquake analysis - Response spectrum. Response spectrum analysis of MDOF systems. Distributed parameter systems, Differential equation – beam flexure (elementary case), undamped free vibration analysis of simply supported beams.

**Text Books:**

- 1) Mario Paz, *Structural Dynamics*, CBS Publishers, New Delhi, India, 2001.
- 2) Mukhopadhyay M., *Vibrations, Dynamics and Structural Systems*, Taylor & Francis, London, 2000.

**References:**

- 1) Clough R. W. and J. Penzien, *Dynamics of Structures*, McGraw Hill, 1993.
- 2) Chopra A. K., *Dynamics of Structures- Theory and application to Earthquake Engineering*, Pearson Education India, 2007.
- 3) Biggs J. M., *Introduction to Structural Dynamics*, McGraw-Hill Book Inc., New York, 1964.
- 4) J.W. Smith, *Vibration of Structures*, Chapman and Hall, London.

Module	Topic	Course Outcomes addressed	No. of Lectures
<b>1</b>	<b>Module I : Total lecture hours : 10</b>		
1.1	Introduction to structural dynamics and its importance in Civil Engineering. Dynamic Load, Parameters of dynamic system	CO1	1
1.2	D'Alembert's principle, Equation of motion of SDOF system. Undamped free vibration analysis, concept of natural frequency	CO1, CO2	1
1.3	Modeling systems as SDOF spring-mass model, estimation of stiffness, determination of natural frequency	CO2, CO3	2
1.4	Free vibration response of undamped SDOF systems	CO4	1
1.5	Damped free vibration analysis – concept of critical damping and damping ratio, underdamped and overdamped systems	CO1, CO4	1
1.6	Free vibration response of damped SDOF systems – measurement of damping – logarithmic decrement.	CO1, CO3, CO4	1
1.7	Response of damped SDOF systems to harmonic loading – transient state and steady state responses. Response of undamped SDOF systems to harmonic loading.	CO1, CO4	2
1.8	Steady state amplitude, Dynamic magnification factor, concept of resonance, frequency response plot of SDOF systems.	CO1, CO4	1
<b>2</b>	<b>Module II : Total lecture hours : 10</b>		
2.1	Response of undamped and damped SDOF systems to rectangular load.	CO4	1
2.2	Response of undamped and damped SDOF systems to triangular load.	CO4	2
2.3	Response of undamped and damped SDOF systems to half sine pulse.	CO4	1
2.4	Impulse response function for undamped and damped systems Response to general load – concept of Duhamel's integral.	CO1, CO4	1
2.5	Response of undamped and damped SDOF systems to support motion.	CO4	2
2.6	Vibration isolation – force and displacement isolation, Transmissibility ratio.	CO1, CO5	2

2.7	Design of vibration isolation systems	CO5	1
<b>3</b>	<b>Module III : Total lecture hours : 10</b>		
3.1	Multi-degree of freedom (MDOF) systems- examples, Lumped mass systems, Shear building frames	CO1, CO4	1
3.2	Modelling of MDOF systems, Equation of motion	CO2, CO3	2
3.3	Undamped free vibration analysis, Natural frequencies and mode shapes, orthogonality of mode shapes	CO1, CO4	3
3.4	Mode superposition method - Free vibration response of undamped MDOF systems	CO1, CO4	2
3.5	Mode superposition method -Free vibration response of damped MDOF systems, concept of modal damping.	CO1, CO4	2
<b>4</b>	<b>Module IV : Total lecture hours : 8</b>		
4.1	Forced vibration analysis - Mode superposition method.	CO1, CO4	1
4.2	Response of MDOF systems subjected to harmonic load. Maximum modal responses and modal combination using SRSS rule.	CO1, CO4	3
4.3	MDOF system subjected to support motion – Equation of motion.	CO2	1
4.4	Response of shear building frames subjected to support acceleration - maximum floor response using SRSS rule.	CO2, CO4	2
4.5	Concept of frequency response function (FRF) of MDOF systems.	CO1	1
<b>5</b>	<b>Module V : Total lecture hours : 7</b>		
5.1	Introduction to earthquake analysis, Response spectrum – concept, Development of response spectrum	CO1	1
5.2	Response spectrum analysis of MDOF systems.	CO4	2
5.3	Distributed parameter systems, Differential equation for beam flexure (elementary case) and its solution	CO1, CO6	2
5.4	Undamped free vibration analysis of simply supported beam – natural frequencies and mode shapes	CO6	1
5.5	Undamped free vibration analysis of beams with different boundary conditions (formulation only)	CO6	1

Reg.No.: \_\_\_\_\_

Name: \_\_\_\_\_

**APJ ABDUL KALAM TECHNOLOGICAL UNIVERSITY**  
**FIFTH SEMESTER B.TECH DEGREE EXAMINATION**

**Course Code: CET393**

**Course Name: STRUCTURAL DYNAMICS**

Max. Marks: 100

Duration: 3 Hours

**PART A**

*Answer all questions; each question carries 3 marks.*

1.
  - a) Explain critically damped, over damped and under damped systems.
  - b) Distinguish between 'transient state' and 'steady state' responses.
  - c) What is 'impulse response function'? What is its significance?
  - d) Define 'Transmissibility' and explain its use in the design of vibration isolation systems.
  - e) What do you mean by shear building frames?
  - f) Explain orthogonality of mode shapes.
  - g) Explain mode superposition method of analysis.
  - h) Derive the equation of motion of a two storied shear building frame subjected to support motion.
  - i) What is earthquake response spectrum?
  - j) Derive the partial differential equation governing the flexural vibration of beams. Neglect damping and effect of axial force.

(10×3 marks = 30 marks)

**PART B**

*Answer one full question from each module; each full question carries 14 marks.*

**Module I**

2. A free vibration test is conducted on an empty elevated water tank. A cable attached to the tank applies a horizontal force of 100 kN and pulls the tank horizontally by 40 mm. The cable is suddenly cut and the resulting free vibration is recorded. At the end of four complete cycles, the time is 2 s and the amplitude is 25 mm. From these data compute the following: (a) damped natural frequency, (b) damping ratio, (c) effective stiffness, (d) effective mass and (e) amplitude of displacement after 10 cycles.
3. A portable harmonic loading machine is used to conduct a test on a single storied building. Harmonic loads of magnitude 2000 N are applied at the floor level at two different frequencies. The data is given below.

Frequency of load(rad/s)	Response Amplitude(cm)	Phase angle(degree)
--------------------------	------------------------	---------------------

8	1.50	CIVIL ENGINEERING
10	2.25	13

Estimate the mass, stiffness and damping of the system assuming it as a single degree of freedom system

### Module II

4. A single degree of freedom system with  $m = 10$  kg and  $k = 1.2$  kN/m is subjected to a half sine load as shown in figure. Find expressions for the displacement of the system for  $t < 0.4$  s and  $t > 0.4$  s. Neglect damping. Assume that the system starts from rest.

What is the displacement at  $t = 0.4$  s ?

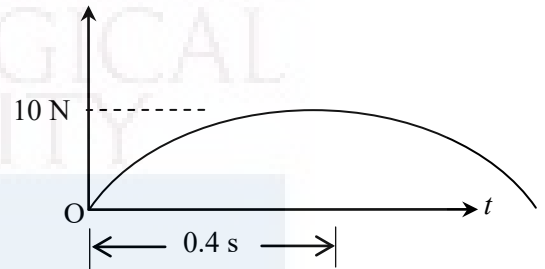

5. A sieving machine weighs 2500 kg and when operating at full capacity, it exerts a harmonic force of 3 kN amplitude at 20 Hz on its supports. After mounting the machine on spring-type vibration isolators, it was found that the amplitude of the harmonic force exerted on the supports had been reduced to 250 N. Determine the stiffness of the isolator springs. Assume damping as 10% of critical.

### Module III

6. Find the natural frequencies and mode shapes of the spring-mass system shown in figure. Take  $m_1 = 20$  kg,  $m_2 = 15$  kg,  $k_1 = 1000$  N/m,  $k_2 = 1200$  N/m and  $k_3 = 900$  N/m.

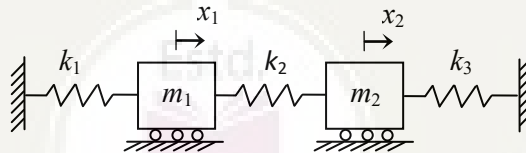

7. Determine the free vibration response of a two storied frame having the following properties: Mass of first floor - 1200 kg, Mass of second floor - 800 kg, Stiffness of first storey columns - 50 kN/m and Stiffness of second storey columns - 30 kN/m. The initial displacements of first and second stories are 5 mm and 12 mm respectively.

### Module IV

8. For a two degrees of freedom lumped mass system,

$$M = \begin{bmatrix} m & 0 \\ 0 & 2m \end{bmatrix}; \quad K = \begin{bmatrix} 2k & -k \\ -k & 3k \end{bmatrix} \quad \text{and the modal matrix } \Phi = \begin{bmatrix} 1 & 1 \\ 1 & -0.5 \end{bmatrix}. \quad \text{The natural}$$

frequencies are given by  $\omega_1^2 = \frac{k}{m}$  and  $\omega_2^2 = \frac{5}{2} \frac{k}{m}$ . The first mass of the system is subjected



to a harmonic force  $P_0 \cos(\Omega t)$ . Determine the response of each of the masses. Neglect damping.

9. For the frame shown in figure the natural frequencies are 15.81 rad/s and 31.62 rad/s. The modal matrix

$$\Phi = \begin{bmatrix} 1 & 1 \\ 2 & -1 \end{bmatrix}$$

Obtain the response of the floors due

to a constant ground acceleration of  $2 \text{ m/s}^2$ . Also, calculate the floor displacements at  $t = 1 \text{ s}$ .

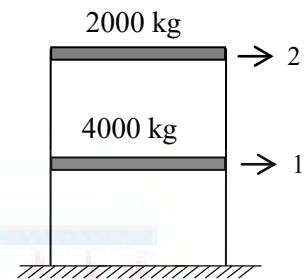

### Module V

10. Explain response spectrum analysis of MDOF shear building frames subjected to earthquake ground acceleration. Derive the relevant equations.
11. Find the first three natural frequencies and mode shapes of a simply supported beam of span  $L$  having uniform flexural rigidity  $EI$  and mass  $\bar{m}$  per unit length. Sketch the mode shapes also.

\*\*\*\*\*

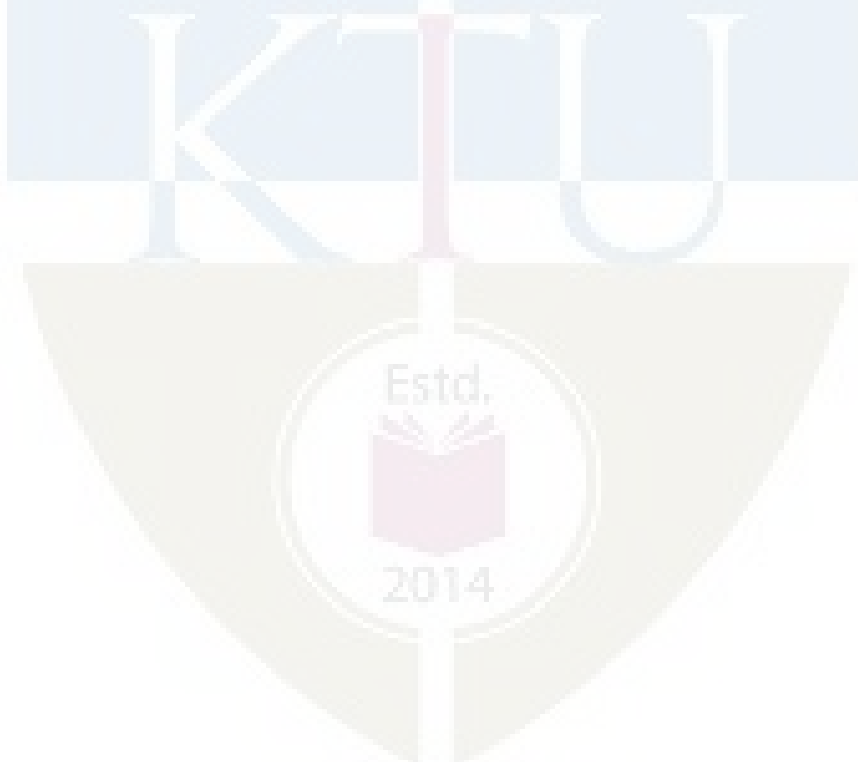

CET395	TRANSPORTATION SYSTEMS MANAGEMENT	CATEGORY	L	T	P	CREDIT	Year of Introduction
		VAC	3	1	0	4	2019

**Preamble:** Objective of the course is to impart an awareness on transportation system management, TSM strategies, promotion of non-transport modes and advanced transit technologies.

**Prerequisite:** Nil

**Course Outcomes:** After the completion of the course, the student will be able to:

CO 1	Apply a transportation system management strategy based on TSM goal or objective.
CO 2	Recommend methods to manage a transit system to improve its management efficiency.
CO 3	Recommend measures for the promotion of non-transport modes for a transportation system based on a goal or objective.
CO 4	Assess the suitability of advanced transit technologies in a transportation system.

**Mapping of course outcomes with program outcomes**

	PO 1	PO 2	PO 3	PO 4	PO 5	PO 6	PO 7	PO 8	PO 9	PO 10	PO 11	PO 12
CO 1	3	1				2		1			1	2
CO 2	2	1				2		1			1	2
CO 3	1					2	3	1			1	2
CO 4	1				1	2	1	1	1		1	2

**Assessment Pattern**

Bloom's Category	Continuous Assessment		End Semester Examination (marks)
	Test 1 Marks	Test 2 Marks	
Remember	10	10	40
Understand	10	10	40
Apply	5	5	20
Analyse			
Evaluate			
Create			

**Mark Distribution**

Total Marks	CIE (Marks)	ESE (Marks)	ESE Duration
150	50	100	3 hours

**Continuous Internal Evaluation Pattern:**

Attendance	: 10 marks
Continuous Assessment Test (2 numbers)	: 25 marks
Assignment/Quiz/Course Project	: 15 marks

**End Semester Examination Pattern:**

The question consists of two parts- Part A and Part B. Part A consists of 10 questions with 3 marks for each (two questions from each module). Part B consists of two questions from each module, out of which one has to be answered. Each question carries 14 marks and can have maximum 2 subdivisions.

**Sample Course Level Assessment Questions:**

**Course Outcome 1 (CO1):** Recommend and discuss two methods for reducing peak period traffic?

**Course Outcome 2 (CO2):** Identify the issues of multi-modal coordination?

**Course Outcome 3 (CO3):** As per IRC code, describe the features adopted for bicycle tracks to popularise bicycle traffic in an Indian urban area.

**Course Outcome 4 (CO4):** Discuss on whether Indian population would adapt to the various advanced transit measures popular in many developed nations.

**Syllabus****Module 1**

System approach to Transportation Planning; The need for TSM, Long range versus TSM Planning TSM characteristics: TSM planning cycle, TSM strategies, Objectives and Philosophy; Relevance of TSM actions in Indian context. Measures for Improving vehicular flow – one-way Streets, Signal Improvement, Transit Stop Relocation, Parking Management, Reversible lanes- Reducing Peak Period Traffic – Strategies for working hours, Congestion Pricing; Traffic calming measures

**Module 2**

Public Transport: Preferential Treatment to high Occupancy Vehicles; Transit system operations, Service and characteristics, Transit Service Improvement Measures; Car Pooling; Transit Management Improvement Measure; Multi-Modal Coordination; Transit and Para transit integration;

**Module 3**

Bus Route Network Planning and Management: Type of Bus Route Networks; Suitability for a given Urban Area; Types of routes – Corridor routes, activity routes and residential routes; Issues in route networks evaluation – number of route, length of route; Route alignment methods; service coverage and accessibility index.

**Module 4**

Local area traffic management: Promotion of Non – motorised modes: Measures to promote; Pedestrianisation: Pedestrian facilities and management. Bicycle Transportation – advantages; Planning Bicycle Facilities Junction Treats for cycle tracks;LOS criteria for Pedestrian and bicycle Facilities.

**Module 5**

Advanced Transit Technologies: Conventional and Unconventional Systems; Rapid Transportation System; New technologies – LRT, monorail, Automated Highways- Hovercraft; System Characteristics and Suitability.

**Text Books :**

1. C. J. Khisty and B. K. Lall, Transportation Engineering: An Introduction, Prentice- Hall India, 2003.
2. Transportation Demand Management (TDM) Encyclopedia, Victoria Transport Policy Institute Canada, 2006.

**References:**

1. Transportation Engineering and Planning, by C. S. Papacostas and P. D. Prevedouros, PrenticeHall of India Private Limited 2001
2. Roger P. Roess, William R. McShane & Elena S. Prassas, Traffic Engineering, Prentice-Hall, 1990.

**Course Content and lecture Schedule:**

No.	Topic	Course Outcome	No. of Hrs
1	<b>Module 1</b>		Total: 9
1.1	System approach to Transportation Planning; The need for TSM, Long range verses TSM Planning	CO1	1
1.2	TSM characteristics: TSM planning cycle, TSM strategies, Objectives and Philosophy; Relevance of TSM actions in Indian context.	CO1	1
1.3	Measures for Improving vehicular flow – one-way Streets, Signal Improvement, Transit Stop Relocation, Parking Management, Reversible lanes- Reducing Peak Period Traffic –	CO1	7

	Strategies for working hours, Congestion Pricing.		
2	<b>Module 2</b>		Total: 9
2.1	Public Transport: Preferential Treatment to high Occupancy Vehicles; Transit system operations, Service and characteristics, Transit Service Improvement Measures; Car Pooling;	CO2	4
2.2	Transit Management Improvement Measure; Multi-Modal Coordination; Transit and Para transit integration;	CO2	5
3	<b>Module 3</b>		Total: 9
3.1	Bus Route Network Planning and Management: Type of Bus Route Networks; Suitability for a given Urban Area;	CO2	2
3.2	Types of routes – Corridor routes, activity routes and residential routes;	CO2	2
3.3	Issues in route networks evaluation – number of route, length of route;	CO2	2
3.4	Route alignment methods; service coverage and accessibility index.	CO2	3
4	<b>Module 4</b>		Total: 9
4.1	Local area traffic management: Promotion of Non – motorised modes: Measures to promote;	CO3	1
4.2	Pedestrianisation: Pedestrian facilities and management. IRC codes.	CO3	2
4.3	Bicycle Transportation – advantages; Planning Bicycle Facilities Junction Treats for cycle tracks; IRC codes for bicycle facilities.	CO3	4
4.4	LOS criteria for Pedestrian and bicycle Facilities.	CO3	2
5	<b>Module 5</b>		Total: 9
5.1	Advanced Transit Technologies: low carbon vehicles; Automated Highways: System Characteristics and Suitability, Electric vehicles, Automated vehicles: Planning, infrastructure and implementation; issues.	CO4	4
5.2	Rapid Transportation System; New technologies – LRT, monorail, Bus rapid transit system (BRTS), Rail rapid transit system(RRTS).	CO4	5

**Model Question Paper**

**APJ ABDUL KALAM TECHNOLOGICAL UNIVERSITY  
FIFTH SEMESTER B. TECH DEGREE EXAMINATION, MONTH & YEAR**

Course Code: **CET395**

Course Name: **TRANSPORTATION SYSTEMS MANAGEMENT**

Marks:100

Duration: 3 hrs

**PART A**

**(Answer all Questions: Each question carries 3 marks)**

- 1 Mention the need for Transportation System Management.
- 2 Discuss about the relevance of TSM actions in Indian context?
- 3 What are the issues related to transit and para transit integration?
- 4 Discuss about carpooling.
- 5 What are the strategies adopted for fixing suitable bus network for a given Urban Area?
- 6 Comment on how to arrive at an accessibility index for a transit route.
- 7 Suggest the measures to be taken to promote NMT in Indian cities.
- 8 What considerations are to be made for planning proper bicycle Facilities for an urban area?
- 9 Mention some important features suggested for automated highways.
- 10 Why should planners recommend BRTS for urban areas?

(3 x 10=30 marks)

**PART B**

**(Answer one full question from each module)**

- |           |                                                                      |   |
|-----------|----------------------------------------------------------------------|---|
| 11 a.     | Describe the system approach to transportation planning              | 7 |
| b.        | What are reversible lanes? How does it help to improve traffic flow? | 7 |
| <b>OR</b> |                                                                      |   |
| 12 a.     | Mention the objectives of TSM?                                       | 7 |
| b.        | How is congestion pricing carried out to improve traffic flow?       | 7 |
| 13 a.     | What are the service characteristics of transit operations?          | 7 |
| b.        | List out the five pillars of multi-modal integration? Explain each.  | 7 |

**OR**

- |    |                                                                              |    |
|----|------------------------------------------------------------------------------|----|
| 14 | List out the preferential treatments to High Occupancy Vehicles. Explain any | 14 |
|----|------------------------------------------------------------------------------|----|

five in detail.

15 Compare and contrast the different route adopted under network planning strategies. 14

OR

16 a. How do you evaluate the effectiveness of bus route network? 7

b. Describe in detail any method adopted by planners to align route in the urban road networks. 7

17 a. List down the characteristics of Non – motorised modes of traffic. 7

b. How can the LOS criteria for Pedestrian formulated? 7

OR

18 a. Suggest the modifications to be adopted in an urban roadway to enhance the pedestrian facilities in reference to the IRC codes. 7

b. Discuss the Junction Treatments to be facilitated for laying cycle tracks. 7

19 a. What are the infrastructural facilities required for a properly planned electric transit vehicle system in a typical Indian city 7

b. Compare and contrast any two popular Rapid Transportation Systems. 7

OR

20 a. What are the infrastructural and service characteristics advised for a typical Indian city to be employed with an automatic highway? 7

b. What are the measures that can be adopted for enhancing the usage of rail as a transit mode? 7



CET397	GROUND WATER HYDROLOGY	Category	L	T	P	Credit	Year of Introduction
		VAC	3	1	0	4	2019

**Preamble:** The general objective of this course is to expose the students to the fundamental concepts of groundwater hydrology and its engineering applications. The course aim to impart the knowledge on the hydraulics of subsurface fluid flow, characteristics of porous media, well flow near aquifer boundaries, surface investigation of ground water, quality of ground water, artificial recharge and ground water flow modeling.

**Pre-requisite:** NIL

**Course outcome**

After the course, the student will be able to:

CO1	Understand the occurrence and movement of ground water through porous media and apply Darcy’s law to simple ground water flow problems
CO2	Determine the aquifer parameters using different methods
CO3	Estimate drawdown in wells due to the effect of aquifer boundaries and thickness of aquifers
CO4	Estimate sea water intrusion length and fresh water discharge into the sea
CO5	Perform numerical modeling of ground water system

**CO-PO Mapping**

CET397 Ground Water Hydrology		PO1	PO2	PO3	PO4	PO5	PO6	PO7	PO8	PO9	PO10	PO11	PO12
	CO1	3	3					1					
	CO2	3	3					1					
	CO3	3	2					1					
	CO4	3	3					1					
	CO5	3	3					1					



**Assessment pattern**

Bloom's Category	Continuous Assessment Tests		End Semester Examination (Marks)
	Test 1 (Marks)	Test 2 (Marks)	
Remember	5	5	15
Understand	10	10	15
Apply	20	20	40
Analyze	15	15	30
Evaluate			
Create			

**Continuous Internal Evaluation Pattern:**

Attendance	:	10 marks
Continuous Assessment Test (2 numbers)	:	25 marks
Assignment/Quiz/Course project	:	15 marks
<b>Total</b>	:	<b>50 marks</b>

**End semester examination pattern** – There will be two parts; Part A and Part B. Part A contain 10 questions with 2 questions from each module, having 3 marks for each question. Students should answer all questions. Part B contains 2 questions from each module of which student should answer any one. Each question can have maximum 2 sub-divisions and carry 14 marks.

**Course Code: CET 397**  
**Ground Water Hydrology**  
**(Course plan)**

Module	Topic	Course outcome addressed	No of Hours
<b>Module I (10 Hours)</b>			
1.1	Vertical distribution of ground water-Types of geologic formations	CO1	1
1.2	Properties of aquifer related to storage and transmissivity of water	CO1	1
1.3	Darcy's law, Steady unidirectional flow	CO1	1
1.4	Steady flow in a homogenous aquifer	CO1	1

1.5	Problems from unidirectional flow	CO1	2
1.6	Aquifer with recharge	CO1	1
1.7	Flow into infiltration galleries	CO1	1
1.8	Problems	CO1	2
<b>Module II (8 Hours)</b>			
2.1	Partial differential equation governing unsteady ground water flow	CO2	1
2.2	Unsteady radial flow towards well	CO2	1
2.3	Evaluation of aquifer parameters- Theis method	CO2	1
2.4	Evaluation of aquifer parameters- Jacob's method	CO2	1
2.5	Evaluation of aquifer parameters- Chow's method	CO2	1
2.6	Problems- Evaluation of aquifer parameters	CO2	3
<b>Module III (11 Hours)</b>			
3.1	Well flow near aquifer boundaries	CO3	1
3.2	Image well system	CO3	1
3.3	Method of images –particular cases	CO3	1
3.4	Problems from method of images	CO3	2
3.5	Surface investigation of ground water	CO3	1
3.6	Electrical resistivity method	CO3	1
3.7	Seismic refraction method	CO3	1
3.8	Determination of aquifer thickness of horizontal aquifers	CO3	1
3.9	Problems- resistivity method, seismic refraction	CO3	2
<b>Module IV (9 Hours)</b>			
4.1	Quality of ground water –Graphical representations	CO4	1
4.2	Pollution of ground water-sources	CO4	1
4.3	Distribution and evaluation of ground water pollution	CO4	1
4.4	Sea water intrusion-Ghyben-Herzberg equation	CO4	1
4.5	Sea water-fresh water interface	CO4	1
4.6	Length of intrusion	CO4	1
4.7	Upconing , Sea water intrusion- preventive measures	CO4	1
4.8	Problems- Sea water intrusion	CO4	2
<b>Module V (7 Hours)</b>			
5.1	Artificial recharge of ground water- different techniques	CO5	1
5.2	Modelling of ground water flow	CO5	1
5.3	Governing equations of ground water flow and boundary conditions	CO5	1
5.4	Solution of partial differential equation of ground water flow for 1D steady ground water flow in homogenous aquifer using finite difference method	CO5	4

## **CET 397: Ground Water Hydrology Syllabus**

### **Module I**

Vertical distribution of groundwater- Types of geologic formations, Properties of aquifer related to storage and transmissivity of water, Darcy's law, Steady unidirectional flow- steady flow in a homogenous aquifer- aquifer with recharge- flow into infiltration galleries. (Problems from unidirectional flow)

### **Module II**

Partial differential equation governing unsteady groundwater flow- unsteady radial flow towards well. Evaluation of aquifer parameters by Theis, Jacob's and Chow's method. (Problems from evaluation of aquifer parameters)

### **Module III**

Well flow near aquifer boundaries- Image well system. Method of images- Practical cases (Problems from method of images). Surface investigation of ground water- different methods- electrical resistivity method, seismic refraction method- determination of aquifer thickness of horizontal aquifers (Problems from resistivity method, seismic refraction)

### **Module IV**

Quality of ground water- Graphical representations. Pollution of ground water- sources, distribution and evaluation of ground water pollution (Brief description only). Sea water intrusion- Ghyben-Herzberg equation, sea water-fresh water interface, length of intrusion, upconing, preventive measures.( Problems from sea water intrusion)

### **Module V**

Artificial recharge of ground water-different techniques. Modelling of ground water flow- governing equations of ground water flow and boundary conditions (basic ideas only), solution of partial differential equation of ground water flow for 1D steady ground water flow in homogenous aquifers (confined and unconfined) using finite difference method (uniform mesh interval only)

**Text Books:**

1. D.K. Todd, "Ground Water Hydrology", Wiley International Ed; Toppan & Company Ltd, Tokyo, 1995.
2. H.M. Raghunath, "Groundwater", New Age International Publishers, New Delhi, 2007.
3. A.K. Rastogi, "Numerical Ground Water Hydrology", Penram International Publishers, Mumbai

**References:**

1. Karanth, "Ground Water Assessment, Development and Management" Tata McGraw Hill publishing company Ltd.
2. "Ground Water Manual", A Water Resources Technical Publication.
3. S.P Garg, "Ground Water and tube wells", Oxford & IBH Publishing Company.
4. Punmia B.C. Ashok K Jain, Arun K Jain, B. B. L Pande, "Irrigation and Water Power Engineering", Laxmi Publications (P) Ltd. 2009
5. Herman Bouwer, "Ground Water Hydrology", MC Graw Hill Kogakusha Ltd.
6. H.M. Raghunath, "Ground Water Hydrology", Wiley Eastern Limited.
7. Neven Kresic, "Hydrogeology and Ground Water modeling", CRC press, Taylor & Francis group, 2007.
8. Freeze and Cherry, "Ground Water", Prentice Hall



**Course Code: CET 397**  
**Ground Water Hydrology**  
**(Course Level Assessment Questions)**

<b>Qn No</b>	<b>Question</b>	<b>Marks</b>	<b>Course outcome (CO) Assessed</b>
<b>Part A</b> <b>(Answer ALL Questions)</b>			
1	Explain different properties of aquifer	3	CO1
2	What is an infiltration gallery? Explain with figure.	3	CO1
3	Briefly explain Theis method of estimation of aquifer parameters	3	CO2
4	What are the assumptions in the derivation of partial differential equation of unsteady radial flow towards wells?	3	CO2
5	Find the number of image wells and locate the image wells when the aquifer is delimited by two converging recharge boundaries at right angles.	3	CO3
6	What are the applications of electrical resistivity method?	3	CO3
7	What are the different sources of pollution of ground water? Explain briefly	3	CO4
8	Explain upconing with neat sketch	3	CO4
9	Write the equations for the second order head gradient of an aquifer using central, forward and backward difference schemes	3	CO5
10	Write the governing equations of groundwater flow and boundary conditions	3	CO5
<b>Part B</b> <b>(Answer ANY ONE FULL question from each module)</b>			
<b>Module I</b>			
11(a)	Explain different types of aquifer with neat sketches	7	CO1
11(b)	In a field test, time of 6 hour was required for a tracer to	7	CO1

	travel between two observation wells 42 m apart. If the difference in water-table elevations in these wells were 0.85 m and the porosity of the aquifer is 20%, calculate the coefficient of permeability of the aquifer.																				
12(a)	State Darcy's law and its limitations	4	CO1																		
12(b)	Sketch a typical infiltration gallery. Derive the equation for discharge per unit length of the infiltration gallery and phreatic surface by making suitable assumptions.	10	CO1																		
<b>Module II</b>																					
13(a)	Derive partial differential equation for unsteady ground water flow	10	CO2																		
13(b)	A well of 30 cm diameter is located in a confined aquifer of transmissibility $500\text{m}^2/\text{day}$ and storage coefficient of 0.005. What pumping rate will have to be adopted if the drawdown at the well is not to exceed 10 m in 2 days.	4	CO2																		
14(a)	The time drawdown data recorded at an observation well situated at a distance of 50 m from the pumping well is given below.	9	CO2																		
	<table border="1" style="width: 100%; border-collapse: collapse;"> <thead> <tr> <th style="text-align: left;">Time (min)</th> <th style="text-align: left;">Drawdown (m)</th> </tr> </thead> <tbody> <tr><td>1.5</td><td>0.15</td></tr> <tr><td>3</td><td>0.6</td></tr> <tr><td>4.4</td><td>1</td></tr> <tr><td>6</td><td>1.4</td></tr> <tr><td>10</td><td>2.4</td></tr> <tr><td>20</td><td>3.7</td></tr> <tr><td>40</td><td>5.1</td></tr> <tr><td>100</td><td>6.9</td></tr> </tbody> </table>			Time (min)	Drawdown (m)	1.5	0.15	3	0.6	4.4	1	6	1.4	10	2.4	20	3.7	40	5.1	100	6.9
	Time (min)			Drawdown (m)																	
	1.5			0.15																	
	3			0.6																	
	4.4			1																	
	6			1.4																	
	10			2.4																	
	20			3.7																	
	40			5.1																	
100	6.9																				
If the well discharge is $1.8\text{ m}^3/\text{min}$ , calculate the transmissibility and storage coefficient of the aquifer using modified Theis method.																					
14(b)	Describe the method for the estimation of aquifer parameters by Chow's method.	5	CO2																		
<b>Module III</b>																					
15 (a)	Describe the seismic refraction method for groundwater investigation with a neat sketch.	7	CO3																		
15(b)	An aquifer is delineated by two converging barrier boundaries, the angle of wedge being $45^\circ$ . Compute the number of image wells associated with the wedge shaped	7	CO3																		

	boundary system and mark them neatly in a sketch.		
16 (a)	In a seismic refraction survey for locating an aquifer, slopes of $1.66 \times 10^{-3}$ and $0.000625$ s/m were noted from the time-distance plots. If the cross-over distance is 20.76 m, compute the depth to the aquifer, the critical shot-geophone distance, and the correct angle of incidence for the refraction along the interface.	5	CO3
16 (b)	A 30cm well is pumped at the rate of 1000 lpm. The transmissibility of the aquifer is $0.015\text{m}^2/\text{s}$ . If the well is located at a distance of 120m from a stream, what should be the drawdown  (i) In the pumping well  (ii) In an observation well 100m away from the pumping well on the side opposite to the stream  (iii) In an observation well 85m away from the pumping well, on a line parallel to the stream.	9	CO3
<b>Module IV</b>			
17(a)	Derive the relationship between length of interface and freshwater discharge in a confined aquifer.	8	CO4
17(b)	Explain different water quality plots with neat sketches	6	CO4
18(a)	Describe the preventive measures to control saltwater intrusion into coastal aquifers with neat sketches.	7	CO4
18(b)	By conductivity measurements in a well in a coastal aquifer extending 4 km along the shore, the interface was located at a depth of 20 m below m.s.l. at 100 m from the shore, inland. The depth of the homogenous aquifer is 30 m below m.s.l. and has a permeability of 50 m/day. What is the rate of fresh water flow into the sea and the width of gap at the shore bottom through which it escapes into the sea? What is the position of the toe of the saltwater wedge? Use Glover's method.	7	CO4
<b>Module V</b>			
19 (a)	Explain different techniques of artificial recharge of ground water with neat sketches.	8	CO5
19 (b)	Find the numerical value of the third and fourth order aquifer head gradient by the forward, backward and	6	CO5

	central difference method assuming uniform head distribution in a confined aquifer between two wells located 4 Km apart with piezometric levels of 100 m and 102 m respectively. Take these two wells as the extreme nodes.		
20 (a)	One dimensional steady state flow is happening in a confined aquifer with transmissivity T. The aquifer is bounded by an impervious boundary to the left and a constant head boundary to the right. Ground water flows into the aquifer due to a constant recharge Q through an aquitard. Assuming $Q=0.0005\text{m/day}$ , $T=500\text{ m/day}$ , thickness of aquifer $b=100\text{m}$ , length of aquifer $L=5\text{ Km}$ , Constant head of right boundary $H=100\text{ m}$ , find the head at different nodes using central difference scheme.(Take discretization interval as 1250 m)	10	CO5
20 (b)	Write any six applications of ground water models.	4	CO5





**Model Question Paper****Pages: 3**

Reg No.:.....

**QP**

CODE:.....

Name:.....

**APJ ABDUL KALAM TECHNOLOGICAL UNIVERSITY  
FIFTH SEMESTER B.TECH DEGREE EXAMINATION, MONTH & YEAR**

**Course Code: CET 397****Ground Water Hydrology****Max. Marks: 100  
hours****Duration: 3****Part A****(Answer all questions; each question carries 3 marks)**

1. Explain different properties of aquifer
2. What is an infiltration gallery? Explain with figure.
3. Briefly explain Theis method of estimation of aquifer parameters
4. What are the assumptions in the derivation of partial differential equation of unsteady radial flow towards wells?
5. Find the number of image wells and locate the image wells when the aquifer is delimited by two converging recharge boundaries at right angles.
6. What are the applications of electrical resistivity method?
7. What are the different sources of pollution of ground water? Explain briefly
8. Explain upconing with neat sketch
9. Write the equations for the second order head gradient of an aquifer using central, forward and backward difference schemes
10. Write the governing equations of groundwater flow and boundary conditions

**Part B****(Answer one full question from each module, each question carries 14 marks)****Module I**

- 11 (a) Explain different types of aquifer with neat sketches (7 Marks)
- (b) In a field test, time of 6 hour was required for a tracer to travel between two observation wells 42 m apart. If the difference in water-table elevations in these wells were 0.85 m and the porosity of the aquifer is 20%, calculate the coefficient of permeability of the aquifer. (7 Marks)

OR

- 12.(a) State Darcy's law and its limitations (4 Marks)
- (b) Sketch a typical infiltration gallery. Derive the equation for discharge per unit length of the infiltration gallery and phreatic surface by making suitable assumptions. (10 Marks)

**Module II**

- 13(a) Derive partial differential equation for unsteady ground water flow (10 Marks)
- (b) A well of 30 cm diameter is located in a confined aquifer of transmissibility  $500\text{m}^2/\text{day}$  and storage coefficient of 0.005. What pumping rate will have to be adopted if the drawdown at the well is not to exceed 10 m in 2 days. (4 Marks)

OR

- 14.(a) The time drawdown data recorded at an observation well situated at a distance of 50 m from the pumping well is given below.

Time (min)	Drawdown (m)
1.5	0.15
3	0.6
4.4	1
6	1.4
10	2.4
20	3.7
40	5.1
100	6.9

If the well discharge is  $1.8\text{ m}^3/\text{min}$ , calculate the transmissibility and storage coefficient of the aquifer using modified Theis method. (9 Marks)

(b) Describe the method for the estimation of aquifer parameters by Chow's method.

(5 Marks)

### Module III

15. (a) Describe the seismic refraction method for groundwater investigation with a neat sketch. (7 Marks)

(b) An aquifer is delineated by two converging barrier boundaries, the angle of wedge being  $45^\circ$ . Compute the number of image wells associated with the wedge shaped boundary system and mark them neatly in a sketch. (7 Marks)

OR

16. (a) In a seismic refraction survey for locating an aquifer, slopes of  $1.66 \times 10^{-3}$  and  $0.000625$  s/m were noted from the time-distance plots. If the cross-over distance is  $20.76$  m, compute the depth to the aquifer, the critical shot-geophone distance, and the correct angle of incidence for the refraction along the interface. (5 Marks)

(b) A  $30\text{cm}$  well is pumped at the rate of  $1000$  lpm. The transmissibility of the aquifer is  $0.015\text{m}^2/\text{s}$ . If the well is located at a distance of  $120\text{m}$  from a stream, what should be the drawdown

(i) In the pumping well

(ii) In an observation well  $100\text{m}$  away from the pumping well on the side opposite to the stream

(iii) In an observation well  $85\text{m}$  away from the pumping well, on a line parallel to the stream. (9 Marks)

### Module IV

17 (a) Derive the relationship between length of interface and freshwater discharge in a confined aquifer. (8 Marks)

(b) Explain different water quality plots with neat sketches. (6 Marks)

OR

18 (a) Describe the preventive measures to control saltwater intrusion into coastal aquifers with neat sketches. (7 Marks)

- (b) By conductivity measurements in a well in a coastal aquifer extending 4 km along the shore, the interface was located at a depth of 20 m below m.s.l. at 100 m from the shore, inland. The depth of the homogenous aquifer is 30 m below m.s.l. and has a permeability of 50 m/day. What is the rate of fresh water flow into the sea and the width of gap at the shore bottom through which it escapes into the sea? What is the position of the toe of the saltwater wedge? Use Glover's method. (7 Marks)

**Module V**

- 19 (a) Explain different techniques of artificial recharge of ground water with neat sketches. (8 Marks)
- (b) Find the numerical value of the third and fourth order aquifer head gradient by the forward, backward and central difference method assuming uniform head distribution in a confined aquifer between two wells located 4 Km apart with piezometric levels of 100 m and 102 m respectively. Take these two wells as the extreme nodes. (6 Marks)

**OR**

- 20.(a) One dimensional steady state flow is happening in a confined aquifer with transmissivity  $T$ . The aquifer is bounded by an impervious boundary to the left and a constant head boundary to the right. Ground water flows into the aquifer due to a constant recharge  $Q$  through an aquitard. Assuming  $Q=0.0005\text{m/day}$ ,  $T= 500 \text{ m/day}$ , thickness of aquifer  $b=100\text{m}$ , length of aquifer  $L= 5 \text{ Km}$ , Constant head of right boundary  $H=100 \text{ m}$ , find the head at different nodes using central difference scheme.(Take discretization interval as 1250 m) (10 Marks)
- (b) Write any six applications of ground water models. (4 Marks)

APJ ABDUL KALAM  
TECHNOLOGICAL  
UNIVERSITY

# SEMESTER VI

KTU



## CIVIL ENGINEERING

### CORE COURSES – S6

SLOT	COURSE NO.	COURSES	L-T-P	HOURS	CREDIT
A	CET302	STRUCTURAL ANALYSIS – II	3-1-0	4	4
B	CET304	ENVIRONMENTAL ENGINEERING	4-0-0	4	4
C	CET306	DESIGN OF HYDRAULIC STRUCTURES	4-0-0	4	4
D	CETXXX	PROGRAM ELECTIVE I	3-0-0	3	3
E	HUT300	INDUSTRIAL ECONOMICS & FOREIGN TRADE	3-0-0	3	3
F	CET308	COMPREHENSIVE COURSE WORK	1-0-0	1	1
S	CEL332	TRANSPORTATION ENGINEERING LAB	0-0-3	3	2
T	CEL334	CIVIL ENGINEERING SOFTWARE LAB	0-0-3	3	2
R/M/H	VAC	REMEDIAL/MINOR/HONOURS COURSE	3-1-0	4*	4
TOTAL				25/29	23/27

### MINOR COURSES - S6

R/M/H	CET382	ESTIMATION, COSTING AND VALUATION	3-1-0	4	4
R/M/H	CET384	GEOTECHNICAL INVESTIGATION & GROUND IMPROVEMENT TECHNIQUES	3-1-0	4	4
R/M/H	CET386	ENVIRONMENTAL HEALTH & SAFETY	3-1-0	4	4

### HONOURS COURSES - S6

R/M/H	CET394	FINITE ELEMENT METHOD	3-1-0	4	4
R/M/H	CET396	EARTH DAMS AND EARTH RETAINING STRUCTURES	3-1-0	4	4
R/M/H	CET398	ENVIRONMENTAL POLLUTION MODELLING	3-1-0	4	4

### PROGRAM ELECTIVE I - S6

D	CET312	ADVANCED COMPUTATIONAL METHODS	3-0-0	3	3
	CET322	GEOTECHNICAL INVESTIGATION	3-0-0		
	CET332	TRAFFIC ENGINEERING & MANAGEMENT	3-0-0		
	CET342	MECHANICS OF FLUID FLOW	3-0-0		
	CET352	ADVANCED CONCRETE TECHNOLOGY	3-0-0		
	CET362	ENVIRONMENTAL IMPACT ASSESSMENT	3-0-0		
	CET372	FUNCTIONAL DESIGN OF BUILDINGS	3-0-0		

CET302	STRUCTURAL ANALYSIS - II	CATEGORY	L	T	P	CREDIT	Year of Introduction
		PCC	3	1	0	4	2019

**Preamble:** The course enables the students to analyse various types of multistoreyed structures using appropriate methods and tools. It utilises the procedures of force methods and displacement methods for analysing framed structures. Plastic theory and its applications are introduced to students. A very important topic of applications of principles of dynamics to analyse structures while undergoing dynamic deformations is also made familiar with. The course trains the students to develop mathematical models and helps to sharpen their analytical skills, which also helps the student to lay foundation for further advanced topics like finite element method.

**Prerequisite:** CET301 Structural Analysis I

**Course Outcomes:** After the completion of the course the student will be able to

Course Outcome	Description of Course Outcome	Prescribed learning level
CO1	Understand the principles of plastic theory and its applications in structural analysis.	Understanding, Applying
CO2	Examine the type of structure and decide on the method of analysis.	Analysing, Applying
CO3	Apply approximate methods of analysis for framed structures to ascertain stress resultants approximately but quickly.	Analysing, Applying
CO4	Apply the force method to analyse framed structures.	Understanding,Analysing, Applying
CO5	Apply the displacement methods to analyse framed structures.	Understanding, Analysing, Applying
CO6	Remember basic dynamics, understand the basic principles of structural dynamics and apply the same to simple structures.	Remembering, Understanding, Applying

### Mapping of course outcomes with program outcomes (Minimum requirement)

	PO1	PO2	PO3	PO4	PO5	PO6	PO7	PO8	PO9	PO10	PO11	PO12
CO1	3	2	-	-	-	-	-	-	-	-	-	-
CO2	3	3	2	-	-	-	-	-	-	-	-	-
CO3	3	3	1	-	-	-	-	-	-	-	-	-
CO4	3	3	1	-	-	-	-	-	-	-	-	-
CO5	3	3	1	-	-	-	-	-	-	-	-	-
CO6	3	3	1	-	-	-	-	-	-	-	-	-

### Assessment Pattern

Bloom's Category	Continuous Assessment Tests		End Semester Examination
	1	2	
Remember	05	05	10
Understand	10	10	20
Apply	20	20	50
Analyse	15	15	20
Evaluate			
Create			

### Mark distribution

Total Marks	CIE	ESE	ESE Duration
150	50	100	3 hours

### Continuous Internal Evaluation Pattern:

Attendance : 10 marks  
 Continuous Assessment Test (2 numbers) : 25 marks  
 Assignment/Quiz/Course project : 15 marks

**End Semester Examination Pattern:** There will be two parts; Part A and Part B. Part A contain 10 questions with 2 questions from each module, having 3 marks for each question. Students should answer all questions. Part B contains 2 questions from each module of which student should answer any one. Each question carries 14 marks and can have maximum 2 sub-divisions.



## Course Level Assessment Questions

CIVIL ENGINEERING

<b>CO1:</b>	<b>Understand the principles of plastic theory and its applications in structural analysis.</b>
1.	Derive an expression for the shape factor of a rectangular cross section.
2.	Explain the terms 'design plastic moment capacity of a member' and 'collapse load of a structure'
3.	Find the plastic moment capacity of the beam shown in figure. Assume uniform section throughout.
4.	For the cantilever in Fig.2, determine the collapse load.

<b>CO2:</b>	<b>Examine the type of structure and decide on the method of analysis.</b>
1.	Differentiate between force and displacement methods of analysis of framed structures.
2.	Explain how you will determine the suitability of force method or displacement method for analysis of a structure?
3.	Which are the situations in which an analyst uses approximate methods of structural analysis? What are their advantages and disadvantages?

<b>CO3:</b>	<b>Apply approximate methods of analysis for framed structures to ascertain stress resultants approximately but quickly.</b>
1.	What are the assumptions in cantilever method?
2.	Total dead load is 12 kN/m and total live load is 20 kN/m on ABCD. Analyse the frame for midspan positive moment on BC, using substitute frame method.

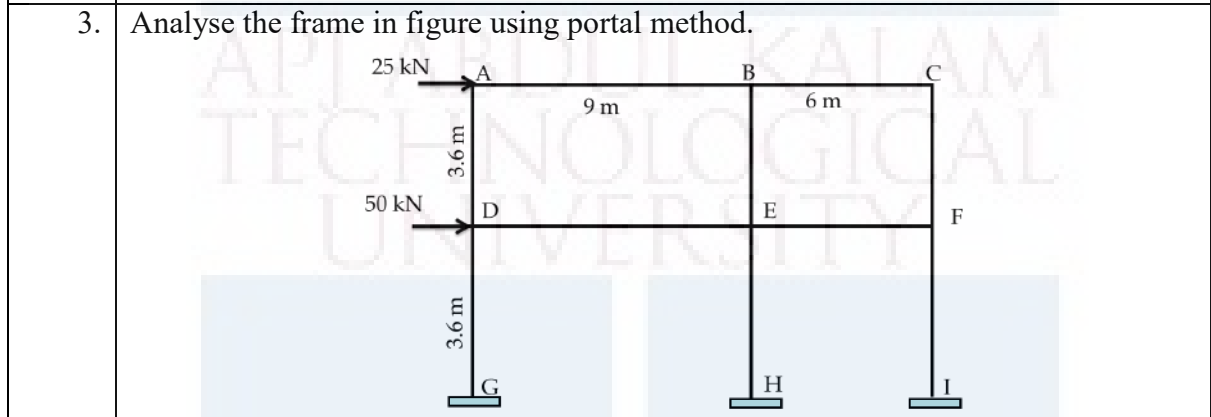
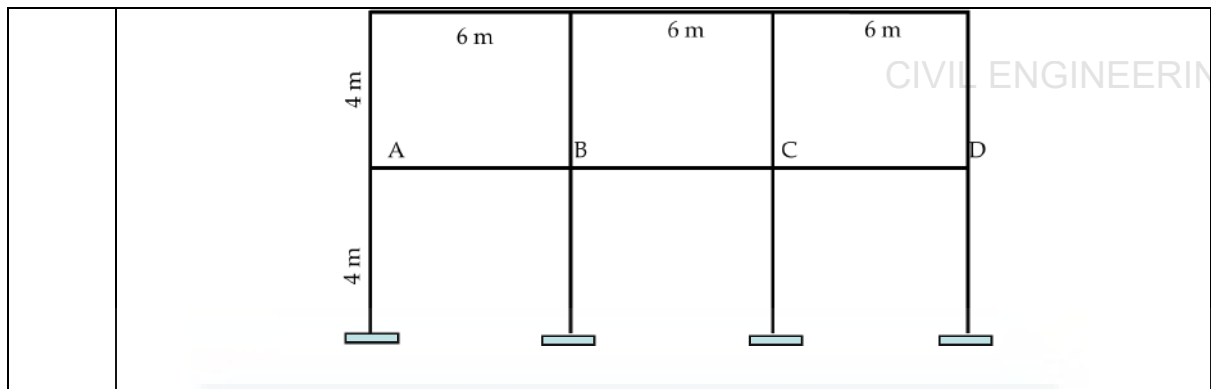

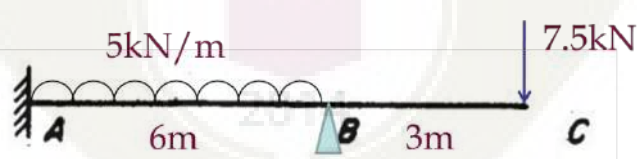
<b>CO4:</b>	<b>Apply the force method or displacement method to analyse structures accurately.</b>
1.	Derive stiffness matrix for the degrees of freedom shown for the beam in figure. 
2.	Prove that flexibility matrix is the inverse of stiffness matrix for a given set of actions and corresponding displacements.
3.	Analyse the beam in figure using flexibility method. 
4.	Determine all the member end moments for the frame shown in figure, using stiffness method.

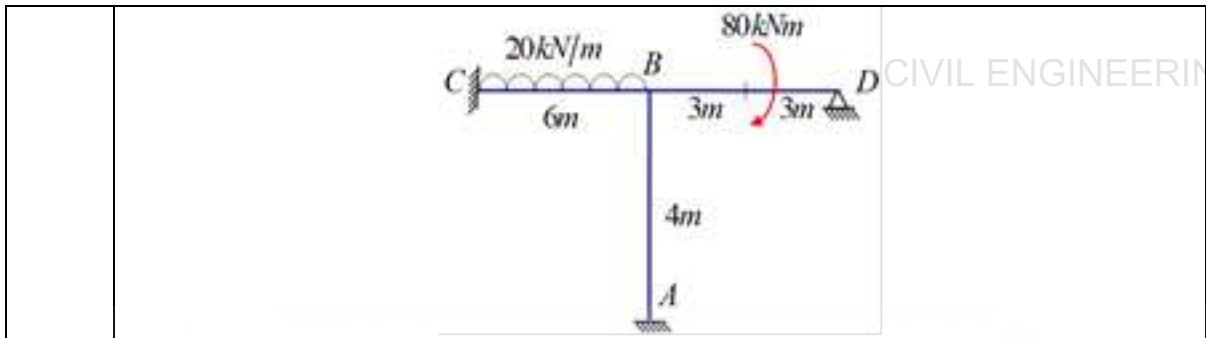

5. Determine the displacements at B for the beam shown in figure, using stiffness method.

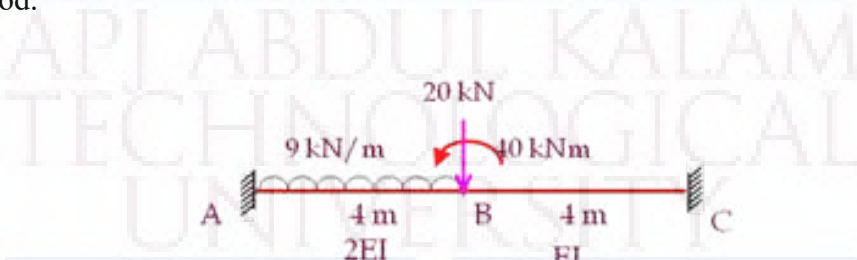

6. Find all the joint displacements for the beam in Figure 5, using direct stiffness method.

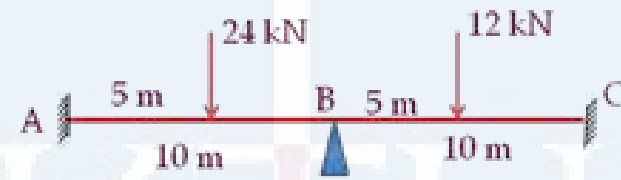

**CO5: Remember basic dynamics, understand the basic principles of structural dynamics and apply the same to simple structures.**

1. Explain the components of the basic dynamic system
2. Derive an expression for the free-vibration response of a damped SDOF system.
3. Explain transient and steady-state responses
4. A vibrating system consists of a weight of  $W = 100\text{kN}$  and a spring with stiffness  $k = 20 \text{ N/m}$  is viscously damped so that the ratio of two consecutive amplitudes is  $1/0.85$ . Determine: a) the natural frequency of the undamped system, b) the damping ratio, c) the damping coefficient and d) the damped natural frequency.

# SYLLABUS

CIVIL ENGINEERING

## MODULE I – 9 hrs.

**Plastic Theory:** Introduction – plastic hinge concepts – plastic modulus – shape factor – redistribution of moments – collapse mechanisms – Plastic analysis of beams and portal frames by equilibrium and mechanism methods.(single storey and single bay frames only) – 6 hrs.

### **Approximate methods of analysis of multistoried frames:**

Analysis for vertical loads-substitute frames-loading condition for maximum hogging and sagging moments in beams and maximum bending moment in columns – 3 hrs.

## MODULE II – 9 hrs.

Approximate methods (continued): Wind load analysis of multistoried frames – portal method and cantilever method for lateral load analysis. – 2 hrs.

### **Matrix analysis of structures:**

Definition of flexibility and stiffness influence coefficients - Concepts of physical approach – 1 hr.

*Flexibility method:* flexibility matrices for truss and frame elements-load transformation matrix-development of total flexibility matrix of the structure-analysis of simple structures-plane truss and plane frame-nodal loads and element loads-lack of fit and temperature effects. – 6 hrs.

## MODULE III – 9 hrs.

*Stiffness method:* Development of stiffness matrices by physical approach-stiffness matrices for truss and frame elements-displacement transformation matrix-analysis of simple structures-plane truss and plane frame-nodal loads and element loads-lack of fit and temperature effects. – 9 hrs.

## MODULE IV – 9 hrs.

*Direct stiffness method:* Introduction to direct stiffness method-Rotation of axes in two dimensions, stiffness matrix of elements in global co-ordinates from element co-ordinates-assembly of load vector and stiffness matrix, solution of two span continuous beam-single bay single storey portal frame. – 9 hrs.

## MODULE V

### **Structural dynamics:**

Introduction - degrees of freedom - equation of motion, D'Alembert's principle-damping-free response of damped and undamped systems- logarithmic decrement-- single degree of freedom systems subjected to harmonic load - transient and steady state responses, simple portal frame problems. – 9 hrs.

**Text Books:**

1. James M Gere & William Weaver, Matrix Analysis of Framed Structures - (CBS Publishers)
2. Mechanics of Structures Vol I & II, Junnarkar S.B., Charotar Publishing House
3. Devdas Menon, Structural Analysis, Narosa Publications
4. Wang C.K., Intermediate Structural Analysis, McGraw Hill
5. Mario Paz, Structural Dynamics

**References:**

1. Pandit and Gupta, Structural Analysis – A Matrix Approach
2. Reddy C. S., Basic Structural Analysis, Tata McGraw Hill
3. Norris and Wilbur, Elementary Structural Analysis, Tata McGraw Hill
4. Punmia B. C., Strength of Materials and Mechanics of Structures, Laxmi Publications
5. RC Hibbeler, Structural Analysis
6. Wang C K, Matrix Method of Structural Analysis
7. Anil. K. Chopra, Dynamics of structures, Pearson Education/ Prentice Hall India,
8. Clough R.W. and Penzein, J., Dynamics of structures - Tata McGraw Hill
9. Madhujith Mukhopadhyay and Abdul Hamid Sheikh, Matrix and Finite Element Analysis of Structures, Ane Books India.
10. Rajasekharan&Sankara Subramanian, Computational Structural Mechanics
11. William T Thomson, Theory of vibration with application
12. Tse, Morse Hinkle, Mechanical Vibrations

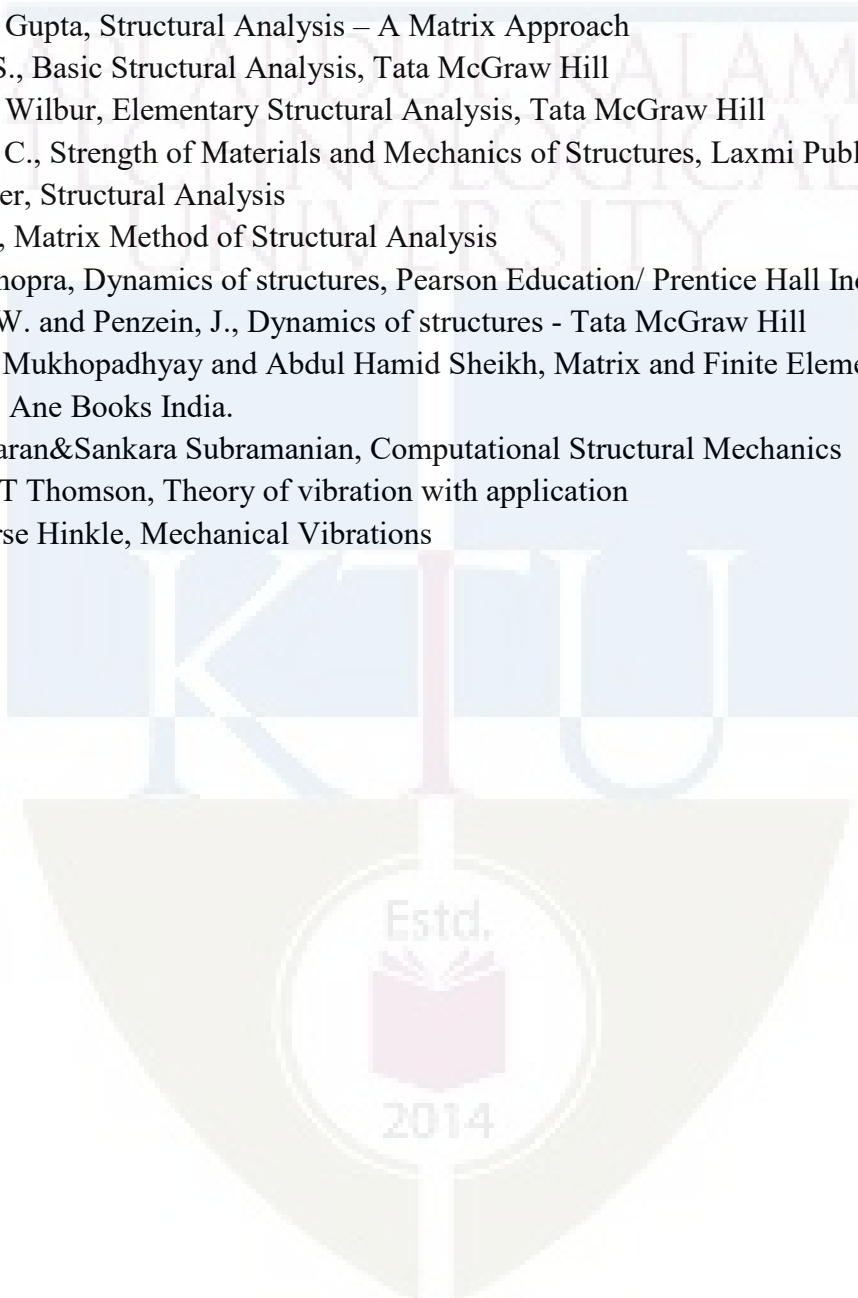

## Lecture Plan –Structural Analysis II

CIVIL ENGINEERING

Module	Topic	Course Outcomes addressed	No. of Lectures
<b>1</b>	<b>Module I: Total lecture hours: 9</b>		
1.1	Plastic Theory: Introduction – concept of plastic hinge	CO1	1
1.2	Plastic modulus – shape factor	CO1	1
1.3	Redistribution of moments – collapse mechanisms – plastic analysis of beams and portal frames by equilibrium and mechanism methods(single storey and single bay frames only)	CO1	4
1.4	Introduction to approximate methods of analysis of multistoried frames, analysis for vertical loads-substitute frames	CO2, CO3	1
1.5	Loading condition for maximum hogging and sagging moments in beams and maximum bending moment in columns – numerical problems	CO3	2
<b>2</b>	<b>Module II: Total lecture hours: 9</b>		
2.1	Approximate methods (continued): Wind load analysis of multistoried frames – portal method and cantilever method for lateral load analysis.	CO3	2
2.2	Introduction to matrix analysis of structures: Definition of flexibility and stiffness influence coefficients - Concepts of physical approach	CO2, CO4	1
2.3	Flexibility method: flexibility matrices for truss and frame elements	CO4	1
2.3	Load transformation matrix-development of total flexibility matrix of the structure	CO4	1
2.4	Analysis of simple structures-plane truss and plane frame-nodal loads and element loads	CO4	3
2.5	Lack of fit and temperature effects		1
<b>3</b>	<b>Module III: Total lecture hours: 9</b>		
3.1	Stiffness method: Development of stiffness matrices by physical approach	CO5	1
3.2	Stiffness matrices for truss and frame elements-displacement transformation matrix	CO5	2

3.3	Analysis of simple structures-plane truss and plane frame-nodal loads and element loads	CO5	5
3.4	Lack of fit and temperature effects	CO5	1
<b>4</b>	<b>Module IV: Total lecture hours: 9</b>		
4.1	Direct stiffness method: Introduction to direct stiffness method-global co-ordinates and local co-ordinates.	CO2, CO5	1
4.2	Rotation of axes in two dimensions, stiffness matrix of elements in global co-ordinates from element co-ordinates- assembly of load vector and stiffness matrix	CO5	2
4.3	Solution of numerical problems on two span continuous beam – single bay single storey portal frame	CO5	6
<b>5</b>	<b>Module V: Total lecture hours: 9</b>		
5.1	Structural dynamics: Introduction - degrees of freedom - equation of motion, D'Alembert's principle - Damping	CO6	2
5.2	Free response of damped and undamped systems	CO6	2
5.3	Logarithmic decrement	CO6	1
5.4	Single degree of freedom systems subjected to harmonic load - transient and steady state responses	CO6	2
5.5	Simple portal frame problems	CO6	2



**MODEL QUESTION PAPER**

CIVIL ENGINEERING

Reg.No.: _____		Name: _____	
<b>APJ ABDUL KALAM TECHNOLOGICAL UNIVERSITY</b>			
<b>SIXTH SEMESTER B.TECH DEGREE EXAMINATION</b>			
<b>Course Code: CET302</b>			
<b>Course Name: STRUCTURAL ANALYSIS II</b>			
Max. Marks: 100		Duration: 3 Hours	
<b>PART A</b>			
<i>Answer all questions; each question carries 3 marks.</i>			
1.	a)	Derive an expression for the shape factor of a rectangular cross section.	
	b)	What are the advantages and disadvantages of approximate methods of structural analysis?	
	c)	Derive flexibility matrix for the co-ordinates shown for the beam in figure.	
	d)	What are the assumptions in cantilever method?	
	e)	Derive stiffness matrix for the degrees of freedom shown for the beam in figure.	
	f)	Prove that flexibility matrix is the inverse of stiffness matrix for a given set of actions and corresponding displacements.	
	g)	Explain local co-ordinates and global co-ordinates.	
	h)	Write down the steps involved in direct stiffness method.	
	i)	Explain the components of the basic dynamic system.	
	j)	Explain transient and steady-state responses.	
(10×3 marks = 30 marks)			
<b>PART B</b>			
<i>Answer one full question from each module; each full question carries 14 marks.</i>			
<b>Module I</b>			
2.	Find the plastic moment capacity of the beam shown in figure. Assume uniform section throughout .		



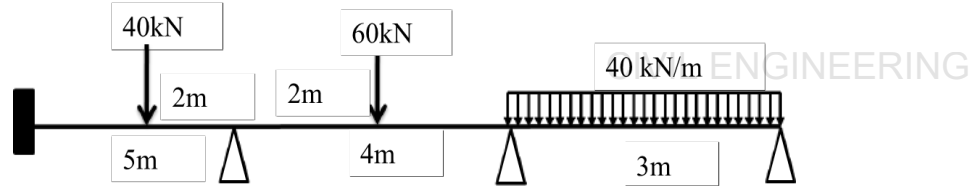

(14 marks)

3. Total dead load is 12 kN/m and total live load is 20 kN/m on ABCD. Analyse the frame for midspan positive moment on BC, using substitute frame method.

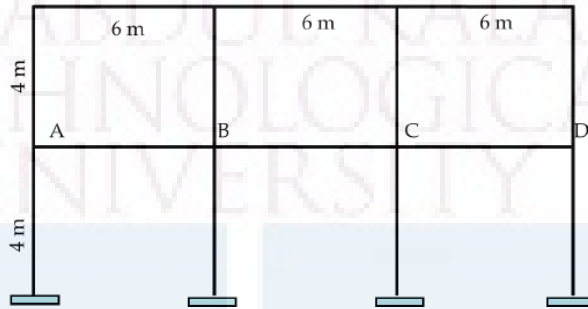

(14 marks)

### Module II

4. Analyse the beam in figure using flexibility method.

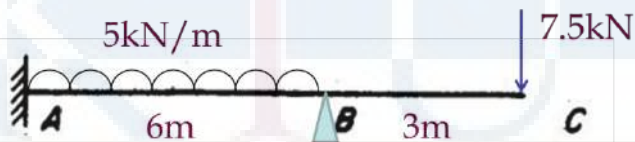

(14 marks)

5. Analyse the frame in figure using portal method.

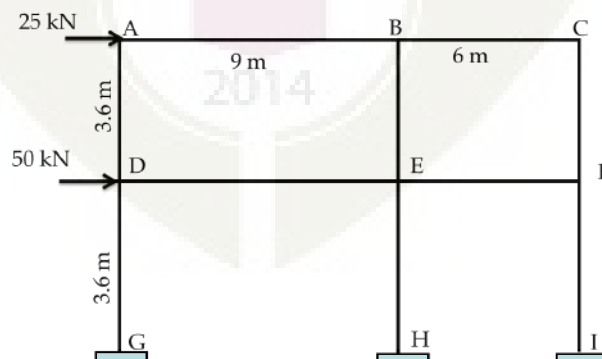

### Module III

6. Determine all the member end moments for the frame shown in figure, using stiffness method.

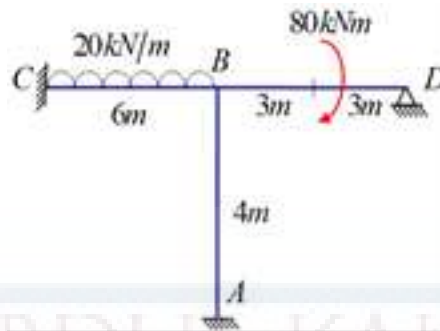

(14 marks)

7. Determine the displacements at B for the beam shown in figure, using stiffness method.

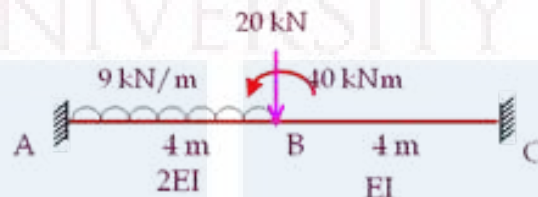

(14 marks)

#### Module IV

8. Find all the joint displacements for the beam in Figure 5, using direct stiffness method.

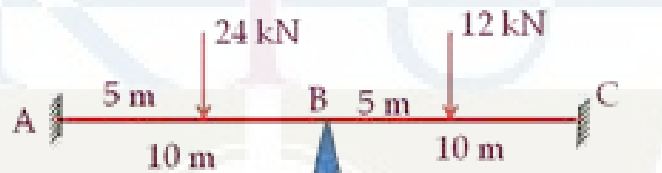

(14 marks)

9. Find the joint displacements for the pin-jointed truss shown in figure, using direct stiffness method.

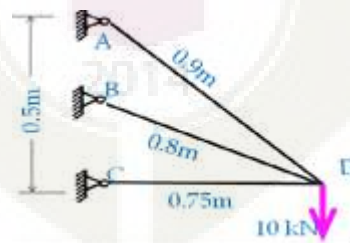

(14 marks)

#### Module V

10.	Derive an expression for the free-vibration response of a damped SDOF system (Underdamped case only). (14 marks)	CIVIL ENGINEERING
11.	A vibrating system consists of a weight of $W = 100\text{kN}$ and a spring with stiffness $k = 20\text{ N/m}$ is viscously damped so that the ratio of two consecutive amplitudes is $1/0.85$ . Determine: a) the natural frequency of the undamped system, b) the damping ratio, c) the damping coefficient and d) the damped natural frequency (14 marks)	
*****		

API ABDUL KALAM  
TECHNOLOGICAL  
UNIVERSITY

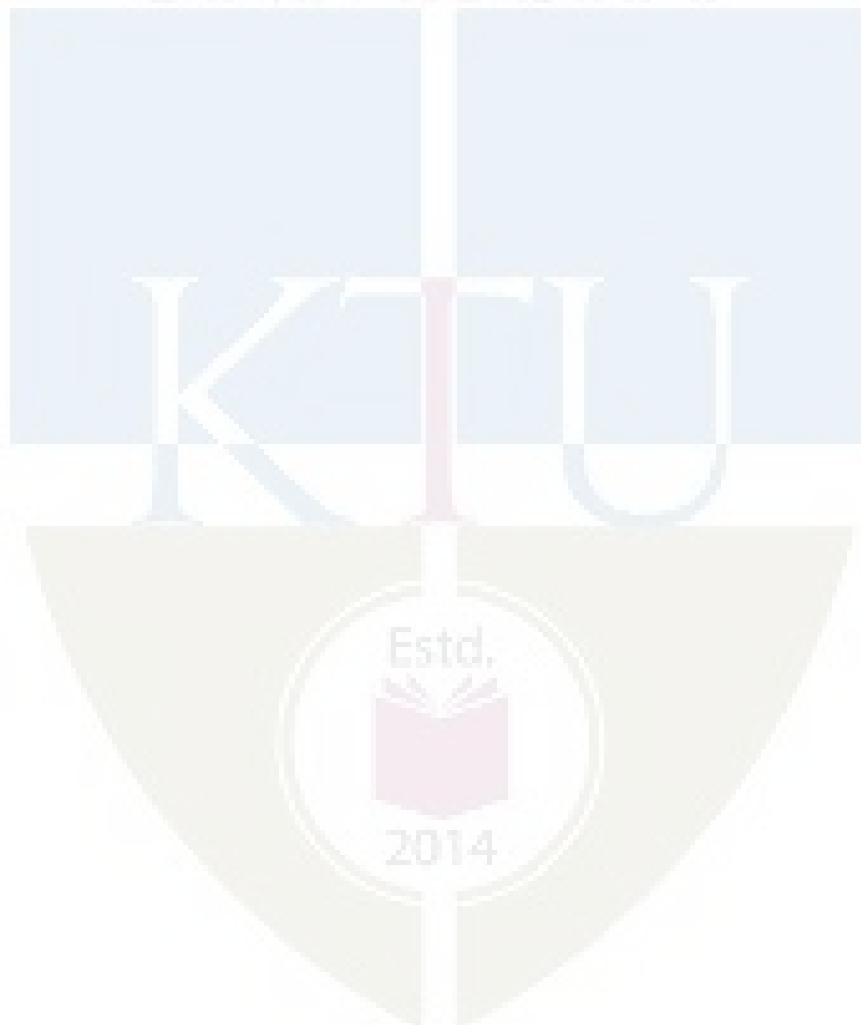



**Assessment Pattern**

Bloom's Category	Continuous Assessment Tests		End Semester Examination
	1	2	
Remember	10	10	15
Understand	10	10	15
Apply	15	15	35
Analyse	15	15	35
Evaluate			
Create			

**Mark distribution**

Total Marks	CIE	ESE	ESE Duration
150	50	100	3 hours

**Continuous Internal Evaluation Pattern:**

Attendance : 10 marks  
 Continuous Assessment Test (2 numbers) : 25 marks  
 Assignment/Quiz/Course project : 15 marks

**End Semester Examination Pattern:** There will be two parts; Part A and Part B. Part A contain 10 questions with 2 questions from each module, having 3 marks for each question. Students should answer all questions. Part B contains 2 questions from each module of which student should answer any one. Each question carries 14 marks and can have maximum 2 sub-divisions.

**Course Level Assessment Questions****CO1: To be able to appreciate the role of environmental engineering in improving the quality of environment**

1. Explain from a health perspective the need for treating drinking water and safe disposal of waste water
2. How to dispose the sludge from waste water treatment plant safely?
3. How to remove colloidal range particles from water to satisfy drinking water norms?

**CO 2: To be able to plan for collection and conveyance of water and waste water**

1. How design period is decided for water supply schemes?
2. Discuss various types of pumps used in a water supply scheme
3. Compare separate and combined sewerage systems

**CO3: To be able to enhance natural water purification processes in an engineered environment**

1. Discuss different types of aerators with their advantage and limitations
2. Design a continuous flow rectangular sedimentation tank for a population of 20,000 persons with an average per capita demand of 120 litres per day. Assume a detention period of 6 hours.
3. Design an activated sludge plant to treat 6.0 Mld of sewage with BOD of 210 mg/l. The final effluent should be 30 mg/l

**CO4: To be able to decide on appropriate technology for water and waste water treatment**

1. Compare aerobic and anaerobic biological processes for treating waste water
2. Explain in detail the different disinfection techniques available for water and waste water treatment?
3. Discuss the treatment method available for high strength waste water

**SYLLABUS****Module 1**

Introduction to environmental engineering and role of environmental engineers-enhancing natural purification processes in an engineered environment-public health perspective for treating water and waste water - 1hr

Water quantity estimation:

Population forecast- water demand estimation-types of demand- demand fluctuation -3 hrs

Estimation for waste water quantity:

Dry weather flow and storm water flow-population equivalent-design period - 2 hrs

Collection and conveyance:

water intake structures- -gravity flow and pressure flow systems- 1 hr

Systems of sewerage: separate and combined-types of pumps for water and waste water conveyance - 2 hrs

**Module 2**

Layout plan of a conventional water treatment plant- site selection-concept of unit operations and unit processes-Screening-types of screens -aeration -aerator types- 3 hrs

Theory and principles of sedimentation-Stoke's law-Types of settling -Design of plain sedimentation tanks - 4 hrs

Mechanisms of coagulation and flocculation, popular coagulants and feeding devices -2 hrs

**Module 3**

Filtration of water-theory of filtration-types of filters - design of arapid sand filter - 3hrs

Disinfection of water - various methods - advantages and limitations -2 hrs

Lay out of water distribution network-types-methods of distribution-network analysis -Hardy cross and equivalent pipe methods-4 hrs

**Module 4**

Layout plan of a conventional waste water treatment plant- site selection- concept of primary, secondary and tertiary treatment- 1hr

Unit operations in waste water- primary treatment -equalization of flow- 2hrs

Secondary treatment methods-basic concepts of biological unit processes-aerobic and anaerobic- attached and suspended growth processes (Concepts only)- 2 hr

Activated sludge process- basic concepts-design of a conventional Activated Sludge Plant - 3hrs

Trickling filter (Concept only)- types- construction & operation - 1 hr

### Module 5

Anaerobic treatment of high strength waste water- Up flow Anaerobic Sludge Blanket (UASB) reactor (Concept only)- 2 hrs

Natural waste water treatment systems-Oxidation Ponds and Lagoons-Wetlands and Root-zone systems ( Concepts only)- 3 hrs

Low cost sanitation systems- Design of a septic tank and soak-pit - 2 hr

Sludge treatment (concepts only) -thickening- digestion- dewatering- drying- composting- 2hrs

### Text Books:

1. Howard S Peavy, Donald R Rowe and George Tchobanoglous, Environmental Engineering, Mc Graw Hill Education , 2013
2. Mackenzie L Davis, David A Cornwell, Introduction to Environmental Engineering, Mc Graw Hill Education, 2014
3. S.K.Garg, Water Supply Engineering, Khanna Publishers. 2010
4. G S Birdie, Water Supply and Engineering, Dhanapat Rai Publishing Company, 2014
5. J. Arceivala, Shyam R. Asolekar, Wastewater Treatment for Pollution Control and Reuse, McGrawhill Education, 2007
6. S.K. Garg, Sewage disposal and air pollution engineering, Khanna Publishers. 2008

### References:

1. Metcalf and Eddy, Waste Water Engineering, Tata McGraw Hill publishing Co Ltd, 2003
2. Syed R Qasim, Edward M Motley, Guang Zhu, Water Works Engineering-Planning, Design & Operation, PHI Learning, 2012.
3. Syed R Qasim, Wastewater Treatment Plants-Planning, Design & Operation, CRC Press,1999



**Lecture Plan- Environmental Engineering**

<b>Module</b>	<b>Topic</b>	<b>Course Outcomes addressed</b>	<b>No. of Lectures</b>
<b>1</b>	<b>Module 1: Total Lecture Hours -9</b>		
1.1	Introduction to environmental engineering and role of environmental engineers-enhancing natural purification processes in an engineered environment-public health perspective for treating water and waste water	CO1	1
1.2	Water and waste water quantity estimation: Population forecast- water demand estimation-types of demand- demand fluctuation	CO2	3
1.3	Estimation for waste water quantity- dry weather flow and storm water flow-population equivalent-design period	CO2	2
1.4	Collection and conveyance: water intake structures- -gravity flow and pressure flow systems-	CO2	1
1.5	Systems of sewerage: separate and combined-types of pumps for water and waste water conveyance	CO2	2
<b>2</b>	<b>Module II: Total Lecture Hours- 9</b>		
2.1	Layout plan of a conventional water treatment plant- site selection-concept of unit operations and unit processes- Screening-types of screens-aeration-aerator types	CO1,CO4	3
2.2	Theory and principles of sedimentation-Stoke's law- Types of settling -Design of plain sedimentation tanks	CO3	4
2.3	Mechanisms of coagulation and flocculation, popular coagulants and feeding devices	CO3	2
<b>3</b>	<b>Module III: Total Lecture Hours-9</b>		
3.1	Filtration of water-theory of filtration-types of filters - design of rapid sand filter	CO3,CO4	3
3.2	Disinfection of water - various methods - advantages and limitations	CO4	2
3.3	Lay out of water distribution network-methods of distribution-network analysis -Hardy cross and equivalent pipe methods	CO4	4
<b>4</b>	<b>Module IV: Total Lecture Hours- 9</b>		

4.1	Layout plan of a conventional waste water treatment plant- site selection- concept of primary, secondary and tertiary treatment	CO1	1
4.2	Unit operations in waste water- primary treatment - equalization of flow	CO3	2
4.3	Secondary treatment methods- basic concepts of biological unit processes-aerobic and anaerobic- attached and suspended growth processes (Concepts only)	CO4	2
4.4	Activated sludge process- basic concepts-design of a conventional Activated Sludge Plant	CO3	3
4.5	Trickling filter (Concept only)- types- construction & operation	CO3	1
<b>5</b>	<b>Module V: Total Lecture Hours- 9</b>		
5.1	Anaerobic treatment of high strength waste water- Up flow Anaerobic Sludge Blanket (UASB) reactor (Concept only)	CO3	2
5.2	Natural waste water treatment systems-Oxidation Ponds and Lagoons-Wetlands and Root-zone systems (Concepts only)	CO3, CO4	3
5.3	Low cost sanitation systems- Design of a septic tank and soak-pit	CO3	2
5.4	Sludge treatment (concepts only) - thickening- digestion- dewatering- drying- composting	CO4	2



**Model Question Paper**

Reg No.: \_\_\_\_\_

Name: \_\_\_\_\_

**APJ ABDUL KALAM TECHNOLOGICAL UNIVERSITY  
SIXTH SEMESTER B.TECH DEGREE EXAMINATION****Course Code: CET304****Course Name: ENVIRONMENTAL ENGINEERING**

Max. Marks: 100

Duration: 3 Hours

**Part A***(Answer all questions; each question carries 3 marks)*

1. Explain dry weather flow
2. What is an intake?
3. Why screens are used in water and waste water treatment plants?
4. What is hindered settling?
5. Compare slow sand filter and rapid sand filter
6. Explain the principle of disinfection
7. Discuss the unit operations and unit processes in a waste water treatment plant
8. Compare aerobic and anaerobic processes
9. How wetlands treat waste water?
10. Explain the working of a septic tank with a neat sketch

**PART B***(Answer one full question from each module, each question carries 14 marks)*

11. (a) Explain in brief different methods used for prediction of future population of a city (9 Marks)  
(b) What is fire demand? How will you calculate fire demand (5 Marks)
- OR
12. (a) Explain the term "Design Period" (5 Marks)  
(b) Forecast the population of the town in the year 2040 from the following data using arithmetic increase method and geometric increase method

Year	1990	2000	2010	2020
Population	13400	19500	28500	36300

(9 Marks)

13. (a) Explain with sketches the types of aerators with advantages and limitations (6 Marks)  
 (b) Explain different types of settling (8Marks)
- OR
14. (a) Explain the mechanisms of coagulation (5 Marks)  
 (b) Design a plain sedimentation tank for treating 6 MLD of water. Make suitable assumption. Prepare a neat sketch (9 Marks)
15. (a) Explain the theory of filtration (5 Marks)  
 (b) Explain and compare various disinfection methods (9Marks)
- OR
16. Design a rapid sand filter to treat 10 million litres of raw water per day allowing 0.5% of filtered water for backwashing. Half hour per day is used for backwashing. Assume necessary data. (14 Marks)
17. (a) Discuss the role of an equalization tank at a waste water treatment plant (4Marks)  
 (b) Discuss in detail various biological processes available for treating waste water (10 marks)
- OR
18. (a) Explain primary, secondary and tertiary treatment phases (5 Marks)  
 (b) Design an activated sludge plant treat 6.0 Mld of domestic sewage having a BOD of 210 mg/l. The final effluent should have a BOD of 30 mg/l. (9 Marks)
19. (a) Discuss sludge treatment processes for safe disposal (9 Marks)  
 (b) Explain the working of a UASB with neat sketch (5 Marks)
- OR
20. Discuss natural waste water treatment systems with neat sketches (14 Marks)

<b>CET306</b>	<b>DESIGN OF HYDRAULIC STRUCTURES</b>	<b>Category</b>	<b>L</b>	<b>T</b>	<b>P</b>	<b>Credit</b>	<b>Year of Introduction</b>
		<b>PCC</b>	<b>4</b>	<b>0</b>	<b>0</b>	<b>4</b>	<b>2019</b>

**Preamble:**

The general objective of this course is to expose the students to the fundamental concepts of hydraulic design of different hydraulic structures and to develop the drawings of minor irrigation structures. This course equip the students to perform the hydraulic design of minor irrigation structures such as cross drainage works, canal falls and regulators and prepare drawings of the same. To impart the knowledge on causes of failure and design criteria of hydraulic structures like dams and canal structures

**Pre-requisite:** Fluid Mechanics and Hydraulics, Hydrology & Water Resources Engineering

**Course outcome**

After the course, the student will able to:

CO1	Elucidate the causes of failure, principles of design of different components of hydraulic structures
CO2	Describe the features of canal structures and perform the design of alluvial canals
CO3	Perform the hydraulic design of minor irrigation structures such as cross drainage works, canal falls, cross regulator.
CO4	Prepare the scaled drawings of different minor irrigation structures
CO5	Describe the design principles and features of dams and perform the stability analysis of gravity dams

**CO - PO Mapping**

<b>DESIGN OF HYDRAULIC STRUCTURES</b>		PO1	PO2	PO3	PO4	PO5	PO6	PO7	PO8	PO9	PO10	PO11	PO12
	CO1	3	2					1					
	CO2		2	3									
	CO3	3	3	3									
	CO4										3		
	CO5	3	2				1	1					

**Assessment pattern**

Bloom's Category	Continuous Assessment Tests		End Semester Examination (Marks)
	Test 1 (Marks)	Test 2 (Marks)	
Remember	5	5	15
Understand	10	10	15
Apply	20	20	40
Analyze	15	15	30
Evaluate			
Create			

**Mark distribution**

Total Marks	CIE	ESE	ESE Duration
150	50	100	3 hours

**Continuous Internal Evaluation Pattern:**

Attendance	:	10 marks
Continuous Assessment Test (2 numbers)	:	25 marks
<i>(For the first internal test, minimum two designs should be included)</i>		
Assignment/Quiz/Course project	:	15 marks
<i>Assignment should be scaled drawings (in A<sub>2</sub> size sheet)</i>		
<b>Total</b>	<b>:</b>	<b>50 marks</b>

**End semester examination pattern** – There will be three parts; Part A, Part B and Part C. Part A contains 2 questions each from Modules I and II, out of which student can answer any one. Total marks for this part will be 30. Each question can have maximum 2 subdivisions and carry 15 marks. Part B will be for 50 marks with 25 mark for design and 25 mark for drawing based on Module III. In the drawing part, two views shall be asked. Part C will be for 20 Marks. Two full questions each from Modules IV and V carrying 10 mark should be asked and the student can answer any one from each module. The examination will be for 3 hours.

**Course Code: CET306**  
**Design of Hydraulic Structures**  
**Course Level Assessment Questions**

<b>CO1</b>	<b>Elucidate the causes of failure, principles of design of different components of hydraulic structures</b>
1	State Khosla's interim conclusions
2	Explain the causes of failure of weirs on permeable soils and state the remedial measures
3	Explain the corrections to be applied on % uplift pressure estimated by the method of independent variables
4.	Obtain the expression for floor thickness as per Bligh's theory

<b>CO2</b>	<b>Describe the features of canal structures and perform the design of alluvial canals</b>
1	State the functions of under-sluices and divide walls
2	Explain the classification of cross drainage structures
3	Describe the features of a Siphon well drop with a sketch
4.	Explain Kennedy's theory for the design of Alluvial channels
5.	Explain (i) level crossing (ii) canal siphon with sketches
6.	Design an irrigation canal through alluvial soils for the following data : Discharge =20 m <sup>3</sup> /sec; Lacey's silt factor =1

<b>CO3</b>	<b>Perform the hydraulic design of minor irrigation structures such as cross drainage works, canal falls, cross regulator.</b>
<b>CO4</b>	<b>Prepare the scaled drawings of different minor irrigation structures</b>
1 (a)	<b>Design a 1.5 m Sarda Type Fall for a canal carrying a discharge of 40 cumecs with the following data</b> Bed Level Upstream-105.0m Bed Level Downstream-103.5m      Side Slopes of canal-1:1 Full Supply Level Upstream-106.8 m      Bank level upstream-107.4 m Bed width-U/s and D/s-30 m      Safe Exit Gradient for Khosla's theory-1/5
(b)	Draw to a suitable scale, the following views of the structure: (a) Half sectional plan at foundation level and at top level (b) Longitudinal sectional elevation

<p>2. (a)</p>	<p>Design a 1.8 m trapezoidal notch fall for the following data:  <u>Details above drop:</u>                        Full supply discharge= 5.5 cumec                      Bed width= 5 m                      Bed level= 19.8                      Full supply depth=1.6 m                      Level at the top of the bank=22.4                      The bank top width is 1.8 m  <u>Details below drop:</u>                      Full supply discharge= 5.5 cumec                      Bed width= 5 m                      Full supply level=19.6                      Level at the top of the bank=20.6                      The bank top width is 1.8 m</p>
<p>(b)</p>	<p>Prepare the following drawings to a suitable scale                      (a) Half sectional plan at foundation level                      (b) Section along the centre line of the canal</p>

<p><b>CO5</b></p>	<p><b>Describe the design principles and features of dams and perform the stability analysis of gravity dams</b></p>
<p>1</p>	<p>Explain the features of different types of spillways</p>
<p>2</p>	<p>State the functions of Galleries and Keys in gravity dam</p>
<p>3</p>	<p>Obtain the expression for base width of elementary profile of gravity dams for no tension criteria</p>
<p>4</p>	<p>Differentiate low dams and high dams</p>
<p>4.</p>	<p>Explain the causes of failure of earth dams</p>
<p>5.</p>	<p>Enlist the design criteria of earth dams</p>
<p>6.</p>	<p>State the limitations of thin cylinder theory</p>



**Course Code: CET 306**  
**Design of Hydraulic Structures**  
**Syllabus**

**Module I**

Diversion headwork-components and functions; Weirs – types and causes of failure- Impervious floor of hydraulic structures –Bligh’s theory, Design of vertical drop weir; Design of impervious floor of hydraulic structures by Khosla’s theory

**Module II**

Canals-types, Cross section of unlined canals and alignment; Design of canals through alluvial soils- Kennedy’s theory and Lacey’s silt theory. Canal structures- cross drainage structures-types; Canal falls-Necessity, types

**Module III**

Hydraulic design and drawing of canal structures

(i) Aqueduct; (ii) Siphon Aqueduct; (iii) Canal drop (Trapezoidal Notch Fall); (iv) Sarda type fall (trapezoidal crest- impervious floor design using Khosla’s theory); (iv) Cross regulator (impervious floor design using Khosla’s theory)

**Module IV**

Dams-types; Gravity Dams-computation of forces-modes of failure and stability criteria, stability analysis. Elementary and practical profile, limiting height of gravity dams, Galleries, joints, keys, water stops, instrumentation, grouting (brief description only)

**Module V**

Earth dams-types, causes of failure and design criteria, Arch dams- thin cylinder theory; Spillways-types-Ogee spillway profile; Energy dissipation- stilling basins-Indian standard Type I and Type II (description only)

**Text Books:**

- Sathyanarayana M. C. Water Resources Engineering-Principles and Practice, New Age International Publishers. 2009
- Garg S.K., Irrigation Engineering and Hydraulic Structures, Khanna Publishers, New Delhi 2006.
- KR Arora. Irrigation, Water Resources and Water Power Engineering, S.B.H Publishers and Distributors, New Delhi. 2010.

**References:**

- Punmia B.C.Ashok K Jain, Arun K Jain, B. B. L Pande, Irrigation and Water Power Engineering. Laxmi Publications (P) Ltd 2009.
- Modi P.N. Irrigation, Water Resources and Water Power Engineering, S.B.H Publishers and Distributors, New Delhi 2009.
- Varshney, R.S. Theory & Design of Irrigation Structures -Vol III, Nem Chand & Bros., Roorkee

**Course Code: CET 306**  
**Design of Hydraulic Structures**  
**Course Plan**

Module	Topic	Course outcome addressed	No of Hours
<b>Module I (8 Hours)</b>			
1.1	Introduction to different types of Irrigation structures	CO2	1
1.2	Layout of diversion headwork- components and functions	CO2	1
1.3	Causes of failure of weirs on permeable soils and remedies	CO1	1
1.4	Bligh's theory, problem	CO1	1
1.5	Design of vertical drop weir	CO1	1
1.6	Khosla's theory-Interim conclusions and Khosla's first problem	CO1	1
1.7, 1.8	Khosla's method of independent variables- use of charts and corrections	CO1	2
<b>Module II (8 Hours)</b>			
2.1	Types of canals, alignment of canals	CO2	1
2.2	Typical cross sections of unlined canals	CO2	1
2.3	Design of channels through alluvial soils- Kennedy's theory	CO2	1
2.4, 2.5	Lacey's silt theory- problems	CO2	2
2.6	Classification of cross drainage structures	CO2	1
2.7, 2.8	Canal falls – necessity and types	CO1	2
<b>Module III (15 Hours)</b>			
3.1-3.3	Hydraulic design of Aqueduct and demonstration of drawing	CO3, CO4	3
3.4-3.6	Hydraulic design of Siphon Aqueduct and demonstration of drawing	CO3, CO4	3
3.7-3.9	Hydraulic design of Canal drop (Trapezoidal Notch Fall) and demonstration of drawing	CO3, CO4	3
3.10-	Hydraulic design of Sarda Fall with trapezoidal crest and	CO3, CO4	3

3.12	demonstration of drawing		
3.13-3.15	Hydraulic design of Cross regulator and demonstration of drawing	CO3, CO4	3
<b>Module IV (7 Hours)</b>			
4.1	Dams-Types, Computation of Forces acting on dams	CO5	1
4.2	Stability analysis- modes of failure and stability criteria of gravity dams	CO5, CO1	1
4.3	Stresses-No tension criteria, derivation of principal stress	CO5, CO1	1
4.4	Problems on stability analysis of gravity dams	CO5, CO1	1
4.5	Elementary and practical profile of gravity dams	CO5, CO1	1
4.6	Functions and types of galleries, keys and water stops etc in dams	CO5	1
4.7	Instrumentation and grouting of dams	CO5	1
<b>Module V (7 Hours)</b>			
5.1	Arch dams- types, thin cylinder theory	CO5, CO1	1
5.2	Most economical central angle of arch dam, Limitations of thin cylinder theory	CO5, CO1	1
5.3. 5.4	Earth dams, types, causes of failure and design criteria	CO5, CO1	2
5.5	Spillways- Types	CO5	1
5.6	Ogee spillway profile	CO5, CO1	1
5.7	Energy dissipation below spillways-stilling basins	CO5, CO1	1



**Model Question Paper**

Reg No.:.....

QP

CODE:.....

Name:.....

**APJ ABDUL KALAM TECHNOLOGICAL UNIVERSITY  
SIXTH SEMESTER B.TECH DEGREE EXAMINATION, MONTH & YEAR**

**Course Code: CET306**

**Design of Hydraulic Structures**

**Max. Marks: 100  
hours**

**Duration: 3**

- *Use of Khosla's chart and Blench Curves and Montague Curves are permitted in the Examination Hall*
  - *Assume suitable design data wherever necessary*

**PART A**

**(Answer one full question from each module, each question carries 15 marks)**

**Module I**

- 1 (a) State the functions of undersluices and divide walls (6 Marks)  
 (b) Explain Khosla's corrections (9 Marks)

**OR**

2. (a) State and explain Bligh's theory (5 Marks)  
 (b) Explain the causes of failure of weirs on permeable soils and state the remedial measures (10 Marks)

**Module II**

3. (a) Explain the factors to be considered in the alignment of canals (5 Marks)  
 (b) Explain the classification of cross drainage structures (10 Marks)

**OR**

4. (a) Compare Kennedy's theory and Lacey's theory. (6 Marks)  
 (b) Design an irrigation canal through alluvial soils for the following data:  
 Discharge = 20 m<sup>3</sup>/sec; Lacey's silt factor = 1 (9 Marks)

**PART B**

**(Answer any ONE full question)**

**Module III**

5. a) Design a suitable cross drainage work for the following hydraulic particulars:

(25 Marks)

**Canal**

Full supply discharge =  $50 \text{ m}^3/\text{sec}$

Full supply level=202.00

Full supply depth= 1.2 m

Bed width=36

Cross section is trapezoidal with side slope 1.5H:1V

**Drain**

High flood discharge = 450 cumecs

Bed level=199.3

High flood depth=2 m

b) Develop the drawings of:

(a) Half plan at top and half at foundation level

(15 Marks)

(b) Section along the canal

(10 Marks)

**OR**

6. a) Design a 2 m trapezoidal notch fall for the following data:

(25 Marks)

**Details above drop:**

Full supply discharge= 5.5 cumec

Bed width= 6 m Bed level= 12.00

Full supply depth=1.5 m

Level at the top of the bank=14.5

Bank top width is 3 m

**Details below drop:**

Full supply discharge= 5.5 cumec

Bed width= 6 m

Full supply level=11.5

Level at the top of the bank=12.5

Bank top width is 3 m

b) Develop the drawings of:

(a) Half sectional plan at foundation level

(15 Marks)

(b) Section along the centre line of the canal

(10 Marks)

**PART C**

(Answer one full question from each module, each question carries 10 marks)

**Module IV**

7 (a) Obtain an expression for principal stress at the toe of a gravity dam

(5 Marks)

- (b) Explain elementary profile of gravity dam. How you will develop the practical profile from it? (5 Marks)

**OR**

- 8 (a) Differentiate consolidation grouting and curtain grouting (4 Marks)
- (b) Determine the uplift force at the base of gravity dam of base width 25 m, height of water in the u/s face = 30 m, free board 3m, top width 6 m and height of water in the d/s face = 5 m. The drainage gallery is at a distance of 5 m from the u/s end. (6 Marks)

**Module V**

- 9 (a) State the limitations of thin cylinder theory (4 Marks)
- (b) Explain the classification of earth dams with sketches (6 Marks)

**OR**

- 10 (a) Explain the design features of Ogee spillways (4 Marks)
- (b) Explain the hydraulic and structural causes of failure of earth dams (6 Marks)



CET308	COMPREHENSIVE COURSE WORK	CATEGORY	L	T	P	CREDIT	Year of Introduction
		PCC	1	0	0	1	2019

**Preamble:** The course is designed to ensure that the student have firmly grasped the foundational knowledge in Civil Engineering familiar enough with the technological concepts. It provides an opportunity for the students to demonstrate their knowledge in various Civil Engineering subjects.

**Pre-requisite:** Nil

**Course outcomes:** After the course, the student will able to:

CO1	Learn to prepare for a competitive examination
CO2	Comprehend the questions in Civil Engineering field and answer them with confidence
CO3	Communicate effectively with faculty in scholarly environments
CO4	Analyze the comprehensive knowledge gained in basic courses in the field of Civil Engineering

CET 308 Comprehensive Course Work		P O	P O	P O	P O	P O	P O	P O	P O	P O	PO 10	PO 11	PO 12	PS O1	PS O2	PS O3
	CO1	3	1	1			2							1	1	
	CO2	3	1				2				3					
	CO3	3	1			1	2				3				1	
	CO4	3	3			1	2									

### Assessment pattern

Bloom's Category	End Semester Examination (Marks)
Remember	25
Understand	15
Apply	5
Analyze	5
Evaluate	
Create	

**End Semester Examination Pattern:**

A written examination will be conducted by the University at the end of the sixth semester. The written examination will be of objective type similar to the GATE examination. Syllabus for the comprehensive examination is based on following five Civil Engineering core courses.

CET 201- Mechanics of Solids

CET 203- Fluid Mechanics and Hydraulics

CET 205- Surveying & Geomatics

CET 204- Geotechnical Engineering I

CET 309- Construction Technology and Management

The written test will be of 50 marks with 50 multiple choice questions (10 questions from each module) with 4 choices of 1 mark each covering all the five core courses. There will be no negative marking. The pass minimum for this course is 25. The course should be mapped with a faculty and classes shall be arranged for practising questions based on the core courses listed above.

Written examination	:	50marks
<b>Total</b>	:	<b>50 marks</b>

**Course Level Assessment and Sample Questions:**

- Poisson's ratio for an incompressible isotropic material is:  
A) 0.25 B) 0.5 C) Zero D) Indeterminate
- The following stress-strain curve is obtained for a material. It indicates

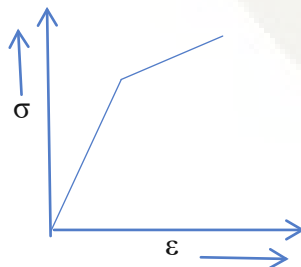

- Rigid body behaviour
- Perfectly plastic behaviour



- C) Elastic-linear strain hardening behaviour  
 D) Elastic- plastic behaviour
- 3) A principal plane is one where the shear stress will be:  
 A) Maximum B) Minimum C) Zero D) Coverage of principal stress
- 4) In a differential manometer, the flowing fluid is water and the gauge fluid is mercury. If the manometer reading is 100mm, the differential head in meters is:  
 A) 13.6 B) 1.36 C) 1.47 D) 1.26
- 5) A rectangular open channel carries a flow of  $2\text{m}^3/\text{sec}/\text{m}$ , what is the value of minimum specific energy?  
 A) 0.74m B) 1.11m C) 1.48m D) 1.85m
- 6) A pipe has diameter 0.4m, length 0.1km and coefficient of friction 0.005. What is the length of an equivalent pipe which has diameter 0.2m and coefficient of friction 0.008?  
 A) 195m B) 19.5m C) 1.95m D) 1950m
- 7) The true bearing of a line is  $40^\circ 30'$ . Declination is  $3^\circ \text{W}$ . The magnetic bearing of line is:  
 A)  $43^\circ 30'$  B)  $37^\circ 30'$  C)  $36^\circ 30'$  D)  $44^\circ 30'$
- 8) Points C and D are 1530m apart across a wide river. The following reciprocal levels are taken with one level.

Level at	Reading on	
	C	D
C	3.810 m	2.165 m
D	2.355 m	0.910 m

The true difference in elevation between C and D is:

- A) 1.645 m B) 1.545 m C) 1.745 m D) 1.345 m
- 9) Fore bearing of a line is  $540^\circ$ . Declination is  $2^\circ \text{W}$ . True bearing of line is:  
 A)  $222^\circ$  B)  $218^\circ$  C)  $S 42^\circ \text{E}$  D)  $S 38^\circ \text{E}$
- 10) The dry density of a soil is  $1.5 \text{ g/cc}$ . If the saturation water content were 50%, then its saturated density and submersed density would respectively be,  
 A)  $1.5 \text{ g/cc}$  and  $1.0 \text{ g/cc}$  B)  $2.0 \text{ g/cc}$  and  $1.0 \text{ g/cc}$  C)  $2.25 \text{ g/cc}$  and  $0.25 \text{ g/cc}$   
 D)  $2.50 \text{ g/cc}$  and  $1.50 \text{ g/cc}$

- 11) A clay sample has a void ratio of 0.50 in dry state and if the specific gravity of solids is 2.70, its shrinkage limit will be  
 A)12%            B)13.5%            C)18.5%            D)22%
- 12) A non-homogenous soil deposit consists of a silt layer sandwiched between a fine-sand layer at top and a clay layer below. Permeability of the silt layer is 10 times the permeability of the clay layer and one-tenth of the permeability of the sand layer. Thickness of the silt layer is 2 times the thickness of the sand layer and two-third of the thickness of the clay layer. The ratio of equivalent horizontal and equivalent vertical permeability of the deposit is \_\_\_\_\_.  
 A)10.967    B)10.968            C)10.969            D)None of these
- 13) Which cement contains high percentage of  $C_3S$  and less percentage of  $C_2S$ ?  
 A) Rapid Hardening Cement    B) Ordinary Portland Cement    C) Quick Setting Cement    D) Low Heat Cement
- 14) Workability of concrete is measured by \_\_\_\_\_  
 A) Vicat apparatus test    B) Slump test    C) Minimum void method    D) Talbot Richard test
- 15) The shortest possible time in which an activity can be achieved under ideal circumstances is known as \_\_\_\_\_  
 A) Pessimistic time estimate    B) Optimistic time estimate    C) Expected time estimate    D) None of these

**Course Code: CET 308**

### **Comprehensive Course Work**

#### **MODULE 1**

Concept of stress and strain, Hooke's law, Stress-strain diagram of mild steel; Axially loaded bars. Temperature stress in composite bars, Poisson's ratio, Elastic constants and the relationship between them. Beams, Concept of bending moment and shear force, Shear force and bending moment diagrams of cantilever beams, simply supported beams and overhanging beams for different type of loads. Theory of simple bending; Shear stress in beams. Principal stresses and principal planes in 2D problems, maximum shear stress; Mohr's circle .

#### **MODULE 2**

Fluid properties; Fluid statics, measurement of fluid pressure. Buoyancy and Floatation: Buoyant force, Principle of floatation, stability of floating and submerged bodies, metacentre and metacentric height; continuity equation in one, two and three dimensions. Bernoulli's equation and its applications; Pipe flow- computation of major and minor losses in pipes, equivalent pipe.

Open channel flow, velocity distribution in open channels, uniform flow computations, Most economical sections, Specific energy, Critical flow; Hydraulic jump.

### **MODULE 3**

Introduction to Surveying- Principles, Linear, angular and graphical methods. Bearing of survey lines, Local attraction, Declination; Principles of levelling, Methods of levelling. Theodolite surveying, Measurement of horizontal and vertical angle; Triangulation. Traverse Surveying, Checks in closed traverse; Theory of Errors – Types, theory of least squares, Weighting of observations. Total Station – concept of EDM, principles and working. GPS-Components and principles. Remote Sensing.

### **MODULE 4**

Definitions and properties of soil, 3 phase system, Index properties of soil, Soil classification, Effective stress, Quick sand condition, Stress distribution, Permeability of soil, Darcy's law, Factors affecting permeability, Laboratory tests, Consolidation, Normally consolidated, over consolidated and under consolidated soils, Time factor, Coefficient of consolidation, Compaction Tests – OMC and MDD, shear strength of soil, Triaxial compression test, Unconfined compression test, Direct shear test and Vane shear test

### **MODULE 5**

Cement: Manufacturing, chemical composition, Types, Tests, Hydration of cement. Properties of fresh concrete and hardened concrete. Types of stone masonry – composite walls - cavity walls and partition walls - Construction details and features. Finishing works: Plastering, Pointing, Painting – objectives and types. Prefabricated construction – advantages and disadvantages, Prefabricated building components. Causes of failures in RCC and Steel structures. Types of tenders, Types of contracts. Types of Schedules. Network analysis –CPM, PERT – concepts and problems

CEL332	TRANSPORTATION ENGINEERING LAB	CATEGORY	L	T	P	CREDIT	Year of Introduction
		PCC	0	0	3	2	2019

**Preamble:** The objective of this course is to enable students to assess the quality of various pavement materials and their suitability in highway construction. The course is designed to make student familiar with mix design and do functional evaluation of pavements.

**Prerequisite:** CET 206 Transportation Engineering I

**Course Outcomes:**

After the completion of the course the student will be able to

CO 1	Analyse the suitability of soil as a pavement subgrade material
CO 2	Assess the suitability of aggregates as a pavement construction material
CO 3	Characterize bitumen based on its properties so as to recommend it as a pavement construction material.
CO 4	Design bituminous mixes for pavement layers
CO 5	Assess functional adequacy of pavements based on roughness of pavement surface.

**Mapping of Course Outcome with Programme Outcome**

	PO1	PO2	PO3	PO4	PO5	PO6	PO7	PO8	PO9	PO10	PO11	PO12
CO1	3			2				1	2			
CO2	3			2				1	2			
CO3	3			2				1	2			2
CO4	3			2				1	2			2
CO5	3			2				1	2			2

**Course level assessment questions**

**CO1 :** Determine CBR value of the given sample of soil. Comment on its suitability as a subgrade material.

**CO2 :** Find the impact value of the given sample of aggregates. Assess its suitability as a pavement construction material based on specifications given relevant codes/guidelines.

**CO3 :** Determine softening point of the given sample of bitumen.

**CO4 :** Determine optimum binder content of the given bituminous mix by Marshall method of mix design.

**CO5 :** Determine IRI value of the given road surface using MERLIN. Comment on the condition of road surface comparing standard values.

### Assessment pattern

Bloom's Taxonomy	Continuous Internal Evaluation (CIE) (Marks)	End Semester Examination (ESE) (Marks)
Remember	10	15
Understand	10	15
Apply	40	40

### Marks Distribution

Total marks	CIE (marks)	ESE (marks)	ESE duration
150	75	75	3 hours

### Continuous Internal Assessment (CIE ) pattern

Attendance: 15 marks

Continuous Assessment: 30 marks

Internal Test: 30 marks

### End Semester examination (ESE)pattern

The following guidelines should be followed regarding award of marks

Preliminary Work: 15 marks

Conduct of Experiment: 10 marks

Tabulation of readings, Calculation, Result and Inference: 25 marks

Viva: 20 marks

Record: 5 marks

### General Instructions regarding ESE

End semester evaluation is to be conducted under the equal responsibility of both internal and external examiners. The students shall be allowed for the ESE only on submitting the duly certified record. External examiner shall endorse the record.

## Syllabus

### List of Experiments

1. Test on soil : 1 session
2. Tests on coarse aggregates : 6 sessions
3. Tests on bitumen : 4 sessions
4. Mix design of bituminous mix : 1 session
5. Functional evaluation of pavement : 1 session

### Course Content and Practical Schedule

Expt. No	List of Experiments	Course Outcome	No.of Hours
1	<b>Test on soil</b> California Bearing Ratio Test (soaked/unsaturated specimen)	<b>CO1</b>	3
2	<b>Test on Coarse Aggregate</b> Specific Gravity and Water Absorption Test	<b>CO 2</b>	3
3	Aggregate Impact Test		3
4	Los Angeles Abrasion Test		3
5	Aggregate Crushing Value Test		3
6	Shape Test (Angularity number, flakiness index, Elongation index, Combined flakiness and elongation index)		3
7	Stripping value of road aggregates		3
8	<b>Tests on Bitumen</b> Determination of grade of bitumen based on viscosity	<b>CO 3</b>	3
9	Softening point		3
10	Ductility of bitumen		3
11	Flash and fire point of bitumen		3
12	<b>Design of Bituminous Mix</b> Design of bituminous mix by Marshall method of mix design	<b>CO4</b>	3
13	<b>Functional Evaluation of Pavement</b> Use of MERLIN apparatus to determine road roughness	<b>CO5</b>	3

**\*Any twelve experiments are mandatory**

**Reference Books**

1. Khanna, S.K., Justo, C.E.G. and Veeraragavan, A., "Highway Materials and Pavement Testing", Nem Chand & Bros., Roorkee
2. G. Venkatappa Rao, K. Ramachandra Rao, Kausik Pahari and D.V. Bhavanna Rao., "Highway Material Testing and Quality Control", I.K. International.
3. L.R.Kadiyali and N.B Lal., "Principles and Practices of Highway Engineering", Khanna Publishers.

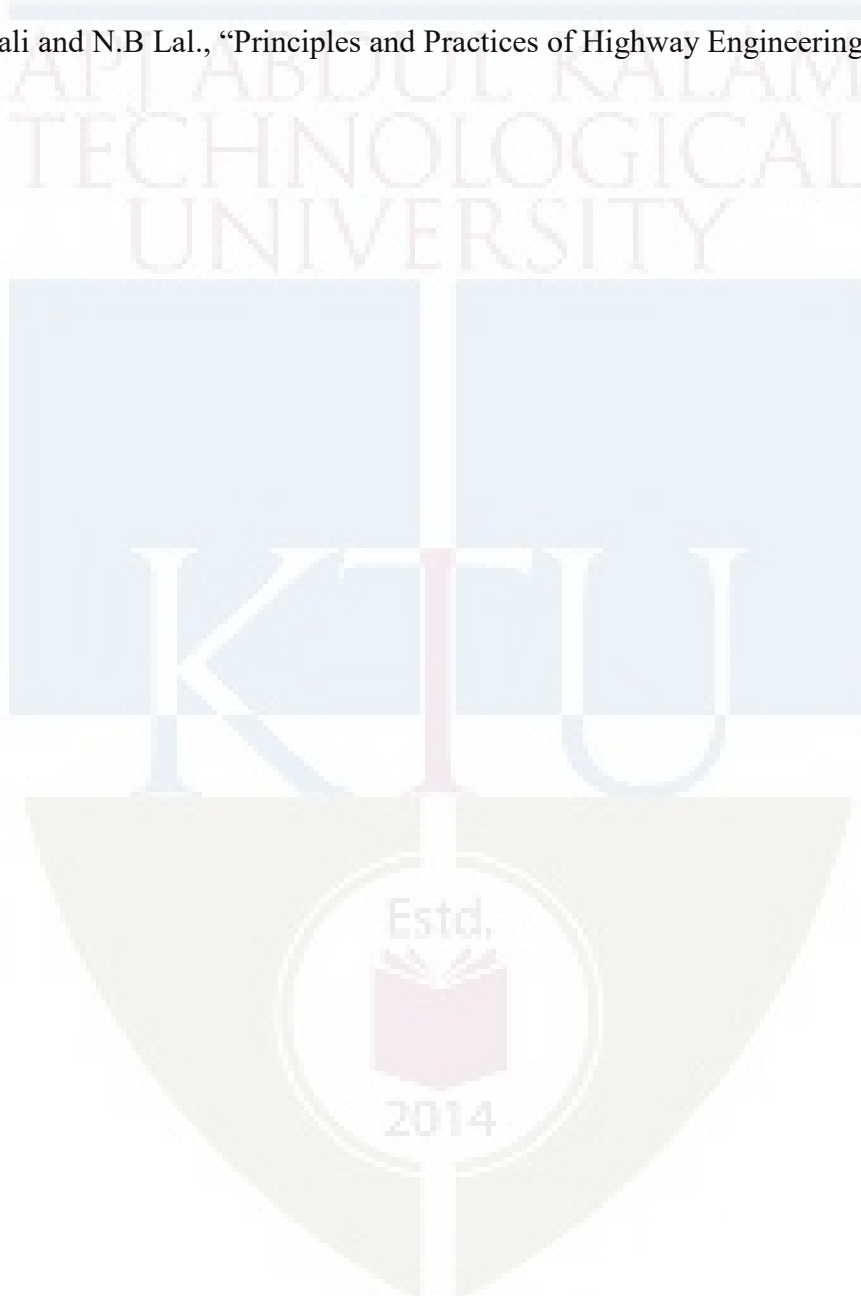

CEL 334	CIVIL ENGINEERING SOFTWARE LAB	CATEGORY	L	T	P	CREDIT	Year of Introduction
		LAB	0	0	3	2	2019

**Preamble:** The course aims to train the students to use different software tools needed for professional practice in civil engineering. Also, the field expertise needed for undertaking the surveying activity using modern instruments and hence to prepare the necessary engineering documentation are included in this laboratory course.

**Prerequisite:** Civil Engineering drawing, structural analysis and design courses, surveying lab.

**General Instructions to Faculty:**

1. All exercise listed in the syllabus need to be performed mandatorily.
2. The laboratory should have possession of required software and survey equipment for effective delivery of laboratory sessions
3. Periodic maintenance and calibration of various testing instruments needs to be made.
4. Use of data visualization packages needs to be promoted for making various plots.

**Course Outcomes:** After the completion of the course, the student will be able to:

Course Outcome	Course Outcome Description
CO 1	To undertake analysis and design of multi-storeyed framed structure, schedule a given set of project activities using a software.
CO 2	To prepare design details of different structural components, implementation plan for a project.
CO3	To prepare a technical document on engineering activities like surveying , structural design and project planning.

**Mapping of course outcomes with program outcomes:**

CO/PO	PO 1	PO 2	PO 3	PO 4	PO 5	PO 6	PO 7	PO 8	PO 9	PO 10	PO 11	PO 12
CO 1	3	2	2	2	1	3	-	-	2	2	-	2
CO 2	3	2	2	2	1	3	-	-	2	2	-	2
CO 3	3	2	2	2	1	3	-	-	2	2	-	2



**Assessment Pattern****Mark distribution**

<b>Total Marks</b>	<b>CIE</b>	<b>ESE</b>	<b>ESE Duration</b>
150	75	75	2.5 hours

**Continuous Internal Evaluation Pattern:**

Attendance	:	15 marks
Continuous Assessment	:	30 marks
Internal Test (Immediately before the second series test)	:	30 marks

**End Semester Examination Pattern:** The following guidelines should be followed regarding award of marks

(a) Preliminary work	:	15 Marks
(b) Implementing the work/Conducting the experiment	:	10 Marks
(c) Performance, result and inference (usage of equipment and troubleshooting)	:	25 Marks
(d) Viva voce	:	20 marks
(e) Record	:	5 Marks

**General instructions:**

Practical examination to be conducted immediately after the second series test and covering entire syllabus given below. Evaluation is to be conducted by both the internal and external examiners. The number of candidates evaluated per day should not exceed 20. Students shall be allowed for the University examination only on submitting the duly certified record. The external examiner shall endorse the record.

**References**

1. N Krishna Raju, Structural Design and Drawing, Second Edition, Universities Press (India), Private Limited, Hyderabad, 2009
2. Reference Manual of the Relevant Software
3. Satheesh Gopi, Dr. R Sathikumar, N Madhu, Advanced Surveying: Total Station, GIS and Remote Sensing, Pearson Education India, 2006
4. AutoCAD Essentials, Autodesk official Press, John Wiley & Sons, US, 2015

**SYLLABUS**

1. Analysis and design of steel and RCC elements using any standard software used in the industry.

Exercise 1: Analysis and design of continuous and cantilever beams

Exercise 2; Analysis and design of plane truss and frames

Exercise 3: Analysis and design of multi-storied RCC framed structures.

2. Preparation of structural drawings of slabs and beams

Exercise 4: Detailed structural drawing of one way / two way and continuous slabs.

Exercise 5: Detailed structural drawing of singly reinforced / double reinforced Beams.

Exercise 6: Detailed structural drawing of continuous / flanged beams.

Exercise 7: Detailed structural drawing of foundation units – isolated and combined footing (rectangular)

3. Use of Building Information Modelling tools

Introduction to BIM process and describe the workflow in using BIM in the building lifecycle (Theory discussion – 2 hours)

Exercise 8: Preparation of building model from a given architectural drawing of a residential unit and perform model based cost estimation

Exercise 9: Create a schedule and import it into the 4D modelling environment, so that each activity in the schedule can be linked to an object in the model.

Exercise 10: Develop schedules for the construction of slabs, walls, columns, beams and windows of a section of a residential building

Exercise 11: Effect of rescheduling the activities to complete the project in minimum time frame.

4. Use of Project Management Software (MS Project/Primavera)

Introduction to project management -CPM & PERT (Theory class-2 hours)

Exercise 12: Preparation of Bar Chart/Gantt Charts/CPM/PERT Charts

Exercise 13: To find the critical Path based on the given set of activity / event data

Exercise 14: Practice on Resource allocation and Project Monitoring (Cost and Time).

4. Field exercise to use Total Station

Exercise 15: Field exercise on preparation of contour map for a given terrain using advanced surveying instruments like Total Stations (The survey activity undertaken shall be of at least 5000 Sq. m)

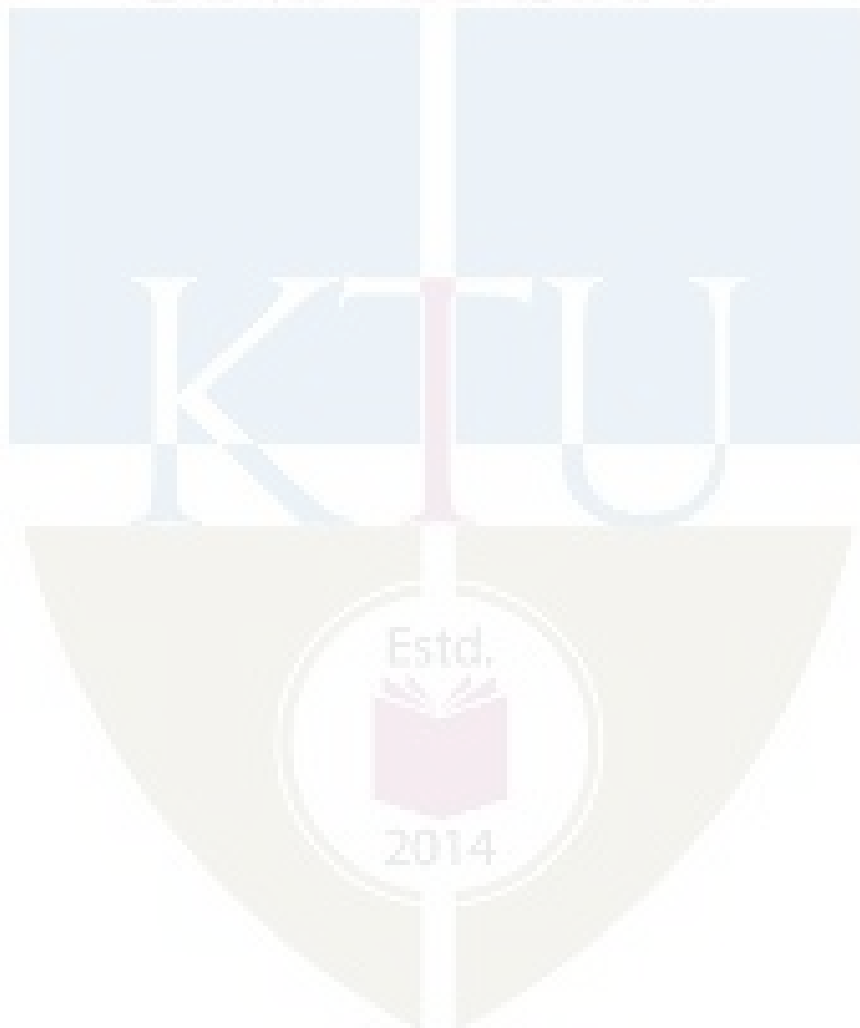

APJ ABDUL KALAM  
TECHNOLOGICAL  
UNIVERSITY

---

# **SEMESTER VI**

---

## **PROGRAM ELECTIVE I**

---





**Assessment pattern**

<b>Bloom's Category</b>	<b>Continuous Assessment Tests</b>		<b>End Semester Examination (Marks)</b>
	<b>Test 1 (Marks)</b>	<b>Test 2 (Marks)</b>	
Remember	5	5	15
Understand	10	10	15
Apply	20	20	40
Analyze	15	15	30
Evaluate			
Create			

**Continuous Internal Evaluation Pattern:**

Attendance	:	10 marks
Continuous Assessment Test(2 numbers)	:	25 marks
Assignment/Course project	:	15 marks
<b>Total</b>	:	<b>50 marks</b>

**Note:** Enough exposure to practical examples from civil engineering should be given to the students. One assignment/course project should be based on the coding of practical civil engineering problems

**End semester examination pattern** – There will be two parts; Part A and Part B. Part A contain 10 questions with 2 questions from each module, having 3 marks for each question. Students should answer all questions. Part B contains 2 questions from each module of which student should answer any one. Each question can have maximum 2 subdivisions and carry 14 marks.

**Course Level Assessment (Sample) Questions****CO1: Describe the procedures or principles of numerical computational approaches**

1. Enlist the different errors in numerical computation
2. Explain the procedure of Newton-Raphson method for solving system of non linear equations
3. Explain the procedure of multiple linear regression
4. Compare Lagrange and Hermite interpolation
5. Explain the stability of numerical solutions of ordinary differential equations
6. Explain the procedure of modified Euler's method for solving ordinary differential equations
7. Describe the classification of partial differential equations
8. Explain Crank- Nicolson implicit scheme

9. Explain collocation method
10. Describe the principle of meshless method

**CO2: Obtain the solution of simultaneous equations or eigen value problems**

1. Find all the eigen values and eigen vectors of the following matrix by Jacobi's transformation

$$A = \begin{bmatrix} 10 & 3 & 2 \\ 3 & 5 & 1 \\ 2 & 1 & 0 \end{bmatrix}$$

2. Apply Gauss Seidal iteration method to solve the equations

$$20x+y-2z=17; 3x+20y-z=-18; 2x-3y+20z=25$$

**CO3: Apply appropriate data smoothing technique for a given set of data**

1. Fit the quadratic splines with  $M(0)=0$   $f'(0)=0$  for the following data. Hence find  $f(2.5)$

$x$	0	1	2	3
$y$	1	2	33	244

2. Evaluate  $\int_0^1 \frac{1}{1+x^2} dx$  using (i) Simpson's 3/8 rule taking  $h=1/6$  (ii) Weddle's rule taking  $h=1/6$

**CO4: Obtain the numerical solutions of ordinary differential equations**

- 1 Apply Milne's method to find the solution of  $y' = x - y^2$  in the range  $0 \leq x \leq 1$  for the boundary condition
2. Using fourth order Runge-Kutta method, find  $y$  for  $z=0.1, 0.2$  and  $0.3$ , given  $y' = xy + y^2$   $y(0)=1$

**CO5: Obtain the numerical solutions for solving boundary value problems of ordinary and partial differential equations**

1. Solve  $\nabla^2 u = 10(x^2 + y^2 + 10)$  over the square with side  $x=0=y$ ;  $x=3=y$  with  $u=0$  on the boundary and mesh length =1

2. Solve  $\frac{d^4 y}{dx^4} + 81y = \phi(x)$  with

$x$	1/3	2/3	1
$y$	81	162	243

$$y(0)=y'(0)=y''(1)=y'''(1)=0$$

**CO6: Describe the concepts or apply discretization based solution methods**

- 1 Explain the procedure of weighted residual approaches for solving boundary value problems
2. Explain the different steps in Finite element analysis
3. Explain the characteristics of different types of elements in FEM
4. Solve  $y''+y+x=0$  in the range  $0 \leq x \leq 1$  by Galerkin's method. Given  $y(0)=y(1)=0$

**Course Code: CET312**

**Advanced Computational Methods**

**Syllabus**

**Module I**

Introduction to numerical methods-Errors in numerical computation – System of linear algebraic equations – Ill-conditioned systems – Symmetric and Banded systems. Elimination methods – Gauss Elimination (review), Gauss Seidel iteration, Factorization method-Choleski's method. System of non linear equations – Newton-Raphson method. Eigen value problems - largest and smallest eigen values- Power method, Jacobi's transformation

**Module II**

Lagrangian and Hermite interpolation, Spline interpolation-Quadratic and Cubic splines (example of equal intervals), Data smoothing by least squares criterion- Non- polynomial models like exponential model and power equation, Multiple linear regression. Numerical integration- Newton – Cotes open quadrature formulæ-Trapezoidal rule, Simpson's rules, Weddles rule

**Module III**

Solution of first-order ordinary differential equations-stability of solution, Use of Taylor series, Euler's method, Modified Euler's method, Predictor-corrector method – Milne's method, Fourth order Runge-Kutta method; Higher order equations of initial value type by Runge-Kutta method.

**Module IV**

Ordinary differential equations of the boundary value type – Finite difference solution.



Partial differential equations in two-dimension-types, Elliptic equations-Laplace Equation and Poisson's equation, Parabolic equations – Explicit finite difference method –Bender-Schmidt method. Crank-Nicholson implicit method, Finite difference method – Problems with irregular boundaries

### Module V

Weighted residual methods for initial value problems and boundary value problems – Collocation method, Subdomain method, Method of least squares, Galerkin's method.

Introduction to FEM- outline of the procedure – Types of 1D, 2D and 3D elements- element properties- polynomial form- shape function form- equilibrium and compatibility in the solution- convergence requirements, boundary conditions. Conceptual ideas of finite volume, boundary element and meshless methods.

### Text Books

1. Grewal B. S., *Numerical Methods for Engineers & Scientists*, Khanna Publishers.
2. Rajasekharan S., *Numerical Methods in Science and Engineering*, S Chand & Company, 2003.

### References:

1. Gerald and Wheatly, *Applied Numerical Analysis*, Pearson Education.
2. Chapra S. C. and R. P. Canale, *Numerical Methods for Engineers*, McGraw Hill, 2006.
3. Smith G. D. *Numerical solutions for Differential Equations*, McGraw Hill.
4. Ketter and Prawel, *Modern Methods for Engineering Computations*, McGraw Hill.
5. Rajasekharan S., *Numerical Methods for Initial and Boundary value problems*, Khanna Publishers, 1989.
6. Terrence. J. Akai, *Applied Numerical Methods for Engineers*, Wiley Publishers, 1994.
7. Krishnamoorthy C S, *Finite Element Analysis- Theory and Programming*, Tata McGraw Hill, New Delhi., 1994
8. Bathe K J, *Finite Element Procedures in Engineering Analysis*, Prentice Hall, New Delhi. 1982
9. Chandrupatla T R and Belegundu A D, *Introduction to Finite Elements in Engineering*, Pearson Education, New Delhi 1998
10. Rajasekharan S, *Finite Element Analysis in Engineering Design*, Wheeler, New Delhi
11. Hutton D V, *Fundamentals of Finite Element Analysis*, Tata McGraw Hill Education Private Ltd, New Delhi

**Course Plan: Advanced Computational Methods**

<b>Module</b>	<b>Topic</b>	<b>Course outcome addressed</b>	<b>No of Hours</b>
<b>Module I (7 Hours)</b>			
1.1	Introduction to numerical methods-Necessity, Errors in numerical computation	CO1	1
1.2	System of linear algebraic equations, Ill-conditioned systems, Symmetric and Banded systems	CO1	1
1.3	Direct and indirect methods of solution of linear equations- Gauss elimination method(review), Gauss Siedal iteration	CO1, CO2	1
1.4	Factorization method-Choleski's method	CO1, CO2	1
1.5	System of non linear equations – Newton-Raphson Method	CO1, CO2	1
1.6	Eigen value problems, Power method-largest & smallest Eigen values	CO1, CO2	1
1.7	Jacobi's transformation	CO1, CO2	1
<b>Module II (7 Hours)</b>			
2.1	Lagrangian and Hermite interpolation	CO1, CO3	1
2.2	Spline interpolation - Quadratic and Cubic splines	CO1, CO3	1
2.3	Problems on interpolation	CO3	1
2.4	Data smoothing by least squares criterion- Non- polynomial models like exponential model, power equation	CO1, CO3	1
2.5	Multiple linear regression	CO1, CO3	1
2.6	Numerical integration- Newton – Cotes open quadrature	CO1, CO3	1
2.7	Problems on numerical integration	CO3	1
<b>Module III (7 Hours)</b>			
3.1	Solution of first-order ordinary differential equations ; stability of solutions	CO1	1
3.2	Solution of first-order ordinary differential equations by use of Taylor series.	CO1, CO4	1
3.3	Euler's method	CO1, CO4	1
3.4	Modified Euler's method	CO1, CO4	1
3.5	Predictor-corrector methods – Milne's method	CO1, CO4	1

3.6	Fourth order Runge-Kutta method-Problems	CO1, CO4	1
3.7	Higher order equations of initial value type by Runge-Kutta method	CO1, CO4	1
<b>Module IV (7 Hours)</b>			
4.1	Ordinary differential equations of the boundary value type – Finite difference solution.	CO1, CO5	1
4.2	Partial differential equations in two-dimension- types. Laplace Equation	CO1, CO5	1
4.3	Poisson's Equation and its solution	CO1, CO5	1
4.4	Parabolic equations – Explicit finite difference method-Schmidt method	CO1, CO5	1
4.5	Crank-Nicholson implicit method	CO1	1
4.6	Finite difference method – Problems with irregular boundaries	CO1, CO5	1
4.7	Problems	CO5	1
<b>Module V (7 Hours)</b>			
5.1	Weighted residual methods for initial value problems and boundary value problems – Collocation method – Subdomain method	CO1, CO6	1
5.2	Method of least squares – Galerkin's method	CO1, CO6	1
5.3	Introduction to FEM- outline of the procedure	CO1, CO6	1
5.4	Types of 1-D, 2-D and 3-D finite elements	CO1, CO6	1
5.5	Element properties- polynomial form- shape function form	CO1, CO6	1
5.6	Equilibrium and compatibility in the solution- convergence requirements; Boundary conditions	CO1, CO6	1
5.7	General awareness on finite volume, boundary element and mesh less methods and their difference with FEM	CO1, CO6	1

**Course Code: CET312**  
**Advanced Computational Methods**  
**(Model question paper)**

Qn No	Question	Marks	Course outcome (CO) Assessed
<b>Part A</b> <b>(Answer ALL Questions)</b>			
1	Enlist the different errors in numerical computation	3	CO1
2	Explain symmetric and banded systems	3	CO1
3	Explain Hermite interpolation	3	CO1
4	Describe multiple linear regression	3	CO1
5	Explain Taylor's method for solution of differential equations	3	CO1
6	Explain stability of solutions of differential equations	3	CO1
7	Explain Crank Nicholson implicit method	3	CO1
8	State the types of partial differential equations with examples	3	CO1
9	Describe the principle of meshless method	3	CO1
10	Explain convergence requirements in finite element analysis	3	CO1
<b>Part B</b> <b>(Answer ANY ONE FULL question from each module)</b>			
<b>Module I</b>			
11	Solve by Choleski's method $\begin{bmatrix} 2 & -3 & -1 & 2 \\ -1 & -1 & 2 & -2 \\ 1 & -1 & 1 & 1 \\ 3 & 2 & -1 & -1 \end{bmatrix} \begin{bmatrix} x_1 \\ x_2 \\ x_3 \\ x_4 \end{bmatrix} = \begin{bmatrix} 15 \\ -13 \\ 4 \\ 3 \end{bmatrix}$	14	CO2
12	Find the largest eigen value by power method $A = \begin{bmatrix} 2 & 12 & 2 \\ 2 & 4 & 0 \\ 0 & 0 & 0 \end{bmatrix}$	14	CO2
<b>Module II</b>			
13	Obtain the cubic spline approximation of the given data and	14	CO3

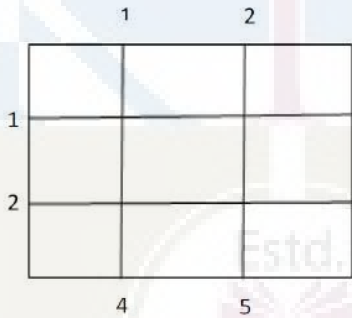
	determine $y(0.5)$ and $y'(0.2)$												
	<table style="margin-left: auto; margin-right: auto;"> <tr> <td style="padding: 0 10px;"><math>x</math></td> <td style="padding: 0 10px;">0</td> <td style="padding: 0 10px;">1</td> <td style="padding: 0 10px;">2</td> <td style="padding: 0 10px;">3</td> </tr> <tr> <td style="padding: 0 10px;"><math>y</math></td> <td style="padding: 0 10px;">-5</td> <td style="padding: 0 10px;">-4</td> <td style="padding: 0 10px;">3</td> <td style="padding: 0 10px;">6</td> </tr> </table>	$x$	0	1	2	3	$y$	-5	-4	3	6		
$x$	0	1	2	3									
$y$	-5	-4	3	6									
14	Evaluate $\int_0^6 \frac{1}{1+x^2} dx$ using (i) Simpson's 3/8 rule and Weddle's rule	14	CO3										
<b>Module III</b>													
15	Find $y(0.1)$ , $y(0.2)$ given $\frac{dy}{dx} = x - 2y = x - 2y$ , $y(0)=1$ taking $h=0.1$ using 4 <sup>th</sup> order Runge-Kutta method.	14	CO4										
16	Solve $y' = 1 + y^2$ , $y(0)=0$ Find $y(0.8)$ and $y(1)$ by Milne's predictor corrector method	14	CO4										
<b>Module IV</b>													
17	Solve the boundary value problem $xy'' + y = 0$ , $y(1)=1, y(2)=2$ take $h=1/4$	14	CO5										
18	Solve the equation $uxx + uyy = 0$ for the square mesh with boundary value as shown in figure	14	CO5										
													
<b>Module V</b>													
19	Solve $y'' + y + x = 0$ in the range $0 \leq x \leq 1$ by Galerkin's method. Given $y(0)=y(1)=0$	14	CO6										
20 (a)	Explain in detail the steps of finite element analysis	8	CO1, CO6										
20 (b)	Explain forms of shape functions in finite element analysis	6	CO1, CO6										

CET322	GEOTECHNICAL INVESTIGATION	CATEGORY	L	T	P	CREDIT	Year of Induction
		PEC	3	0	0	3	2019

**Preamble:**

Geotechnical Investigation is a course in the stream of Soil mechanics and foundation engineering. The course is aimed to impart to the students, a clear idea about how a geotechnical investigation program is to be planned and executed. It enables the students an in-depth knowledge of the various methods of geotechnical investigation and the field tests to be conducted in different situations. After the successful completion of the course, the students will be able to plan and execute the soil investigation at a site depending on the need and availability.

**Prerequisite: CE 208 Geotechnical Engineering -1**

**Course Outcomes**

CO 1	The students will be able to understand the procedure, applicability, and limitations of various methods of geotechnical investigation	Remembering, Understanding
CO 2	The students will be able to make engineering judgments and take appropriate decisions related to geotechnical investigations	Applying & Analysing
CO 3	The students will be able to understand the procedure and applications of penetration tests and geophysical tests for exploration of the soil profile	Remembering, Understanding
CO 4	The students will be able to choose the right soil sampling technique and analyse the dependability of samples collected	Applying & Analysing
CO5	The students will be able to understand the procedure and applications of field load tests and rock quality indices.	Applying & Analysing

**Mapping of the Course Outcomes with Programme Outcomes**

	PO1	PO2	PO3	PO4	PO5	PO6	PO7	PO8	PO9	PO10	PO11	PO12
CO 1	2		2	2								
CO 2	3	2	2	2								
CO 3	2				2							
CO 4	3	2	2	2								
CO 5	2				2							

## Assessment Pattern

CIVIL ENGINEERING

Bloom's Category	Continuous Assessment Tests		End Semester Examination (Marks)
	Test 1 (Marks)	Test 2 (Marks)	
Remember	15	15	30
Understand	10	10	20
Apply	25	25	50
Analyse			
Evaluate			
Create			

## Mark Distribution

Total Marks	CIE Marks	ESE Marks	ESE Duration
150	50	100	3 hours

## Continuous Internal Evaluation (CIE) Pattern

Attendance	:	10 Marks
Continuous Assessment Test (2 numbers)	:	25 Marks
Assignment/Quiz/Course project	:	15 Marks

## End Semester Evaluation (ESE) Pattern

There will be two parts; Part A and Part B. Part A contain 10 questions with 2 questions from each module, having 3 marks for each question. Students should answer all questions. Part B contains 2 questions from each module of which student should answer any one. Each question carries 14 marks and can have maximum 2 sub-divisions.

Note : 1.Each part should have at least one question from each module. 2.Each question can have a maximum of 4 subdivisions (a, b, c, d)

## Course Level Assessment Questions

(Questions may be framed based on the outline given under each course outcome)

**Course Outcome 1 (CO1):**The students will be able to understand the procedure, applicability, and limitations of various methods of geotechnical investigation.

1. Explain the various methods adopted for preliminary investigation.
2. What are the I.S. guidelines for deciding the number, size, spacing, and depth of boreholes?
3. What are the limitations of standard penetration test?

**Course Outcome 2 (CO2):**The students will be able to make engineering judgments and take appropriate decisions related to geotechnical investigations

1. Determine the bearing capacity, from a given SPT data.
2. Explain the procedures for geotechnical investigation of a profile which shows, rejection in SPT test.
3. What are the situations in which wash boring can be used as an exploration technique?

**Course Outcome 3 (CO3):**The students will be able to understand the procedure and applications of penetration tests and geophysical tests for exploration of the soil profile

1. Explain the procedure of determination of thickness of a strata using electrical resistivity method.
2. What are the effects of water table in geophysical methods?
3. What are the limitations of seismic refraction method?

**Course Outcome 4 (CO4):**The students will be able to choose the right soil sampling technique and analyse the dependability of samples collected.

1. What are the type of soil samples in a soil investigation procedure?
2. What are the factors affecting the quality of a soil sample?
3. Explain the methods of collection of soil samples.

**Course Outcome 5 (CO5):**The students will be able to understand the procedure and applications of field load tests and rock quality indices.

1. What are the limitations of a plate load test?
2. What are the situations in which pressure meter test becomes Ideal?
3. Explain the concept of subgrade reaction.
4. Explain the methods of representing the quality of rocks is a soil investigation report.

### Syllabus

Module	Content
I	Introduction and practical importance - Objectives of soil exploration– Planning of a sub-surface exploration program –Collection of existing information, reconnaissance, preliminary and detailed investigation - I.S. and other guidelines for deciding the number, size, spacing, and depth of boreholes Methods of exploration - Open pits – Auger boring- -Wash boring, percussion drilling, rotary drilling



II	Sounding methods Standard Penetration Test – Procedure – corrections to be applied to observed N values – Numerical examples – Factors influencing the SPT results and precautions to obtain reliable results – Merits/drawbacks of the test – Correlations of N value with various engineering and index properties of soils Static Cone Penetration Test – Procedure – Merits/drawbacks – Correlation of static CPT results with soil properties – Dynamic Cone Penetration Test – Brief Procedure – Merits/drawbacks – Critical comparison of SPT, static CPT, and dynamic CPT
III	Geophysical methods – Seismic refraction method – Procedure, uses, limitations – Solution of numerical problems to estimate the velocity of seismic waves and the thickness of the upper layer of a two-layered soil system - Electrical resistivity method – Electrical profiling and electrical sounding – Procedure, uses, limitations Stabilization of boreholes, Groundwater level estimation
IV	Soil sampling – Undisturbed, disturbed, and representative samples – Chunk and tube samples – Factors affecting sample disturbance and methods to minimize them – Area ratio - Inside clearance – Outside clearance - Recovery ratio – Ball check valve – Numerical Problems – Handling and transportation of samples – Extrusion of samples Types of samplers – Thin-walled sampler – Piston sampler – Split spoon sampler – Methods for collection of sand samples from beneath the water table - Core retainers
V	Pressure meter test - Procedure – Uses – limitations, Flat Dilatometer Test (Brief only) Plate load test – Procedure, uses, and limitations – modulus of subgrade reaction- Solution of numerical problems using plate load test data Rock core sampling, Rock Quality Designation, Core Recovery Ratio – Bore log – Soil profile – Sub-soil investigation report

**Textbooks:**

1. Gopal Ranjan and Rao A.S.R., “Basic and Applied Soil Mechanics”, New Age International (P) Limited, New Delhi, 2002.
2. Venkata Ramaiah, “Geotechnical Engineering”, Universities Press (India) Limited, Hyderabad, 2000.

**References:**

1. Arora K.R., “Geotechnical Engineering”, Standard Publishers Distributors, New Delhi, 2006.
2. Joseph E. Bowles, „Foundation Analysis and Design“, Mc. Graw Hill Inc., New York, 1988.
3. Purushothamaraj P., Soil Mechanics and Foundation Engineering, Dorling Kindersley(India) Pvt. Ltd., 2013
4. Terzaghi K. and R. B. Peck, Soil Mechanics in Engineering Practice, John Wiley, 1967.

**Course content and Lecture schedule**

<b>Module</b>	<b>Contents</b>	<b>Outcomes Addressed</b>	<b>Hours</b>
<b>I</b>	<b>Module 1</b>		<b>7</b>
1.1	Introduction and practical importance - Objectives of soil exploration –	CO1	1
1.2	Planning of a sub-surface exploration program – Collection of existing information,	CO1	1
1.3	reconnaissance, preliminary and detailed investigation	CO1	1
1.4	I.S. and other guidelines for deciding the number, size, spacing, and depth of boreholes	CO1	1
1.5	Methods of exploration - Open pits – Auger boring-	CO1	1
1.6	Wash boring, percussion drilling, rotary drilling	CO1	2
	<b>Module 2</b>		<b>7</b>
<b>II</b>			
2.1	Sounding methods Standard Penetration Test – Procedure	CO3	1
2.2	corrections to be applied to observed N values – Numerical examples	CO2	1
2.3	Factors influencing the SPT results and precautions to obtain reliable results – Merits/drawbacks of the test	CO2	1
2.4	Correlations of N value with various engineering and index properties of soils	CO2	1
2.5	Static Cone Penetration Test – Procedure Merits/drawbacks	CO3	1
2.6	Correlation of static CPT results with soil properties	CO2	1
2.7	-Dynamic Cone Penetration Test – Brief Procedure – Merits/drawbacks – Critical comparison of SPT, static CPT, and dynamic CPT	CO3	1
	<b>Module 3</b>		<b>7</b>
<b>III</b>			
3.1	Geophysical methods – Seismic refraction method – Procedure	CO3	1
3.2	uses, limitations	CO3	1
3.3	Solution of numerical problems to estimate the velocity of seismic waves and the thickness of the upper layer of a two-layered soil system	CO3	2
3.4	Electrical resistivity method – Electrical profiling and electrical sounding – Procedure	CO3	1
3.5	uses, limitations	CO3	1
3.6	Stabilization of boreholes, Groundwater level estimation	CO4	1

<b>Module 4</b>			<b>7</b>
IV			
4.1	Soil sampling – Undisturbed, disturbed, and representative samples –	CO4	1
4.2	Chunk and tube samples – Factors affecting sample disturbance and methods to minimize them –	CO4	1
4.3	Area ratio - Inside clearance – Outside clearance - Recovery ratio –Ball check valve –	CO4	1
4.4	Numerical Problems	CO4	1
4.5	Handling and transportation of samples – Extrusion of samples	CO4	1
4.6	Types of samplers – Thin-walled sampler – Piston sampler – Split spoon sampler –	CO4	1
4.7	Methods for collection of sand samples from beneath the water table - Core retainers	CO4	1
<b>Module 5</b>			<b>7</b>
V			
5.1	Pressure meter test - Procedure – Uses – limitations,	CO5	1
5.2	Flat Dilatometer Test (Brief only)	CO5	1
5.3	Plate load test – Procedure, uses, and limitations –	CO5	1
5.4	modulus of subgrade reaction- Solution of numerical problems using plate load test data	CO5	2
5.5	Rock core sampling, Rock Quality Designation, Core Recovery Ratio	CO5	1
5.6	Bore log – Soil profile – Sub-soil investigation report	CO1	1



QP CODE:

Reg No.: \_\_\_\_\_

Name: \_\_\_\_\_

**APJ ABDUL KALAM TECHNOLOGICAL UNIVERSITY**  
SIXTH SEMESTER B. TECH DEGREE EXAMINATION, MONTH & YEAR

**Course Code: CET 322**

**Course Name: GEOTECHNICAL INVESTIGATION**

**Max. Marks: 100**  
**hours**

**Duration: 3**

**Part A**

**(Answer all questions; each question carries 3 marks)**

1. What are the objectives of soil exploration?
2. Differentiate preliminary investigation and detailed investigation.
3. Explain dilatancy correction to be applied to the N value.
4. List out the factors influencing SPT value.
5. Explain stabilization of borehole using Bentonite slurry.
6. Write the principle behind the seismic refraction method.
7. What are the precautions to be adopted during the transportation of sample?
8. Define i) Area ratio, ii) Inside clearance iii) Outside clearance
9. Differentiate between bore log and soil profile.
10. What is rock quality designation?

**Part B**

**(Answer one full question from each module, each question carries 14 marks)**

**Module 1**

11. **a.** Explain wash boring with the help of a sketch.  
**b.** Explain the major steps involved in reconnaissance for a geotechnical investigation of a multi storied building.

**OR**

12. **a.** Differentiate preliminary investigation and detailed investigation.  
**b.** Explain percussion drilling with the help of a sketch.

**Module 2**

13. **a.** The observed SPT value (N) in a deposit of fully submerged fine silty sand was 45 at a depth of 6.5m. The average saturated unit weight of soil is 19.5 kN/m<sup>3</sup> Find the corrected SPT number.  
**b.** Explain the factors influencing SPT value.

**OR**

14. **a.** The field N value in a deposit of fully submerged fine sand was 47 at a depth of 7m. The average saturated unit weight of the soil is  $19\text{kN/m}^3$ . Calculate the corrected N value.
- b.** Explain the procedure for conducting SPT test with neat figure.

### Module 3

15. **a.** Explain the seismic refraction method  
**b.** Explain the procedure to employ electrical sounding method.

**OR**

16. **a.** Explain the electrical profiling method.  
**b.** Explain stabilization of borehole using Bentonite slurry.

### Module 4

17. **a.** Explain any two types of samplers used for undisturbed soil sample.  
**b.** If the external diameter of a sampling tube is 75 mm and area ratio is 20%, determine the thickness of sampling tube.

**OR**

18. **a.** Explain the factors affecting sample disturbance. What are the precautions to be taken in handling and transporting soil samples?  
**b.** Compute the area ratio of a thin walled tube sampler of external diameter 6.0 cm and wall thickness 2.25mm and comment on the type of soil sample obtained using this sampler.

### Module 5

19. **a.** What is a bore log and draw an example of bore log?  
**b.** What are the salient features of a sub soil investigation report? With a neat sketch, explain the term 'soil profile'.

**OR**

20. **a.** Explain Pressure meter test and comment on the Uses and limitations  
**b.** Two plate load tests with square plates were performed on a soil deposit. For a 30 mm settlement, the following loads were obtained. Determine the width of a square footing which would carry a net load of 1,500 kN for a limiting settlement of 30 mm.

Width of square plate in mm	Load in kN
300	38.2
600	118.5

CET332	TRAFFIC ENGINEERING AND MANAGEMENT	CATEGORY	L	T	P	CREDIT	Year of Introduction
		PEC	3	0	0	3	2019

**Preamble :** The course aims to impart in-depth knowledge pertinent to traffic flow theory, traffic management measures, capacity analysis, design of road intersections and road safety.

**Prerequisite:** CET 206 Transportation Engineering

**Course Outcomes:**

After the completion of the course the students will be able to

CO 1	Identify the relationship among various traffic stream variables. (K2, K3)
CO 2	Apply traffic management measures and regulations so as to solve issues related to traffic flow in road network. (K2, K3)
CO 3	Explain the concept of capacity and LOS and its estimation for various traffic facilities (K2,K3)
CO 4	Identify the need for intersection control and design of various types.(K2,K3)
CO 5	Analyse causes of road accidents and suggest preventive measures (K2, K3)

**Mapping of course outcomes with program outcomes**

	PO1	PO2	PO3	PO4	PO5	PO6	PO7	PO8	PO9	PO10	PO11	PO12
CO 1	3	3	2									
CO 2	3					3						
CO 3	3	2		2		2						2
CO 4	3	2	3	2		2	3					2
CO 5	3	2	2	3		3						2

**Assessment Pattern**

Bloom's Category	Continuous Assessment		End Semester Examination (marks)
	Test 1 Marks	Test 2 Marks	
Remember	5	5	20
Understand	10	10	40
Apply	5	5	20
Analyse	5	5	20
Evaluate			
Create			

**Mark Distribution**

Total Marks	CIE (Marks)	ESE (Marks)	ESE Duration
150	50	100	3 hours

**Continuous Internal Evaluation Pattern:**

Attendance	: 10 marks
Continuous Assessment Test (2 numbers)	: 25 marks
Assignment/Quiz/Course Project	: 15 marks

**End Semester Examination Pattern:**

The question consists of two parts- Part A and Part B. Part A consists of 10 questions with 3 marks for each (two questions from each module). Part B consists of two questions from each module, out of which one has to be answered. Each question carries 14 marks and can have maximum 2 subdivisions.

**Sample Course Level Assessment Questions: 2014**

**Course Outcome 1 (CO1):** Illustrate through diagrams the basic relationship between the fundamental variables of traffic flow.

**Course Outcome 2 (CO2):** Suggest traffic management measures so as to avoid locking of vehicle flow due to turning traffic.

**Course Outcome 3 (CO3):** Define adjusted capacity. What are the measures of effectiveness used for urban roads and two lane highways?

**Course Outcome 4 (CO4):** Explain the hierarchy of intersection control. What do you understand by optimum cycle length?

**Course Outcome 5 (CO5):** With neat sketches differentiate between collision and condition diagram

**Syllabus- Traffic Engineering and Management**

<p><b>Module 1</b></p>	<p><b>Traffic Flow Characteristics: <i>Fundamental Parameters</i></b>- speed, density, volume, travel time, headway, spacing, time-space diagram, time mean speed, space mean speed and their relation. Fundamental diagrams of traffic flow.  <b>Traffic stream models:</b> Single Regime models - Greenshields model, Greenberg logarithmic model                  Multi-regime models – Two and three regime linear models.</p>
<p><b>Module 2</b></p>	<p><b>Regulation of Traffic</b> – Need and scope of traffic regulations- Motor Vehicle Act – Regulation of speed- Regulation of vehicles – Regulations concerning driver- General rules concerning traffic- parking regulations- Enforcement of regulations.  <b>Traffic Management</b> – scope of traffic management measures – restrictions to turning movements – one way streets – tidal flow operations-Closing side streets – Exclusive bus lanes.</p>
<p><b>Module3</b></p>	<p><b>Capacity and Level of service (LOS):</b> Concept- Base capacity, Adjusted capacity, LOS definition, Factors Affecting Capacity and LOS, Homogeneous and heterogeneous traffic conditions-vehicle types - Concept of PCU.                  Capacity and LOS analysis –Single lane, Intermediate lane and two lane interurban roads- Base capacity and adjustment factors- Indo HCM (2017) Guidelines                  Capacity and LOS analysis of Urban roads - Base conditions- Adjustment factors- Indo HCM (2017) Guidelines</p>
<p><b>Module 4</b></p>	<p><b>Intersections:</b> At-grade intersections- basic forms- conflict points -visibility triangle- design principles- Channelization.                  Roundabouts- Geometric layout, types- design elements.                  Traffic Signals –Warrants- pre-timed and traffic actuated.                  Design of signal timing at isolated intersections- Phase design-optimum cycle time (Webster’s approach), green splitting- pedestrian phase -phase diagrams, timing diagram.                  Grade separated intersection: Grade separated intersections without interchange and with interchange- Three leg interchange, Four leg interchange and multileg interchange.  <b>Traffic Control Measures</b> - Traffic Signs, Road Markings, and Traffic control aids.</p>
<p><b>Module 5</b></p>	<p><b>Traffic Safety :</b> Road Safety Situation in India, Causes of road accidents –</p>



	influence of road, vehicle, driver and environmental factors - Pedestrian Safety, Collection and statistical analysis of accident data, Collision and condition diagram, <b>Road Safety Audit-</b> concept and need- organizations involved- stages of road safety audit (brief description only)
--	------------------------------------------------------------------------------------------------------------------------------------------------------------------------------------------------------------------------------------------------------------------------------------------------------

### Text Books:

1. Kadiyali L.R. Traffic Engineering and Transport planning, Khanna Publishers, 2011
2. Khanna S.K and Justo C.E.G; Highway Engineering, Nem Chand Publishers, 10<sup>th</sup> Ed, 2018.
3. CAO' Flaherty, Transport planning and Traffic Engineering, Elsevier, 2006.

### References

1. Roger P. Roess, William R. McShane & Elena S. Prassas, Traffic Engineering, Fourth Edition, Prentice-Hall, 2010.
2. Pignataro L. J., Traffic Engineering – Theory and Practice, Prentice Hall, 1973.
3. C. J. Khisty and B. K. Lall, Transportation Engineering: An Introduction, Prentice-Hall India, 2002.
4. P. Chakroborty and A. Das, Principles of Transportation Engineering, PrenticeHall of India Pvt. Ltd., 2003.
5. A. D. May, Traffic Flow Fundamentals, Prentice-Hall, 1990.
6. C.S. Papacostas, Transportation Engineering and Planning, Prentice-Hall India, 2002.
7. Highway Capacity Manual (HCM), Transportation Research Board, USA, 2010.
8. Indian Highway Capacity Manual (Indo-HCM), CSIR, New Delhi, 2017
9. Relevant IRC codes

### **Course Content and lecture Schedule:**

No.	Topic	Course Outcome	No. of Hrs
1	<b>Module 1</b>		Total: 7
1.1	<b>Fundamental parameters-</b> speed, density, volume, travel time, headway, spacing, time-space diagram, time mean speed, space mean speed and their relation. Fundamental diagrams of traffic flow.	CO1	2
1.2	<b>Single Regime models</b> - Greenshields model, Greenberg logarithmic model	CO1	3
1.3	<b>Multi-Regime models</b> – Two and three regime linear models.	CO1	2
2	<b>Module 2</b>		Total: 7

2.1	Need and scope of traffic regulations- Motor Vehicle Act – Regulation of speed- Regulation of vehicles – Regulations concerning driver- General rules concerning traffic- parking regulations- Enforcement of regulations.	CO2	4
2.2	Scope of traffic management measures – restrictions to turning movements – one way streets – tidal flow operations-Closing side streets –Exclusive bus lanes.	CO2	3
3	<b>Module 3</b>		Total: 7
3.1	<b>Capacity and Level of service (LOS):</b> Concept- Base capacity, Adjusted capacity, LOS definition, Factors Affecting Capacity and LOS, Homogeneous and heterogeneous traffic conditions- vehicle types - Concept of PCU.	CO3	2
3.2	Capacity and LOS analysis –Single lane, Intermediate lane and two lane interurban roads- Base capacity and adjustment factors- Indo HCM (2017) Approach	CO3	3
3.3	Capacity and LOS analysis of Urban roads - Base conditions- Adjustment factors- Indo HCM (2017) approach	CO3	2
4	<b>Module 4</b>		Total: 9
4.1	<b>Intersections:</b> At-grade intersections- basic forms- conflict points -visibility triangle- design principles- Channelization.	CO4	2
4.2	<b>Roundabouts-</b> Geometric layout, types- design elements.	CO4	2
4.3	<b>Traffic Signals</b> - Warrants- pre-timed and traffic actuated. Design of signal timing at isolated intersections- Phase design- optimum cycle time (Webster’s approach), green splitting- pedestrian phase -phase diagrams, timing diagram.	CO4	3
4.4	<b>Grade separated intersection:</b> Grade separated intersections without interchange, and with interchange- Three leg interchange, Four leg interchange and multileg interchange. <b>Traffic Control Measures</b> - Traffic Signs, Road Markings, Traffic control aids.	CO4	2
5	<b>Module 5</b>		Total: 5
5.1	<b>Traffic Safety :</b> Road Safety Situation in India, Causes of road accidents – influence of road, vehicle, driver and environmental factors - Pedestrian Safety, Collection and statistical analysis analysis of accident data, Collision and condition diagram,	CO5	3
5.2	<b>Road safety audit-</b> concept and need- organizations involved- stages of road safety audit (brief description only)	CO5	2

**APJ ABDUL KALAM TECHNOLOGICAL UNIVERSITY  
SIXTH SEMESTER B. TECH DEGREE EXAMINATION, MONTH & YEAR**

Course Code: CET332

Course Name: **TRAFFIC ENGINEERING AND MANAGEMENT**

**Model Question Paper**

Max. Marks:100

Duration: 3 hrs

**PART A**

**(Answer all Questions: Each question carries 3 marks)**

- 1 Differentiate time mean speed and space mean speed.
- 2 Explain multi regime models citing examples.
- 3 Suggest traffic management measures so as to avoid locking of vehicle flow due to turning traffic.
- 4 Mention priority rules at intersections.
- 5 Explain base capacity and adjusted capacity.
- 6 Discuss the importance of passenger car units under heterogeneous traffic conditions.
- 7 How channelizing islands control speed and separate conflicts at intersections? Explain with sketches.
- 8 Which locations justify grade- separated intersections?
- 9 What is the basic difference between collision diagram and condition diagram?
- 10 What is the probability of involvement of exactly 5 drivers out of the 500 drivers who are employed in a bus operating company in an accident during a year. It has been found that on an average 1 in 100 drivers are involved in an accident every year.

(3 x 10=30 marks)

**PART B**

**(Answer one full question from each module)**

- 11 a. The data shown below were obtained from a highway stretch. Fit these data to Greenshields model and determine i) free speed ii) jam density iii) capacity and iv) speed at maximum flow 7

Speed (km/h)	Density (veh/km)
14.2	85
24.1	70
30.3	55
40.1	41
50.6	20

55	15
----	----

- b. Explain single regime speed- density models 7

**OR**

- 12 a. Observers stationed at two sections XX and YY, 150m apart on a highway, record the arrival times of four vehicles as shown in the accompanying table. If the total time of observation at XX was 15 s, determine a) the time mean speed, b) the space mean speed and c) the flow at section XX. 7

Vehicle	Time of Arrival ( Seconds)	
	Section XX	Section YY
A	$T_0$	$T_0 + 7.58$
B	$T_0 + 3$	$T_0 + 9.18$
C	$T_0 + 6$	$T_0 + 12.36$
D	$T_0 + 12$	$T_0 + 21.74$

- b. Using basic stream flow diagram, explain speed- density, speed- flow and flow- density relationships 7
- 13 a. Mention general principles governing speed limit in urban area and rural area. 7
- b. Suggest traffic management measures that can take care of the imbalance in directional distribution of traffic during peak hours. 7

**OR**

- 14 Explain the aspects covered under regulation of vehicles and regulation concerning driver in motor vehicles act. 14
- 15 a. Explain the adjustment factors mentioned in Indo HCM (2017) that are to be considered in the capacity estimation of urban roads. 7
- b. Differentiate base capacity and adjusted capacity of single lane interurban roads. 7

**OR**

- 16 a. What is level of service? What are the factors affecting capacity and level of service? 7
- b. Explain the procedure mentioned in Indo HCM (2017) for the determination of base capacity and level of service of two lane two way interurban roads. 7
- 17 a. Draw a neat sketch of a full cloverleaf and show the movement of traffic. 7
- b. Show conflict points at the following intersections 7
- i) cross roads, both two way, ii) T-intersection, both two way roads iii) Y-intersection, one one-way iv) Cross roads, one way roads

**OR**

- 18 a. Explain briefly the various design factors that are to be considered in rotary intersection design. 7
- b. Design a four phase signal timing plan for the data given below. The intersection is four legged. All approaches have 3 lanes and each lane is 3.5 m width. Saturation flow is 1800pcu/hr/lane. The equivalent hourly flows at the intersection are as shown below: Using the Webster model, determine the optimal cycle length for the intersection. Assume lost times equal to 3.5 s/phase, amber interval equal to 3 s, and all red period is not provided. Also draw the phase and timing diagram. 7

East bound			West bound			North bound			South bound		
L	T	R	L	T	R	L	T	R	L	T	R
280	850	80	320	700	120	50	280	40	35	360	10

- 19 a. What are the different methods for maintaining accident records? Briefly explain with neat sketches. 7
- b. Explain various measures that may be taken to prevent accidents. 7
- OR**
- 20 a. Briefly explain various stages of road safety audit. 7
- b. Explain any three statistical methods for analysis of accident data. 7



CET342	MECHANICS OF FLUID FLOW	Category	L	T	P	Credit	Year of Introduction
		PEC	3	0	0	3	2019

**Preamble:** The general objective of this course is to expose the students to the fundamental concepts of different types of fluid flow.

**Pre-requisite:** CET203 Fluid Mechanics and Hydraulics

**Course outcome**

CO1	Describe and apply the principles of potential flow and viscous flow
CO2	Perform the computations of turbulent flows through pipes and pipe bends by recollecting the relevant hydraulic principles
CO3	Describe and apply the principles of the pressure and specific energy in open channel flow for practical applications
CO4	Describe and apply the principles of unsteady flow for practical applications in pipes and channels
CO5	Prepare physical models for performing experiments recalling the principles of fluid flow

**CO-PO Mapping**

MECHANICS OF FLUID FLOW		PO1	PO2	PO3	PO4	PO5	PO6	PO7	PO8	PO9	PO10	PO11	PO12
	CO1	3	3					1					
	CO2	3	3					1					
	CO3	3	3					1					
	CO4	3	3					1					
	CO5	3	3										

**Assessment pattern**

Bloom's Category	Continuous Assessment Tests		End Semester Examination (Marks)
	Test 1 (Marks)	Test 2 (Marks)	
Remember	5	5	15
Understand	10	10	15
Apply	20	20	40
Analyze	15	15	30
Evaluate			

Create			
--------	--	--	--

**Continuous Internal Evaluation Pattern:**

Attendance	:	10 marks
Continuous Assessment Test(2 numbers)	:	25 marks
Assignment/Quiz/Course project	:	15 marks
<b>Total</b>	:	<b>50 marks</b>

**End semester examination pattern** – There will be two parts; Part A and Part B. Part A contain 10 questions with 2 questions from each module, having 3 marks for each question. Students should answer all questions. Part B contains 2 questions from each module of which student should answer any one. Each question can have maximum 2 sub-divisions and carry 14 marks.

**Course Code: CET 342**  
**MECHANICS OF FLUID FLOW**  
**(Course plan)**

Module	Topic	Course outcome addressed	No of Hours
<b>Module I (8 Hours)</b>			
1.1	Fluid flow: Types of fluid flow (Review)	CO1	1
1.2	Potential flow-velocity potential and stream function	CO1	1
1.3	Problems on velocity potential and stream function	CO1	1
1.4	Streamlines and equipotential lines, flow net-uses and limitations	CO1	1
1.5	Flow through pipes: Viscous flow - Shear stress, pressure gradient relationship Laminar flow-Basic concepts, Reynold's experiment	CO1	1
1.6	Laminar flow between parallel plates	CO1	1
1.7	Hagen-Poiseuille equation	CO1	1
1.8	Problems	CO1	1

<b>Module II (7 Hours)</b>			
2.1	Turbulent flow- fundamentals	CO2	1
2.2	Velocity profile- computations	CO2	1
2.3	Pipe roughness -friction factor- Moody's diagram; Hazen williems formula	CO2	1
2.4	Head loss due to friction in pipes-Nikuradse experiment with artificially roughened pipe	CO2	1
2.5	Reduction of carrying capacity of pipes with age	CO2	1
2.6	Flow through pipe bends- application of linear momentum principle	CO2	1
2.7	Problems on Flow through pipe bends	CO2	1
<b>Module III (7 Hours)</b>			
3.1	Open channel flow- uniform flow and critical flow computations- section factor	CO3	1
3.2	Hydraulic exponents for uniform flow and critical flow	CO3	1
3.3	Computation of discharge through compound channels	CO3	1
3.4	Pressure distribution in curvilinear flows- spillway crest and spillway buckets	CO3	1
3.5	Specific energy (review)- Application of Specific energy for channel transitions- hump and reduction in channel width	CO3	1
3.6	Application of Specific energy for channel transitions- reduction in channel width	CO3	1
3.7	Problems on Application of Specific energy for channel transitions	CO3	1
<b>Module IV (7 Hours)</b>			
4.1	Rapidly varied steady flow-hydraulic jumps –tail water conditions -types	CO4	1
4.2	Uses of hydraulic jumps for energy dissipation below spillways- jump height curve; tail water curve	CO4	1
4.3	Unsteady flow through open channels- Surges in open channels- Positive surges and negative surges (concept only)	CO4	1
4.4	Positive surges – derivation of equations-continuity and momentum	CO4	1



4.5	Problems on Positive surges	CO4	1
4.6	Unsteady flow through pipes –water hammer analysis	CO4	1
4.7	Problems on water hammer analysis	CO4	1
<b>Module V (6 Hours)</b>			
5.1	Experimental hydraulics- Dimensional analysis Dimensional analysis-Dimensions and dimensional homogeneity	CO5	1
5.2	Rayleigh method-Problems	CO5	1
5.3	Buckingham pi theorem- Problems	CO5	1
5.4	Model Analysis-Dimensionless numbers, Similitude	CO5	1
5.5	Model laws and scale ratios- Problems	CO5	1
5.6	Scale effect, distorted and undistorted models	CO5	1

**Course Code: CET342**  
**MECHANICS OF FLUID FLOW**  
**Syllabus**

**Module I**

Fluid flow: Types of fluid flow (Review) Potential flow-velocity potential, stream function, streamlines and equipotential lines, flow net-uses and limitations

Viscous flow –Reynold’s experiment; Shear stress- pressure gradient relationship - Laminar flow through pipes (Hagen-Poiseulle Equation), laminar flow between stationary parallel plates

**Module II**

Turbulent flow- Computation, velocity distribution, Head loss due to friction in pipes-Nikuradse experiment with artificially roughened pipe, Friction coefficient for laminar and turbulent flows, Moody’s diagram, reduction of carrying capacity of pipes with age. Hazen William’s formula. Flow through pipe bends - application of linear momentum principle

**Module III**

Open channel flow-Hydraulic exponents and section factor for uniform and critical flow, Pressure distribution in curvilinear flows- spillway crest and spillway bucket. Computation of discharge through compound channels. Application of Specific energy for channel transitions-hump and reduction in channel width

**Module IV**

Rapidly varied steady flow-hydraulic jumps –types based on tail water conditions; Uses of hydraulic jumps for energy dissipation below spillways- jump height curve; tail water curve  
Unsteady flow through open channels – Surges- positive surges (problems) and concept of negative surges; Transients in pipes-water hammer

**Module V**

Experimental hydraulics- Physical modeling-Dimensional analysis- Reyleigh's method  
Buckingham's pi- theorem, Similitude, Model laws for viscous and open channel flows-  
Reynold's and Froude's model law; Scale effect, distorted and undistorted models

**Text Books:**

1. Modi P. N. and S. M. Seth, Hydraulics & Fluid Mechanics, S.B.H Publishers, New Delhi, 2002.
2. Subramanya K., Theory and Applications of Fluid Mechanics, Tata McGraw-Hill, 1993.
3. Subramanya K., Flow in Open channels, Tata McGraw-Hill, 2009.

**References**

1. Streeter.V.L. Fluid Mechanics, Mc Graw Hill Publishers.
2. Bruce R Munson, Donald F Young . Fundamentals of Fluid Mechanics, John Wiley & sons, 2011.
3. Jain A. K., Fluid Mechanics, Khanna Publishers, Delhi, 1996.
4. Arora.K.R. Fluid Mechanics, Hydraulics and Hydraulic Machines, Standard Publishers, 2005.
5. Narasimhan S., A First Course in Fluid Mechanics, University Press (India) Pvt. Ltd., 2006.
6. Frank.M.White, Fluid Mechanics, Mc Graw Hill, 2013.
7. Mohanty.A.K. Fluid Mechanics, Prentice Hall, New Delhi, 2011
8. Narayana Pillai,N. Principles of Fluid Mechanics and Fluid Machines, University Press, 2011.
9. Kumar.D.N. Fluid Mechanics and Fluid power Engineering, S.K.Kataria & sons, 2013.

**Course Code: CET 342**  
**MECHANICS OF FLUID FLOW**  
**(Course Level Assessment Questions)**

<b>CO1</b>	<b>Describe and apply the principles of potential flow and viscous flow</b>
1	Describe Reynold's experiment
2	Show that stream lines and equi potential lines intersect orthogonally
3	Crude oil of dynamic viscosity 1.5 Poise and relative density 0.9 flows through a 20 mm vertical pipe. The pressure gauges fitted at an upper point A measures 58.86 N/cm <sup>2</sup> while that fitted at another point B, 20 m below A reads 19.62 N/cm <sup>2</sup> . Is the flow laminar ? Find the direction of flow and rate of flow.
4	Obtain the expression for local velocity of steady, uniform laminar flow through the space between two stationary parallel plates. Also show that the local velocity becomes average velocity at a point 0.211B from one of the plates, where B is the spacing between the plates
5	The velocity components in a two dimensional incompressible flow are $u = \frac{y^3}{3} + 2x - x^2y$ and $v = xy^2 - 2y - \frac{x^3}{3}$ . (i) Is the flow irrotational? (ii) Evaluate the potential function and stream function

<b>CO2</b>	<b>Perform the computations of turbulent flows through pipes and pipe bends</b>
1	Explain the use and characteristics of Moody's diagram
2	Describe the characteristics of velocity distribution in turbulent regime
3	Explain the role of surface aging in carrying capacity of commercial pipes
4	360 l/sec of water is flowing in a pipe. The pipe is bent by 120°. The pipe bend measures 360 mm x 240 mm and volume of the bend is 0.14 m <sup>3</sup> . The pressure at entrance is 73 kN/m <sup>2</sup> and the exit is 2.4 m above the entrance section. Find the magnitude of resultant force exerted on the bend.
5	A pipeline 30 cm diameter carries 300 l/s of petrol (density=600 kg/m <sup>3</sup> ; dynamic viscosity=2.9 x 10 <sup>-4</sup> Pas). Calculate (i) the friction factor (ii) shear stress at the boundary (iii) shear stress and velocity at 5 cm from the pipe axis (iv) maximum velocity and thickness of laminar sublayer Assume the pipe to be hydrodynamically rough

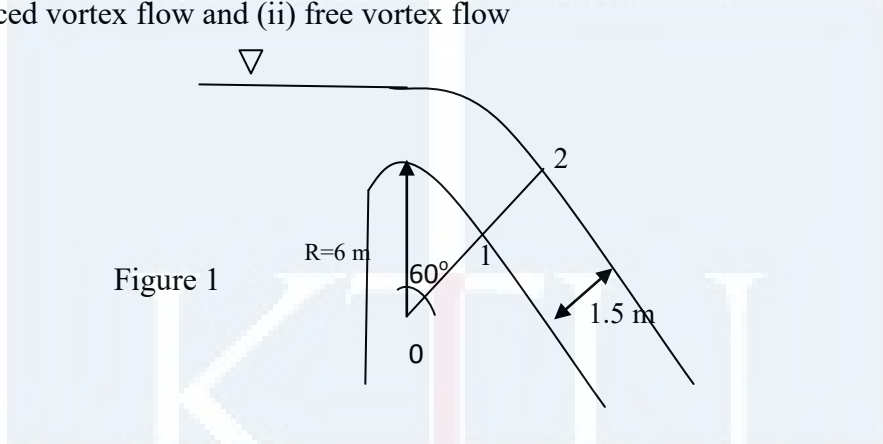
<b>CO3</b>	<b>Describe and apply the principles of the pressure and specific energy in open channel flow for practical applications</b>
1	Explain hydraulic exponents in open channel computation
2	Derive the relations for Pressure distribution in curvilinear flows
3	A discharge of 15 cumecs flows through a rectangular channel 3 m wide. The depth of flow is 2 m. What is the minimum width beyond which the flow depth at upstream gets disturbed ? A smooth hump of 0.1 m is built in the channel and at this section the width is 2.8 m. Analyze the water depth at contracted section and the upstream section.
4	<p>For the flow over a spillway with circular arc shown in Figure 1, obtain the value of pressure at point 1 for discharge <math>q=5 \text{ m}^3/\text{s}/\text{m}</math> for a constant flow depth of 1.5 m assuming (i) forced vortex flow and (ii) free vortex flow</p>  <p>Figure 1</p>

<b>CO4</b>	<b>Describe and apply the principles of unsteady flow for practical applications in pipes and channels</b>
1	Explain negative surges. Give examples
2	What is water hammer in pipes ?
3	A steel pipeline is 30 cm in diameter and has a wall thickness of 3 mm. The pipe is 1000 m long and conveys a flow of 100 l/s (Relative density =0.82).The static head at the outlet is 160 m of oil. If the working stress of steel is 0.1 kN/mm <sup>2</sup> , calculate the minimum time of closure of a downstream valve. For oil, $K=10^9 \text{ Pa}$ and for steel $E=2.14 \times 10^{11} \text{ Pa}$
4	A horizontal rectangular channel of 3 m width and 2 m water depth conveys water at 18 m <sup>3</sup> /sec. If the flow rate is suddenly reduced to 2/3 of its original value, compute the height and velocity of the surge developed in the channel

<b>CO5</b>	<b>Prepare physical models for performing experiments recalling the principles of fluid flow</b>
1	Describe Reyligh's method of dimensional analysis
2	Describe scale effect in physical model studies
3	Explain similitude in hydraulic model studies
4	A 1:20 spillway model has a discharge of 2.25 m <sup>3</sup> /s. what is the corresponding prototype discharge ? If a flood phenomenon takes 10 h to occur in the prototype, how long will it in the model ?
5	<p>The discharge <math>Q</math> over a small rectangular weir is known to depend upon head <math>H</math> over the weir, the height of the weir <math>P</math>, acceleration due to gravity <math>g</math>, width of the weir <math>L</math> and fluid properties <math>\rho</math>, dynamic viscosity <math>\mu</math> an surface tension <math>\sigma</math>. Express the relationship between the variables in dimensionless form</p> $\frac{Q}{gH^{5/2}} = f\left[\frac{P}{H}, \frac{L}{H}, \frac{\mu}{H^{3/2}g^{1/2}\rho}, \frac{\sigma}{\rho gH^2}\right] \text{ using Buckingham } \pi \text{- theorem}$

Pages: 3

Model Question Paper

Reg No.:.....

QP CODE:.....

Name:.....

APJ ABDUL KALAM TECHNOLOGICAL UNIVERSITY  
SIXTH SEMESTER B.TECH DEGREE EXAMINATION, MONTH & YEAR

Course Code: CET342

Course Name: MECHANICS OF FLUID FLOW

Max. Marks: 100

Duration: 3 hours

Part A

(Answer all questions; each question carries 3 marks)

1. Describe Reynold's experiment.
2. Explain the uses of flownet.
3. Describe the features of Moody's diagram.
4. Explain the concept of application of linear momentum principle in pipe bends.
5. Define section factor for uniform flow and critical flow computations and state their uses.
6. Describe the application of specific energy concept in channel transitions.
7. Enlist the classification of hydraulic jumps based on tail water conditions.
8. Differentiate positive surges and negative surges.
9. Explain similitude in hydraulic model studies.
10. Differentiate distorted and undistorted models.

Part B

(Answer one full question from each module, each question carries 14 marks)

Module I

11. (a) Derive Hagen-Poiseuille equation (10Marks)  
(b) Obtain the relation between mean velocity and maximum velocity of laminar flow between parallel plates (4 Marks)

Or

12. (a). The velocity potential for a two dimensional flow is  $\phi = x(2y - 1)$  at P(4,5) determine  
(i) the velocity and (b) stream function (10Marks)

12. (b) Show that the streamlines and equipotential lines are orthogonal to each other  
(4 Marks)

### Module II

13. The diameter of a pipe bend is 30 cm at inlet and 15 cm at outlet and the flow is turned through  $120^\circ$  in a vertical plane. The axis at inlet is horizontal and the centre of the outlet section is 1.5 m below the centre of the inlet section. Total volume of water in the bend is 0.9 m<sup>3</sup>. Neglecting friction, calculate the magnitude and direction of force exerted on the bend by water flowing through it at 250 l/sec and when the inlet pressure is 0.15N/mm<sup>2</sup>

(14 Marks)

Or

14. A 300 mm diameter water supply pipe had a friction factor of 0.02 when freshly laid. After 10 years of service, the friction factor was found to be 0.025. what friction factor can be expected after another 15 years ? The pipe is assumed to be in rough turbulent flow regime (14 Marks)

### Module III

15. Derive the pressure distribution in curvilinear flows (a) spillway crest (ii) spillway bucket (14 Marks)

Or

16. Uniform flow occurs in a 3m wide rectangular channel of bed slope 0.003 at a depth of 2.5 m. Due to sedimentation, the channel bed is raised at certain section. Calculate the maximum height of the hump which will cause any change in upstream depth. If the depth of water at upstream is raised to 2.9 m, determine the height of the hump. Take Manning's coefficient as 0.012 (14 Marks)

### Module IV

17. In a wide tidal river, the velocity is 0.75 m/s and the depth of flow is 1.3 m. If a tidal bore is observed to move upstream with a velocity of 4 m/s in this river, determine the velocity and depth of flow after the bore had passed (14 Marks)

Or

18. A steel pipeline is 30 cm in diameter and has a wall thickness of 3 mm. The pipe is 1000 m long and conveys a flow of 100 l/s (Relative density =0.82).The static head at the outlet is 160 m of oil. If the working stress of steel is 0.1 kN/mm<sup>2</sup>, calculate the minimum time of closure of a downstream valve. For oil,  $K=10^9$  Pa and for steel  $E=2.14 \times 10^{11}$  Pa

(14 Marks)

**Module V**

19. (a) Explain Reyleigh's method of dimensional analysis. State its limitations

(8 Marks)

(b) A 1:50 spillway model has a discharge of 1.25 m<sup>3</sup>/s. what is the corresponding prototype discharge ? If a flood phenomenon takes 12 h to occur in the prototype, how long will it in the model ?

(6 Marks)

**Or**

20. A small sphere of density  $\rho_s$  and diameter  $D$  settles at a terminal velocity  $V$  in a liquid of density  $\rho_f$  and dynamic viscosity  $\mu$ . Acceleration due to gravity  $g$  is known to be a parameter Express the functional relationships between these variables in the form

$$\frac{V}{\sqrt{gD}} = f \left[ \frac{\rho_s}{\rho_f}, \frac{\mu}{\rho_f D \sqrt{gD}} \right] \text{ using Buckingham } \pi \text{- theorem} \quad (14 \text{ Marks})$$

Estd.

2014



CET352	ADVANCED CONCRETE TECHNOLOGY	CATEGORY	L	T	P	CREDIT	Year of Introduction
		PEC	3	0	0	3	2019

**Preamble:** This course is aimed at exposing the students to the fundamentals of properties of concrete materials, its testing procedures, various types of concretes, NDT of concrete and mix design. After this course, students will be in a position to determine the properties of concrete materials, testing of concrete and do a mix design based on requirement.

**Prerequisite:** CET309 CONSTRUCTION TECHNOLOGY & MANAGEMENT

**Course Outcomes:**

Course Outcome	Description of Course Outcome	Prescribed learning level
CO 1	To recall the properties and testing procedure of concrete materials as per IS code	Remembering, Understanding
CO 2	To describe the procedure of determining the properties of fresh and hardened concrete	Remembering, Understanding
CO 3	To design concrete mix using IS Code Methods.	Applying & Analysing
CO4	To explain nondestructive testing of concrete	Remembering, Understanding
CO5	To describe the various special types of concretes	Remembering, Understanding

**Mapping of course outcomes with program outcomes (Minimum requirement)**

	PO 1	PO 2	PO 3	PO 4	PO 5	PO 6	PO 7	PO 8	PO 9	PO 10	PO 11	PO 12
CO 1	3	-	-	-	2	2	3	-	-	-	-	-
CO 2	3	-	-	-	2	2	3	-	-	-	-	-
CO 3	3	3	3	2	2	2	3	-	-	-	-	-
CO4	3	-	-	-	2	2	3	-	-	-	-	-
CO5	3	-			3	2	3					

Bloom's Category	Continuous Assessment Tests		End Semester Examination
	1	2	
Remember	20	20	40
Understand	20	20	40
Apply	10	10	20
Analyse			
Evaluate			
Create			

**Mark distribution**

Total Marks	CIE	ESE	ESE Duration
150	50	100	3 hours

**Continuous Internal Evaluation Pattern:**

Attendance	: 10 marks
Continuous Assessment Test (2 numbers)	: 25 marks
Assignment/Quiz/Course project	: 15 marks

**End Semester Examination Pattern:** There will be two parts; Part A and Part B. Part A contain 10 questions with 2 questions from each module, having 3 marks for each question. Students should answer all questions. Part B contains 2 questions from each module of which student should answer any one. Each question carries 14 marks and can have maximum 2 sub-divisions.

**Course Level Assessment Questions**

*(Questions may be framed based on the outline given under each course outcome)*

**Course Outcome 1 (CO1):** To recall the properties and testing procedure of concrete materials as per IS code

1. Discuss the hydration reaction of different cement compounds.
2. List the advantages and disadvantages of artificial aggregates.
3. Explain the classification of aggregates.
4. What are mineral admixtures? Explain GGBS and Flyash.

**Course Outcome 2 (CO2):** To describe the procedure of determining the properties of fresh and hardened concrete

1. What are the factors affecting strength and elasticity of concrete?
2. Define creep. What are the factors affecting creep.

3. Why is cube strength more than cylinder strength in concrete?

**Course Outcome 3 (CO3):** To design concrete mix using IS Code Methods.

1. List the methods available for proportioning concrete mix.
2. Design a concrete mix for any strength from the given data.
3. Write the properties of normal distribution curve. What are its uses in quality control?

**Course Outcome 4 (CO4):** To explain nondestructive testing of concrete

1. State advanced non-destructive testing methods. Explain any one in details.
2. Explain Schmidt's rebound hammer test to assess the strength of concrete.

**Course Outcome 5 (CO5):** To describe the various special types of concretes

1. Write short notes on underwater concreting and mass concreting.
2. Explain step by step procedure to design the Self compacting concrete.
3. Explain basic concept of Fibre reinforced concrete. Give examples of fibres suitable to improve
  - i) flexural strength
  - ii) impact strength
  - iii) shear strength
4. Explain green concrete. State the various materials used in green concrete.

## Syllabus

### Module 1 Concrete materials

**Cement** -Review of manufacturing process- chemical composition, Bogue's compounds, mechanism of hydration-heat of hydration-**Aggregate**-Review of types, sampling and testing, artificial aggregates - **Chemical Admixtures**- types, uses, mechanism of action - effects on properties of concrete - **Mineral admixtures**- types, chemical composition - physical characteristics - effects on properties of concrete - **Rheology** – basic concepts – Bingham model

### Module 2 Mix proportioning

**Mix design** - nominal mix- design mix – concept of mix design - variables of proportioning - general considerations - factors considered in the design of concrete mix- various methods of mix design - design of concrete mix as per IS 10262-2019 - **Statistical quality control of concrete** – mean strength – standard deviation – coefficient of variation – sampling - testing - acceptance criteria

### Module 3 **Properties of fresh and hardened Concrete**

**Properties of fresh concrete**- workability-factors affecting workability - slump test- compaction factor test- Vee Bee consistometer test- **Properties of hardened concrete** - modulus of elasticity, compressive strength, split tensile strength, flexural strength- effect of water cement ratio – maturity concept- **Creep** - factors affecting creep - effect of creep- **Shrinkage**- factors affecting shrinkage - plastic shrinkage, drying shrinkage, autogenous shrinkage, carbonation shrinkage.

### Module 4 **Durability & NDT of concrete**

**Durability of concrete**- Factors affecting durability - permeability- cracking-reinforcement corrosion; carbonation, chloride penetration, sulphate attack, acid attack, fire resistance; frost damage, alkali silica reaction, concrete in sea water - **Non-destructive testing of concrete**- surface hardness test- ultrasonic pulse velocity method - penetration resistance- pull-out test- core cutting - measuring reinforcement cover.

### Module 5 **Special Topics in Concrete Technology**

**Special concretes** - lightweight concrete-heavy weight concrete - high strength concrete – high performance concrete - self compacting concrete -roller compacted concrete– fibre reinforced concrete - polymer concrete-pumped concrete - ready mix concrete - green concrete. **Special processes and technology** - sprayed concrete; underwater concrete, mass concrete; slip form construction, prefabrication technology- 3D concrete printing

#### **Text Books:**

1. Neville A.M., “Properties of Concrete”, Trans-Atlantic Publications, Inc.; 5e, 2016
2. R. Santhakumar „ Concrete Technology“, Oxford Universities Press, 2018
3. Shetty M. S., Concrete Technology“, S. Chand & Co., 2018

#### **Reference Books**

4. Mehta and Monteiro, Concrete-Micro structure, Properties and Materials“, McGraw Hill Professional 2017
5. Neville A. M. and Brooks J. J., Concrete Technology, Pearson Education, 2019
6. Lea, Chemistry of Cement and Concrete“, Butterworth-Heinemann Ltd, 5e, 2017

Module	Topic	Course outcomes addressed	No. of Lectures
<b>1</b>	<b>Module I : Concrete materials Total lecture hours:7</b>		
1.1	Cement -Review of manufacturing process-chemical composition,	CO1	1
1.2	Bogue's compounds, mechanism of hydration-heat of hydration	CO1	1
1.3	Aggregate-Review of types, sampling and testing, artificial aggregates	CO1	1
1.4	Chemical Admixtures- types, uses, mechanism of action - effects on properties of concrete	CO1	1
1.5	- Mineral admixtures- types, chemical composition - physical characteristics - effects on properties of concrete	CO1	1
1.6	Rheology – basic concepts	CO2	1
1.7	Bingham model	CO2	1
<b>2</b>	<b>Module II: Mix proportioning Total lecture hours:7</b>		
2.1	Mix design - nominal mix- design mix – concept of mix design	CO3	1
2.2	Variables of proportioning - general considerations	CO3	1
2.3	Factors considered in the design of concrete mix- various methods of mix design	CO3	1
2.4	Design of concrete mix as per IS 10262-2019	CO3	2
2.6	Statistical quality control of concrete – mean strength – standard deviation	CO3	1
2.7	Coefficient of variation – sampling - testing - acceptance criteria	CO3	1
<b>FIRST INTERNAL EXAMINATION</b>			
	<b>Module III : Properties of fresh and hardened Concrete Total lecture hours: 7</b>		
3.1	Properties of fresh concrete- workability-factors affecting workability -	CO2	1
3.2	Slump test-compaction factor test- Vee Bee consistometer test	CO2	1
3.3	Properties of hardened concrete - modulus of elasticity, compressive strength	CO2	1

3.4	split tensile strength, flexural strength- effect of water cement ratio – maturity concept	CO2	1
3.5	Creep - factors affecting creep - effect of creep	CO2	1
3.6	Shrinkage- factors affecting shrinkage - plastic shrinkage, drying shrinkage	CO2	1
3.7	Autogenous shrinkage, carbonation shrinkage.	CO2	1
<b>4</b>	<b>Module IV: Durability &amp; NDT of concrete Total lecture hours :7</b>		
4.1	Durability of concrete- Factors affecting durability	CO2	1
4.2	Permeability- cracking-reinforcement corrosion; carbonation,	CO2	1
4.3	Chloride penetration, sulphate attack, acid attack, fire resistance	CO2	1
4.4	Frost damage, alkali silica reaction, concrete in sea water	CO2	1
4.5	Non-destructive testing of concrete- surface hardness test	CO4	1
4.6	Ultrasonic pulse velocity method - penetration resistance	CO4	1
4.7	Pull-out test- core cutting - measuring reinforcement cover.	CO4	1
<b>5</b>	<b>Module V:Special Topics in Concrete Technology -Total lecture hours :7</b>		
5.1	Special concretes - lightweight concrete-heavy weight concrete	CO5	1
5.2	High strength concrete – high performance concrete -	CO5	1
5.3	self compacting concrete	CO5	1
5.4	Roller compacted concrete– fibre reinforced concrete - polymer concrete	CO5	1
5.5	Special processes and technology - sprayed concrete; underwater concrete	CO5	1
5.6	mass concrete; slip form construction	CO5	1
5.7	Prefabrication technology- 3D concrete printing	CO5	1

**QP CODE:**

**Reg No.:** \_\_\_\_\_

**Name:** \_\_\_\_\_

**APJ ABDUL KALAM TECHNOLOGICAL UNIVERSITY**  
**SIXTH SEMESTER B.TECH DEGREE EXAMINATION, MONTH & YEAR**

**Course Code: CET352**

**Course Name: ADVANCED CONCRETE TECHNOLOGY**

Max. Marks: 100

Duration: 3 hours

**Part A**

*(Answer all questions; each question carries 3 marks)*

1. What are the properties of Bogue's compound?
2. What is the role of chemical admixtures in concrete?
3. Describe the factors considered in mixture proportioning.
4. Explain statistical quality control measures of concrete.
5. What is meant by shrinkage of concrete?
6. What are the factors affecting workability of concrete?
7. Describe the effect of fire on concrete.
8. Explain the pull-out test on concrete.
9. Write short notes on underwater concreting?
10. What are the applications of roller compacted concrete?

**PART B**

*(Answer one full question from each module, each question carries 14 marks)*

11. (a). Explain concrete flow behaviour using a Bingham model. (6 Marks)  
(b). Describe the influence of mineral admixtures in concrete. Explain any two mineral admixtures in detail. (8 Marks)

OR

12. (a) Describe various tests for determining the quality of aggregate to be used for concreting work. (7 Marks)  
(b) Discuss the hydration reaction of different cement compounds. (7 Marks)

13. Design a concrete mix for the following data.

Grade of concrete: M25, cement of 43 grade, moderate exposure, Zone III sand, compaction factor 0.9, 20mm maximum sized rounded aggregate. (14 marks)

OR

CIVIL ENGINEERING

14. (a) Write down the procedure for concrete mix design by IS method. (8 Marks)  
(b) Explain different methods of mix design. (6 Marks)
15. (a) Explain the factors affecting the strength of concrete. (7 Marks)  
(b) Explain the procedure of determining flexural strength of concrete under four point bending (7 Marks)

OR

16. (a) Explain the procedure for determining modulus of elasticity of concrete. (7 Marks)  
(b) Explain the term creep, its effects and factors affecting creep. (7 marks)
17. (a) Explain the sulphate attack on concrete and explain the effect of sea water in concrete. (6 Marks)  
(b) Explain any two non-destructive tests in concrete. (8 marks)

OR

18. (a). Discuss the causes of corrosion of steel in concrete. (8 Marks)  
(b) What is meant by reinforcement cover? How is it measured? (6 Marks)
19. (a) Explain any two methods for testing fresh stage properties of self-compacting concrete. (8 Marks)  
(b) Explain green concrete. (6 Marks)

OR

20. (a) What is the influence of prefabrication technology on modern construction industry (8 Marks)  
(b) Describe sprayed concrete. (6 Marks)





CET 362	ENVIRONMENTAL IMPACT ASSESSMENT	CATEGORY	L	T	P	CREDIT	Year of Introduction
		PEC	3	0	0	3	2019

**Preamble :** This course introduces the methodologies for identifying, predicting, evaluating and mitigating the impacts on environment due to any developmental project or activities. Students will learn how to prepare an impact assessment report and devise an environment management plan. Sufficient background will be provided on the environmental clearance procedures in India.

**Prerequisite:** NIL

**Course Outcomes :** After the completion of the course the student will be able

Course Outcome	Description of Course Outcome	Prescribed learning level
CO1	To appreciate the need for minimizing the environmental impacts of developmental activities	Understanding
CO2	To understand environmental legislation & clearance procedure in the country	Remembering, Understanding
CO 3	To apply various methodologies for assessing the environmental impacts of any developmental activity	Applying &Analysing
CO 4	To prepare an environmental impact assessment report	Analysing& Evaluating
CO 5	To conduct an environmental audit	Analysing &Evaluating

**Mapping of course outcomes with program outcomes (Minimum requirement)**

	PO 1	PO 2	PO 3	PO 4	PO 5	PO 6	PO 7	PO 8	PO 9	PO 10	PO 11	PO 12
CO 1	-	-	-	-	-	2	2	-	-	-	-	-
CO 2	-	-	-	-	-	2	-	-	-	-	-	-
CO 3	2	-	-	3	2	-	3	-	-	-	-	-
CO4	-	-	-	2	-	2	2	3	-	3	-	-
CO5	-	-	-	2	1	-	2	2	-	2	-	-

**Assessment Pattern**

Bloom's Category	Continuous Assessment Tests		End Semester Examination
	1	2	
Remember	10	10	15
Understand	10	10	15
Apply	15	15	35
Analyse	15	15	35
Evaluate			
Create			

**Mark distribution**

Total Marks	CIE	ESE	ESE Duration
150	50	100	3 hours

**Continuous Internal Evaluation Pattern:**

Attendance : 10 marks  
 Continuous Assessment Test (2 numbers) : 25 marks  
 Assignment/Quiz/Course project : 15 marks

**End Semester Examination Pattern:** There will be two parts; Part A and Part B. Part A contain 10 questions with 2 questions from each module, having 3 marks for each question. Students should answer all questions. Part B contains 2 questions from each module of which student should answer any one. Each question carries 14 marks and can have maximum 2 sub-divisions.

**Course Level Assessment Questions**

**CO1: To be able to appreciate the need for minimizing the environmental impacts of developmental activities**

1. Explain the evolution of EIA in India
2. Explain why EIA is needed for developmental projects.
3. What are the different ways in which development projects impact the water quality and quantity?

**CO 2: To be able to understand environmental legislation & clearance procedure in the country**

1. Two municipalities in Kerala plan to set up a Common Municipal Solid Waste Management Facility (CMSWMF). Explain the procedure required for the Environmental Clearance (EC) for the project as per the EIA Notification of 2006. (All CMSWMFs are category B projects)
2. Describe the procedure for obtaining environmental clearance according to EIA notification 2006.
3. The Environment (Protection) Act, 1986 is called an umbrella legislation. Substantiate the statement.

**CO3: To be able to apply various methodologies for assessing the environmental impacts of any developmental activity**

1. Prepare a simple checklist for assessment of socio economic impact due to the development of a highway.
2. Explain overlay mapping as an EIA method
3. Explain how to predict the impact of a highway project on air quality

**CO4: To be able to prepare an environmental impact assessment report**

1. Explain the Terms of Reference (ToR) for EIA report of a highway project
2. Explain the structure of EIA report
3. Explain the importance of an environmental management plan.

**CO5: To be able to conduct an environmental audit**

1. Explain the need for environmental auditing
2. What are the different types of environmental audits?
3. Explain the importance of ISO 14001 standard.

**SYLLABUS****Module 1**

Definition, Need for EIA, Evolution of EIA: Global & Indian scenario -Environmental legislations in India- The Water (Prevention & Control of Pollution) Act 1974, The Air (Prevention & Control of Pollution) Act 1981, The Environmental (Protection) Act 1986- Environmental standards for water, air and noise quality- EIA Notification 2006

**Module 2**

Environmental clearance process in India: Screening, Scoping, Public Consultation, Appraisal- Form 1-Category of projects- Generic structure of EIA report- Terms of Reference (ToR) -Types of EIA: strategic, regional, sectoral, project level- Rapid EIA and Comprehensive EIA- Initial Environmental Examination (IEE)

**Module 3**

EIA methodologies: Ad hoc, checklist, matrix, network and overlay- Impact Prediction, Evaluation and Mitigation- Prediction and assessment of the impact on water (surface water and groundwater), air, and noise environment- assessment of ecological impacts and Socio economic Impacts.

**Module 4**

Environmental Management Plan (EMP): Goal and purpose- Importance of EMP- Content of an EMP- Role of environmental monitoring program

Environment Audit: need for audit- audit types and benefits- environmental audit procedure

ISO 14001 standards: Importance, salient features - Stages in implementation- Benefits

**Module 5**

EIA case studies (Indian)- a highway project, a hydro electric power plant, an air port project, a quarry mining project and a solid waste management project

**Text Books:**

1. Larry W Canter, "Environmental Impact Assessment", McGraw Hill Inc. , New York, 1995
2. Betty Bowers Marriott, Environmental Impact Assessment: A Practical Guide, McGraw-Hill Professional, 1997
3. Environmental Impact Assessment, 2003, Y.Anjaneyulu, B.S Publications

**References:**

1. Lawrence, David P., Environmental Impact Assessment (Practical Solutions to Recurrent Problems), Wiley International, New Jersey.
2. Ministry of Environment & Forests, Govt. of India 2006 EIA Notification
3. Jain, R.K., Urban, L.V. and Stacey, G.S., Environment Impact Analysis, Von Nostrand Reinhold Company.

**Lecture Plan- Environmental Impact Assessment**

<b>Module</b>	<b>Topic</b>	<b>Course Outcomes addressed</b>	<b>No. of Lectures</b>
<b>1</b>	<b>Module 1: Total Lecture Hours -7</b>		
1.1	Definition, Need for EIA, Evolution of EIA: Global & Indian scenario	CO1	1
1.2	Environmental legislations in India- The Water (Prevention & Control of Pollution) Act 1974, The Air (Prevention & Control of Pollution) Act 1981, The Environmental (Protection) Act 1986	CO2	3
1.3	Environmental standards for water, air and noise quality	CO2	1
1.4	EIA Notification 2006	CO2	2
<b>2</b>	<b>Module II: Total Lecture Hours-7</b>		
2.1	Environmental clearance process in India: Screening, Scoping, Public Consultation, Appraisal- Form1- Category of projects	CO2	3
2.2	Generic structure of EIA report- Terms of Reference (ToR)	CO4	1
2.3	Types of EIA: strategic, regional, sectoral, project level-	CO3	1
2.4	Rapid EIA and Comprehensive EIA	CO3	1
2.5	Initial Environmental Examination (IEE)	CO3	1
<b>3</b>	<b>Module III: Total Lecture Hours-7</b>		
3.1	EIA methodologies: Ad hoc, checklist, matrix, network and overlay	CO3	3
3.2	Impact Prediction, Evaluation and Mitigation- Prediction and assessment of the impact on water (surface water and groundwater), air, and noise	CO3	2

	environment		
3.3	assessment of ecological impacts and Socio economic Impacts	CO3	2
<b>4</b>	<b>Module IV: Total Lecture Hours- 7</b>		
4.1	Environmental Management Plan (EMP): Goal and purpose- Importance of EMP- Content of an EMP	CO4	2
4.2	Role of environmental monitoring program	CO4	1
4.3	Environment Audit: need for audit- audit types and benefits- environmental audit procedure	CO5	2
4.4	ISO 14001 standards: Importance, salient features - Stages in implementation- Benefits	CO5	2
<b>5</b>	<b>Module V: Total Lecture Hours- 7</b>		
5.1	EIA case studies (Indian)- a highway project	CO1, CO4	2
5.2	Hydro electric power plant, air port project	CO1, CO4	3
5.3	Quarry mining project, solid waste management project	CO1, CO4	3



**Model Question Paper**

Reg No.: \_\_\_\_\_

Name: \_\_\_\_\_

**APJ ABDUL KALAM TECHNOLOGICAL UNIVERSITY**  
**SIXTH SEMESTER B.TECH DEGREE EXAMINATION**

**Course Code: CET362**

**Course Name: ENVIRONMENTAL IMPACT ASSESSMENT**

Max. Marks: 100

Duration: 3 Hours

**Part A**

*(Answer all questions; each question carries 3 marks)*

1. Explain the need for EIA
2. Why environmental (protection) act, 1986 is called an umbrella act?
3. Discuss screening of projects
4. What is rapid EIA?
5. What is ad hoc method for impact assessment?
6. How to predict the impact of a proposed food industry on the water quality of a nearby river
7. Explain the benefits of an environmental audit
8. What is ISO 14001 standard?
9. What are the impacts of a highway project on local air quality
10. Discuss the environment monitoring program for a quarry mining industry.

**PART B**

*(Answer one full question from each module, each question carries 14 marks)*

11. (a) Discuss environmental standards for water, air and noise (6 Marks)  
 (b) Discuss evolution of EIA in India (8 Marks)
- OR
12. (a) Discuss Air (Prevention & Control of Pollution) Act 1981 (5 Marks)  
 (b) Explain salient features of EIA notification 2006 (9 Marks)
13. (a) Discuss environmental clearance process in India (10 Marks)  
 (b) What is Form-1 ? (4 Marks)

OR

14. (a) What is Initial Environmental Examination? (5 Marks)  
(b) Explain different types of EIA (9 Marks)

15. (a) Discuss in detail EIA methodologies (10 Marks)  
(b) How can air quality modelling help in assessing the impact on air (4 Marks)

OR

16. (a) Explain the steps to assess the impacts on the ecological environment due to a project (7Marks)  
(b) Explain the steps involved in assessment of impacts on the water environment. (7 Marks)

17. (a) What are the different types of Environmental Audit? (5 Marks)  
(b) Discuss the content of an environment management plan (9 marks)

OR

18. (a) Discuss the salient features of an Environmental Monitoring Plan (5 Marks)  
(b) Explain in detail the procedure for conducting an environmental audit (9 Marks)

19. Explain environmental clearance procedure for an airport (14 Marks)

OR

20. Discuss how to assess the impacts of a hydro electric project (14 Marks)





CET372	FUNCTIONAL DESIGN OF BUILDINGS	Category	L	T	P	Credit	Year of Introduction
		PEC	3	0	0	3	2019

**Preamble:** The general objective of this course is to provide an insight to the students to various aspects of functional design of buildings and innovative construction methods.

**Pre-requisite:** CE204 Construction Technology

**Course outcome :** After the course, the student will able to:

CO1	Develop an understanding of acoustical design and noise control techniques
CO2	Understand elemental concepts of natural and artificial lighting designs
CO3	Know the principles involved in the design of buildings for thermal comfort and influence of climate on design of buildings
CO4	Have basic concept for electrical load calculation, plumbing design, HVAC load Calculation, functioning of elevators and escalators and rough cost estimation.
CO5	Acquire knowledge of innovative construction concepts

CET372	Functional Design of Buildings		PO 1	PO 2	PO3	PO4	PO5	PO6	PO7	PO8	PO9	PO10	PO11	PO12	
		CO1	3	3											
		CO2	3	3											
		CO3	3	3											
		CO4	3	3											
		CO5	3	3											

**Assessment pattern**

Bloom's Category	Continuous Assessment Tests		End Semester Examination (Marks)
	Test 1 (Marks)	Test 2 (Marks)	
Remember	5	5	15
Understand	10	10	15
Apply	20	20	40
Analyze	15	15	30
Evaluate			
Create			

**Continuous Internal Evaluation Pattern:**

Attendance	:	10marks
Continuous Assessment Test (2numbers)	:	25 marks
Assignment/Quiz/Course project	:	15marks
<b>Total</b>	:	<b>50marks</b>

**End semester examination pattern** – There will be two parts; Part A and Part B. Part A contain 10 questions with 2 questions from each module, having 3 marks for each question. Students should answer all questions. Part B contains 2 questions from each module of which student should answer any one. Each question can have maximum 2 sub-divisions and carry 14marks.

**Course Level Assessment Questions**

*(Questions may be framed based on the outline given under each course outcome)*

## Course Outcome 1 (CO1)

1. Develop an understanding of acoustical design and noise control techniques
2. Applications of acoustics
3. Explain the acoustical considerations for offices, hospitals and industrial buildings

## Course Outcome 2 (CO2)

1. Explain the purposes of lighting
2. Explain the basic concepts of natural and artificial lighting
3. Explain the different methods used for the design of natural lighting
4. Explain the different methods used for the design of artificial lighting

## Course Outcome 3 (CO3)

1. Evaluate the principles involved in the design of buildings for thermal comfort
2. Explain the influence of climate on design of buildings
3. Compute solar radiation on different surfaces
4. Describe thermo physical properties of buildings

## Course Outcome 4 (CO4)

1. Describe the basic concepts for electrical load calculation of structures
2. Explain the basic criteria for plumbing design
3. Calculation of HVAC load
4. Explain the functioning of elevators and escalators
5. Understand the rough cost estimation

## Course Outcome 5 (CO5)

1. Understand traditional techniques in Tropical climate with vernacular buildings in Kerala
2. Explain the concepts of green building
3. Describe concepts for intelligent buildings
4. Explain innovative construction methods

**Course Code: CET 372**

**FUNCTIONAL DESIGN OF BUILDINGS**

**Syllabus**

### Module I

**Acoustical / Sonic Environment and acoustical comfort:** Sound, Nature of sound- Behavior of sound in enclosed spaces-Concept of Geometric Acoustics-Reflection of sound and their applications- Absorption of sound-Sound absorption coefficient-Human Audibility range-Reverberation & Reverberation Time Calculation- Flanking paths- Sound absorption-materials and fixings- Reverberation-Sabine's formula-Eyrings modification.-Basic design of the elements for the required degree of sound insulation- Air and structure born noises-equivalent noise levels-day and night equivalent.

**Acoustics, applications:** Measures of noise control- Source-path and receiving end. TL value and computation of TL value, Acoustical defects- acoustical design of auditoriums and small lecture halls-Acoustical considerations of offices, hospitals and Industrial buildings.

### Module II

**Natural lighting:** Visual task requirements, Units of Light, Light, Vision and Buildings, Standards of Lighting and Visual comfort-The sky as a source of light, Daylight factor, Daylight penetration- Calculation of daylight factor. Design of side-lit windows-BIS and CBRI methods-skylights

**Artificial lighting:** Artificial lighting- illumination requirements-lux meter – lamps and luminaries – polar distribution curves– Color temperature and color rendering index- glare - Design of artificial lighting – lumen method – point by point method. Basic idea of street lighting and outside lighting

### Module III

**Thermal comfort:** Factors affecting thermal comfort- effective temperature- thermal comfort indices-ET-CET Charts- Bioclimatic chart- Psychrometry and Psychrometric chart.

**Earth-Sun relationship:** Sun's apparent movement with respect to the earth. Solar angles- Computation of solar radiation on different surfaces-solar path diagram-shadow-throw concept and design of shading devices

**Thermal design of buildings:** Thermo physical properties of building materials and thermal control: passive and active building design- Steady and periodic heat flow through building envelope.

**Design approaches:** Climate conscious designs- Climatic zones in India- orientation and shape of buildings in different climatic zones- Passive solar-Active solar and Active approaches. Requirements of buildings in tropical areas-Thermal insulation

### Module IV

**Functional elements:** Concept for electrical load calculation of structures- basic criteria for plumbing design – basic concept of HVAC load calculation – Basic concept of functioning of elevators and escalators- basic cost estimation.

**Functional protection:** Causes of fire, Mechanism of fire spread in buildings, classification of fire-High temperature effects and combustibility of building materials and structure- Fire alarm system, and means of escape-Firefighting installations.

### Module V

**Functionality as per Vastusastra:** Basic concepts- Governing criteria of functionality- Energy pattern- understand traditional techniques in Tropical climate with vernacular buildings in Kerala as case study.

**Innovative concepts of functionality:** Concept of green building- case studies on low energy and green buildings-Concepts of Intelligent building- Thirsty concrete- Blue roads- self healing concrete

**Text Books and References:**

1. Knudsen V.O. and Harris C.M., Acoustical Design in Architecture, John Wiley,1980
2. M David Egan , Architectural Acoustics, J.Ross Publishing,2007
3. Marshall Long, “Architectural Acoustics”, Second Edition, Academic Press, Waltham, USA, 2014
4. Bureau of Indian standards, Handbook on Functional Requirement of Buildings – SP:41(S and T)-1987
5. Pritchard, D.C., "Lighting", Longman Scientific & Technical, Harlow,1995.
6. Benjamin Evans, "Daylight in Architecture", McGraw - Hill Book Company, Newyork,1981.
- 7.Koenigseberger, Manual of tropical Housing and Building Part I – Climatic design, Orient Longman,2011
8. AjithaSimha.D, Building Environment, Tata McGraw Hill Publishing Co., New Delhi,1985
9. Jain. V.K., "Design and Installation of Services in Building complexes &High Rise Buildings", Khanna Tech. Publishers, New Delhi,1986.
10. National Building Code of India (NBC2016)
11. Wayne Forster and Dean Hawkes, “Energy Efficient Buildings: Architecture, Engineering, and Environment”. W.W. Norton Company Inc.2002.
12. Bureau of Energy Efficiency, India. Design Guidelines for Energy Efficient Multi-Storey Buildings,2014.



<b>Module</b>	<b>Topic</b>	<b>Course outcome addressed</b>	<b>No of Hours</b>
<b>Module I (8 Hours)</b>			
1.1	Acoustical / Sonic Environment and acoustical comfort: Sound, Nature of sound- Behavior of sound in enclosed spaces	CO1	1
1.2	Concept of Geometric Acoustics-Reflection of sound and their applications- Absorption of sound-Sound absorption coefficient-	CO1	1
1.3	Human Audibility range-Reverberation & Reverberation Time Calculation- Flanking paths. Sound absorption-materials and fixings. Reverberation-Sabine's formula-Eyrings modification.	CO1	2
1.4	Basic design of the elements for the required degree of sound insulation- Air and structure born noises-equivalent noise levels- day and night equivalent	CO1	1
1.5	Acoustics, applications: Measures of noise control- Source-path and receiving end. TL value and computation of TL value, Acoustical defects-	CO1	1
1.6	Acoustical design of auditoriums and small lecture halls. Acoustical considerations of offices, hospitals and Industrial buildings.	CO1	2
<b>Module II (6 Hours)</b>			
2.1	Natural lighting: Visual task requirements, Units of Light, Light, Vision and Buildings	CO2	1
2.2	Standards of Lighting and Visual comfort-The sky as a source of light, Daylight factor, Daylight penetration-Calculation of daylight factor.	CO2	1
2.3	Design of side-lit windows-BIS and CBRI methods-skylights	CO2	1
2.4	Artificial lighting: Artificial lighting- illumination requirements- lux meter – lamps and luminaries – polar distribution curves	CO2	1
2.5	Color temperature and color rendering index- glare - Design of artificial lighting – lumen method – point by point method. Basic idea of street lighting and outside lighting	CO2	2
<b>Module III (8Hours)</b>			

3.1	Thermal comfort: Factors affecting thermal comfort- effective temperature	CO3	1
3.2	Thermal comfort indices-ET-CET Charts- Bioclimatic chart- Psychrometry and Psychrometric chart.	CO3	1
3.3	Earth-Sun relationship: Sun's apparent movement with respect to the earth. Solar angles	CO3	1
3.4	Computation of solar radiation on different surfaces-solar path diagram-shadow-throw concept and design of shading devices	CO3	1
3.5	Thermal design of buildings: Thermo physical properties of building materials and thermal control- Passive and active building design- Steady and periodic heat flow through building envelope.	CO3	1
3.6	Design approaches: Climate conscious designs- Climatic zones in India-orientation and shape of buildings in different climatic zones	CO3	2
3.7	Passive solar-Active solar and Active approaches. Requirements of buildings in tropical areas-Thermal insulation	CO3	1
<b>Module IV (7 Hours)</b>			
4.1	Functional elements: Concept for electrical load calculation of structures	CO4	1
4.2	Basic criteria for plumbing design	CO4	1
4.3	Basic concept of HVAC load calculation	CO4	1
4.4	Functional protection: Causes of fire, Mechanism of fire spread in buildings, classification of fire-High temperature effects and combustibility of building materials and structure- Fire alarm system, and means of escape. Firefighting installations	CO4	2
4.5	Basic concept of functioning of elevators and escalators and basic cost estimation of services.	CO4	2
<b>Module V (6Hours)</b>			
5.1	Functionality as per Vastusastra: Basic concepts- Governing criteria of functionality - Energy pattern	CO5	1
5.2	Understand traditional techniques in Tropical climate with vernacular buildings in Kerala as case study	CO5	2
5.3	Innovative concepts of functionality: Concept of green building- case studies on low energy and green buildings-	CO5	2
5.4	Concepts of Intelligent building- Thirsty concrete- Blue roads- self healing concrete	CO5	1

**MODEL QUESTION PAPER**

Reg. No.: \_\_\_\_\_

Name: \_\_\_\_\_

**APJ ABDUL KALAM TECHNOLOGICAL UNIVERSITY**  
SIXTH SEMESTER B.TECH DEGREE EXAMINATION, MONTH & YEAR

**Course Code: CET372****Course Name: FUNCTIONAL DESIGN OF BUILDINGS**

Max.Marks: 100

Duration: 3hours

**Part A**

(Answer all questions; each question carries 3 marks)

1. Write briefly about the audibility range of human beings. (3 Marks)
2. Discuss any three common acoustical defects seen in an auditorium. (3 Marks)
3. What are the advantages and disadvantages of sky lighting? (3 Marks)
4. Briefly describe polar distribution curves (3 Marks)
5. What are the thermal insulating materials used to maintain comfortable conditions inside a building? (3 Marks)
6. What do you understand by the following (i) Solar Constant (ii) Solar Azimuth (iii) Solar Altitude (3 Marks)
7. Write short note on "Handling capacity of Lifts" (3 Marks)
8. Briefly describe firefighting installations (3 Marks)
9. Describe self healing concrete. (3 Marks)
10. List out the advantages of self healing concrete. (3 Marks)

**PART B**

(Answer one full question from each module, each question carries 14 marks)

**Module – 1**

11. (a) TL value of a  $16\text{m}^2$  solid wall is 45 dB. If a hole of  $2\text{ cm}^2$  is drilled through it, find the reduction in TL value? (10 Marks)
- (b) Discuss how the TL value of a separating wall varies with its mass. (4 Marks)
12. (a) Explain how sound intensity varies with distance from a point source



- I. In free field
- II. In a reverberant field (8 Marks)
- (b) What you mean by Acoustical Day Time and Acoustical Night Time. Explain the concepts of  $L_{eq}$  and  $L_{dn}$ ? (6Marks)

### Module – 2

13. (a) Explain the procedure of design of Artificial lighting by Lumen Method. (7 Marks)
- (b) A point source of light has an intensity 2000 candela in the vertically downward direction. The intensity reduces with the angle and reaches 1000 cd at the horizontal direction (90degrees with vertical). If the source is mounted 4m above the working plane, find the illumination due to this light source at points (i) directly under the lamp (ii) at 3m away in the same plane. (7 Marks)
14. (a) Define the different components of daylight factor? (6 Marks)
- (b) What do you understand by the concepts Passive solar design, Active solar design and active design? (8 Marks)

### Module – 3

15. (a) Explain the considerations to be made in achieving thermal comfort in hot & dry and Warm and humid regions? (7 Marks)
- (b) Explain the concept of shadow angles and shadow throws. How shadow throws are used in the design of shading devices? (7 Marks)
16. (a) Explain the concept of comfort zone based on Bio-climatic chart (7 Marks)
- (b) What is Psychrometry? What are the usual input parameters to a Psychrometric chart? What are the various informations we get from a Psychrometric chart? (7 Marks)

### Module – 4

17. Explain the features, operation arrangements, location and types of Elevators in public buildings. (14 Marks)
18. Explain the high temperature effects and combustibility of building materials and structures (14Marks)

**Module – 5**

19. (a) Explain the concepts of green building. (7 Marks)  
(b) Describe LEED and GRIHA ratings for the evaluation of green buildings. (7 Marks)
20. Describe the modern construction materials and its merits (14 Marks)

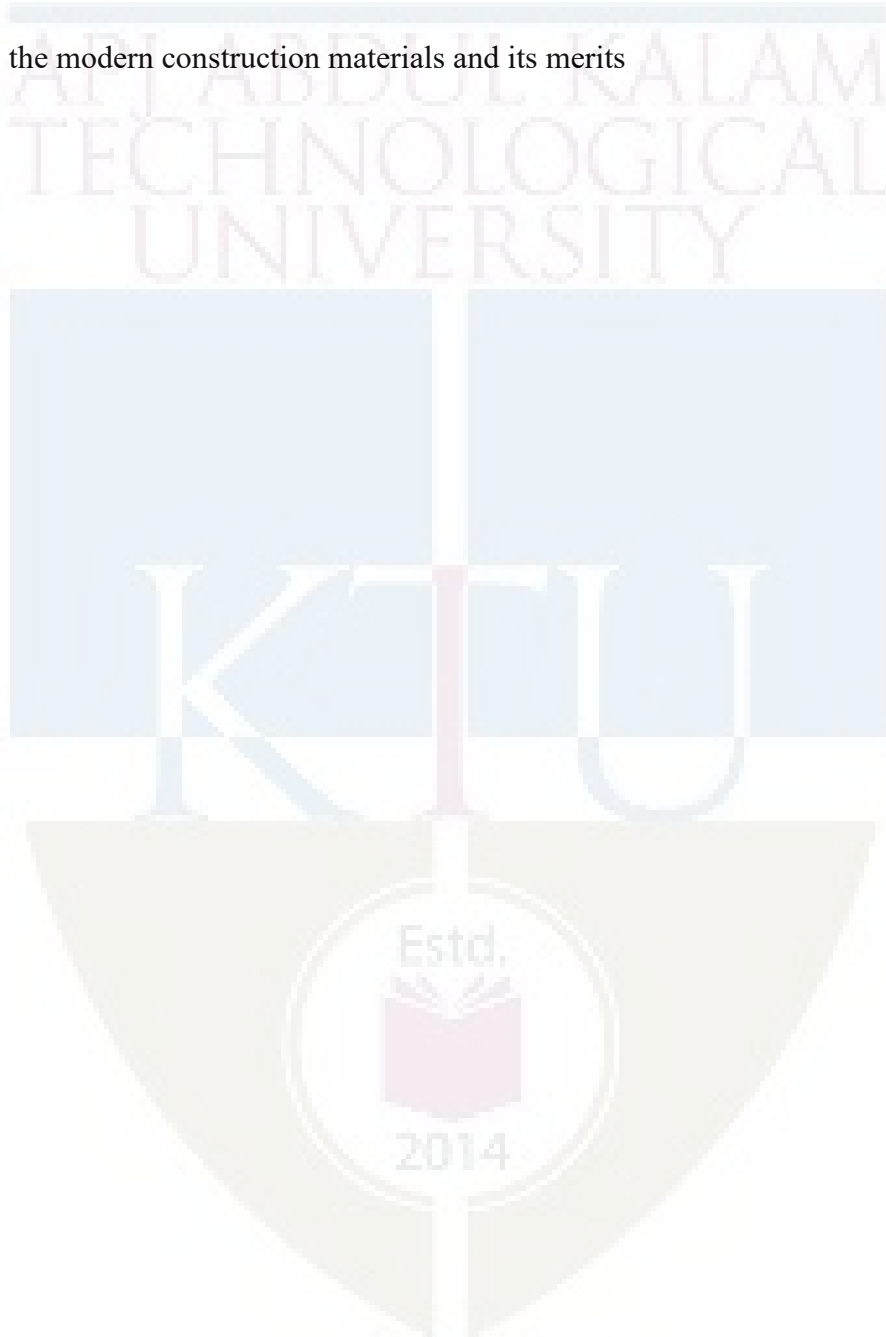

APJ ABDUL KALAM  
TECHNOLOGICAL  
UNIVERSITY

**SEMESTER VI**

**MINOR**





**Assessment Pattern**

Bloom's Category	Continuous Assessment Tests		End Semester Examination
	1	2	
Remember			
Understand	20	10	35
Apply	30	10	40
Analyse		30	25
Evaluate			
Create			

**Mark distribution**

Total Marks	CIE	ESE	ESE Duration
150	50	100	3 hours

**Continuous Internal Evaluation Pattern:**

Attendance : 10marks  
 Continuous Assessment Test(2numbers) : 25  
 marksAssignment/Quiz/Courseproject : 15marks

**End Semester Examination Pattern:** There will be two parts; Part A and Part B. Part A contain 10 questions with 2 questions from modules 1 to 3 and 4 questions from module 4, having 3 marks for each question. Students should answer all questions. Part B contains 2 questions from each module of which student should answer any one. Each full question carries 16 marks from module 1, 2 and 4 and 22 marks from module 3 and can have maximum 2 sub- divisions.

**Note:** For analysis of rate and cost estimation, unit rate and labour requirement should be given along with the questions in the question paper. No other charts, tables, codes are permitted in the Examination Hall. If necessary, relevant data shall be given along with the question paper.

**Course Level Assessment Questions**

**CO1:** Explain the specifications for various items of work associated with building construction

1.	Write the detailed specification of earth work in excavation
2.	Differentiate general specification and detailed specification with suitable example

**CO2:** Analyse the unit rates of different items of work associated with building construction

1.	Explain DAR and DSR.
2.	<p>Develop rate analysis for DSR item No.5.3, Reinforced cement concrete work with 1:1.5:3 (3 graded stone aggregate 20 mm nominal size) in beams, suspended floors, roofs having slope up to 15° landings, above plinth level up to floor five level, excluding the cost of centering, shuttering, finishing and reinforcement.</p> <p><b>Material:</b> 20mm Aggregate 0.57m<sup>3</sup>@₹1300/m<sup>3</sup>, 10mm 0.28m<sup>3</sup>@ ₹1300/m<sup>3</sup>, coarse sand (Zone III) 0.425m<sup>3</sup>@₹1200/m<sup>3</sup>, Portland cement 400kg@₹5700/tonne.</p> <p><b>Labour :</b> Mason 0.24@₹467/day, Beldar 2.75@₹368/day, Bhisti 0.90@₹407/day, Coolie 1.88@₹368/day</p> <p><b>Carriage provisions:</b> Stone aggregate below 40mm 0.85m<sup>3</sup>@₹103.77, Portland cement 0.40tonne@₹5700/tonne.</p> <p><b>Hire Charges</b> for concrete mixer 0.08@₹800/day, Vibrator needle type ₹0.08@350/day</p> <p><b>Sundries (LS)</b> 14.30@₹1.73. Adopt water charges, contractor profit and overheads as per the CPWD DSR2018 provisions.</p>

**CO3:** Prepare the approximate estimate of building

1.	Differentiate plinth area estimate and cubic content estimate
2.	<p>Prepare the approximate estimate of building project with total plinth area of all building is 800sqm from the following data</p> <ol style="list-style-type: none"> <li>Plinth area rate₹. 45000 per sqm</li> <li>Cost of water supply @7.5% of cost of building</li> <li>Cost of sanitary and electrical installations each @ 7.5% of cost of building</li> <li>Cost of architectural features @ 1% of cost of building</li> </ol>

<p>e) Cost of roads and lawns @5% of cost of building</p> <p>f) Cost of PS and contingencies @4% of cost of building</p> <p>Determine the total cost of building project</p>
------------------------------------------------------------------------------------------------------------------------------------------------------------------------------

**CO4:** Prepare detailed estimates of buildings and the bar bending schedules for R.C.C works

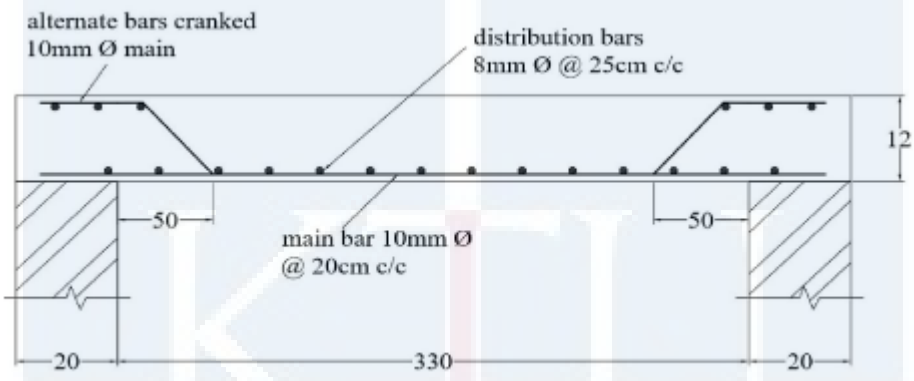
1.	Explain bar bending schedule. State its uses
2.	Write the unit of measurement of (i) Carpentry fittings (ii) Pointing of Brick wall
3.	<p>Calculate the quantity of RCC and Prepare a bar bending schedule of the slab of size 330cm x 550cm (internal dimensions) shown in the figure. (All dimensions are in centimeters)</p>  <p>alternate bars cranked 10mm Ø main</p> <p>distribution bars 8mm Ø @ 25cm c/c</p> <p>main bar 10mm Ø @ 20cm c/c</p> <p>12</p> <p>50</p> <p>50</p> <p>20</p> <p>330</p> <p>20</p>
4.	<p>Prepare detailed estimate for the following items of work for the construction of residential building shown below</p> <ol style="list-style-type: none"> <li>RRM for foundation and basement</li> <li>RCC works</li> <li>Inside and outside plastering</li> </ol>

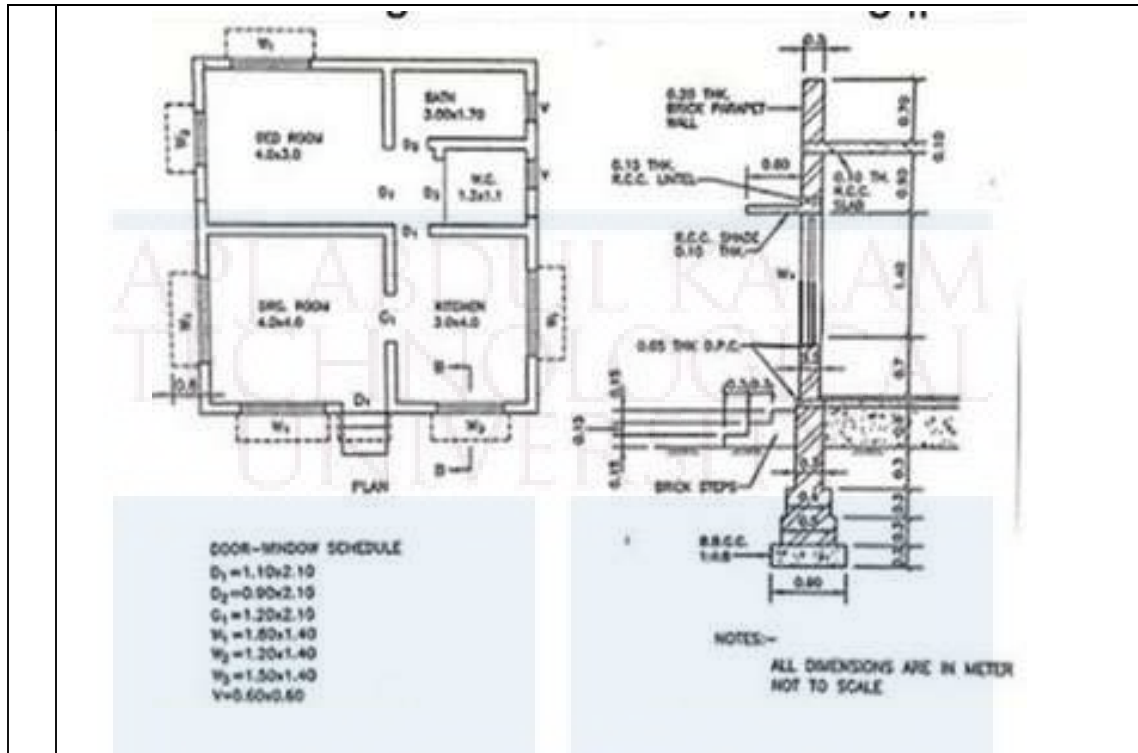

**C05:** Describe various principles and methods of valuation

1.	Explain how depreciation in building is worked out.
2.	Discuss about the different types of values and the term obsolescence
3.	Discuss the importance of valuation in civil engineering.

**C06:** Calculate the value of buildings by different methods

1.	A building is situated by the side of a main road of Mumbai city on a land of 500sqm. The built up portion is 20m x 15 m. The building is first class type and provided with water supply, sanitary and electrical fittings, and the age of the building is 30 years. Work out the valuation of the property.
2.	A three storied building is standing on a plot of land measuring 800sqm. The plinth area of each storey is 400sqm. There is an RCC framed structure and the future life may take as 70 years. The building fetches a gross rent of ₹.18000 per month, Work out the capitalized value of the property on the basis of 6% net yield. For sinking fund 3% compound interest may be assumed. Cost of the land may be taken as ₹. 10000 per sqm. The other data may assume suitably



- |    |                                                                                                                                                                                                                                                                                                                                                                                                                                                                                                                                                                                                                                                                                                      |
|----|------------------------------------------------------------------------------------------------------------------------------------------------------------------------------------------------------------------------------------------------------------------------------------------------------------------------------------------------------------------------------------------------------------------------------------------------------------------------------------------------------------------------------------------------------------------------------------------------------------------------------------------------------------------------------------------------------|
| 3. | Workout the valuation of a commercial building with the following data: Cost of land for life-time period of building is ₹.5,20,000/-. Gross income per year is ₹.8,50,000/-Expenses required per year: (a) staff salary, electric charges, municipal taxes including licenses fees, stationery and printing etc. is 20% of the gross income. (b) For repair and maintenance of lift, furniture etc. @ 5% of their capital cost of ₹.10,50,000/- (c) sinking fund for the items considered in capital cost, whose life is 25years @4% after allowing 10% scrap value. (d) Insurance premium is ₹.25, 000/- per year. Take year's purchase @8% and annual repair of the building @2% on gross income. |
|----|------------------------------------------------------------------------------------------------------------------------------------------------------------------------------------------------------------------------------------------------------------------------------------------------------------------------------------------------------------------------------------------------------------------------------------------------------------------------------------------------------------------------------------------------------------------------------------------------------------------------------------------------------------------------------------------------------|

## SYLLABUS

**MODULE 1.** General introduction- Quantity surveying- Basic principles, Types of Estimates- purposes, Specifications-General & detailed specification for building materials and execution of major item of work (Earth work excavation, masonry, concrete, finishing) of building work with reference to CPWD specifications-Method of measurement with reference to IS1200.

**MODULE 2.** Analysis of rates, Introduction to the use of CPWD schedule of rates as per latest DSR and Analysis of rate as per latest DAR, Overhead charges. Analysis of rates for Earth work in excavation for foundation, mortars, reinforced cement concrete Works, finishing work, masonry work, stone works, flooring with reference to latest DSR and latest DAR .Types of tender, contracts, General and important conditions of contract, contract document(concept only). Duties and roles of client, architect/engineer, contractor and local bodies.

**MODULE 3.** Detailed Estimate- Preparation of detailed measurement and abstract of estimate using Centreline method & Long wall short wall(separate wall) method for RCC single storey building, (students may answer the question by using any of the two methods)Septic tank and Soak Pit, preparation of Bar Bending Schedule– lintel, beams, slabs, RCC column footings.

**MODULE 4.** Valuation – explanation of different technical terms, purpose. Depreciation – methods of calculating depreciation – straight line method, constant percentage method, sinking fund method and quantity survey method, obsolescence.

Principles of valuation of open land- comparative method, abstractive method, belting method, valuation based on hypothetical building schemes. Methods of valuation of land with building – rental method, direct comparison of capital cost, valuation based on profit, depreciation method. Free hold and leasehold properties, Forms of rent, Rent fixation- Methods.

**Text Books:**

1. B. N. Dutta, Estimation and Costing in Civil Engineering, UBS publishers
2. Rangwala, Estimation Costing and Valuation, Charotar publishing house pvt. ltd
3. Dr. S. Seetha Raman, M.Chinna Swami, Estimation and Quantity Surveying, Anuradha publications Chennai.
4. M Chakraborty, Estimating, Costing, Specification and valuation, published by the author, 21 B, Babanda Road, Calcutta 26

**References:**

1. B S Patil, Civil Engineering Contracts and Estimates, university press
2. V N Vazirani & S P Chandola, Civil Engineering Estimation and Costing, Khanna Publishers
3. IS 1200-1968; Methods of Measurement of Building & Civil Engineering Works
4. CPWD DAR 2018 and DSR 2018 or latest

**Lecture Plan**

Module	Topic	Course Outcomes addressed	No. of Lectures
<b>1</b>	<b>Module I: Total lecture hours: 7</b>		
1.1	Introduction, estimation, purpose of estimation	CO3	1
1.2	Types of estimates, simple problems of approximate estimate	CO3	2
1.3	Specification, objectives, principles of specification writing, design of ideal specification	CO1	1
1.4	Types of specifications	CO1	1
1.5	Detailed specification of excavation, PCC & RCC, mortars, brick works.	CO2	2
<b>2</b>	<b>Module II: Total lecture hours: 6</b>		
2.1	Analysis of rate, need, factors affecting, Introduction to the use of CPWD DSR and DAR, overhead charges	CO2	1
2.2	Analysis of rates for earth works, PCC, RCC Works, finishes, masonry works, stone works, flooring, with reference to latest DSR and DAR. (Required data for rate analysis will be provided in the question paper.)	CO2	3

2.3	Tender, types, Contract,types,factors affecting, contract document, General and important conditions of contract.Duties and roles of client, architect/engineer, contractor and local bodies	CO2	2
<b>3</b>	<b>Module III: Total lecture hours: 16</b>		
3.1	Different methods of detailed estimation- center line method and long wall short wall method.	CO4	2
3.2	Preparation of detailed measurement and abstract of estimatefor RCC single storey buildings-Excavation for foundation, Foundation and basement, DPC, Masonry in superstructure, RCC, Plastering, Painting, Flooring, Woodwork.	CO4	8
3.3	Estimation of Septic tank and soak pit	CO4	2
3.4	BBS of lintel, beam, slab and column footing	CO4	4
<b>4</b>	<b>Module IV: Total lecture hours:16</b>		
4.1	Valuation-purpose, different forms of values	CO5	1
4.2	Capitalized value, years purchase, sinking fund, Gross income, net income, outgoings –simple problems	CO5	3
4.3	Depreciation – methods of calculating depreciation – straight line method, constant percentage method, sinking fund method, and quantity survey method-problems,obsolescence	CO5	3
4.4	Methods of valuation of open land – comparative method, abstractive method, belting method, valuation based on hypothetical building schemes-Problems based on this	CO5,CO6	3
4.5	Methods of valuation of land with buildings – rental method, direct comparison with capital cost, valuation based on profit, depreciation method-Problems based on this	CO5,CO6	4
4.6	Free hold and leasehold properties, Forms of rent, Rent fixation- Methods. Simple problems based on this	CO6	2

**MODEL QUESTION PAPER**

Reg.No.: \_\_\_\_\_

Name: \_\_\_\_\_

**APJ ABDUL KALAM TECHNOLOGICAL UNIVERSITY****SIXTH SEMESTER B.TECH. DEGREE EXAMINATION****Course Code: CET382****Course Name: ESTIMATION, COSTING AND VALUATION**

Max.Marks:100

Duration: 3Hours

**PART A***Answer all questions; each question carries 3 marks. (10×3 marks = 30 marks)*

1.
  - a) Differentiate revised estimate and supplementary estimate
  - b) What are the principles of specification writing?
  - c) Explain the use of data book and schedule of rates
  - d) What are the important points to be noted while preparing contract document?
  - e) In a simply supported beam of depth 450mm is provided with a 3, 20mm diameter bar at bottom, in this one bar is provided as bendup bar near both the supports. 10mm stirrups are provided with top and bottom cover 25mm. Calculate the additional length provided for bend up in both end. If the (i) bendup angle is  $45^\circ$  and (ii) bendup angle is  $30^\circ$ .
  - f) Write the unit of measurement of (i) DPC using waterproofing compound (ii) Iron work for window (iii) Water proof Painting above roof slab
  - g) Differentiate book value and market value
  - h) Differentiate depreciation and obsolescence
  - i) Explain how will you find out the valuation of land by hypothetical building scheme
  - j) Explain the depreciation method of valuation

**PART B***Answer one full question from each module (Assume any missing data suitably)***Module I**

2.
  - a) Prepare approximate estimate of a public building having plinth area equal to 1800 sq.m.

- i. Plinth area rate as ₹. 35,000 / sq. m.
  - ii. Special architectural treatment = 3% of cost of building.
  - iii. Water supply and sanitary installation = 5% of cost of building.
  - iv. Electric installation = 14% of cost of building.
  - v. Other services = 5% of cost of building.
  - vi. Contingencies = 3% of overall cost of building.
  - vii. Supervision charges = 8% of overall cost of building. (10marks)
- b) Differentiate detailed estimate and preliminary estimate. What are the documents to be accompanied with detailed estimate? (6marks)

OR

3. Differentiate general specification and detailed specification with suitable example (16marks)

### Module II

4. a) What are the factors affecting the rate of a particular item of work. (6 marks)
- b) Develop unit rate analysis for Providing and laying in position cement concrete of specified grade excluding the cost of centering and shuttering - All work up to plinth level 1:1½:3 (1 Cement: 1½ coarse sand (zone-III) : 3 graded stone aggregate 20 mm nominal size)

Details of cost for 1 cum.

MATERIAL: Stone Aggregate (Single size) 20 mm nominal size  $0.57 \text{ m}^3 @ ₹1350/\text{m}^3$ , Stone Aggregate (Single size): 10 mm nominal size  $0.28 \text{ m}^3 @ ₹1350/\text{m}^3$ , Coarse sand (zone III)  $0.425 \text{ m}^3 @ ₹1350/\text{m}^3$ , Portland Cement (0.2833 cum) 0.40 tonne @ ₹4940/tonne

LABOUR: Mason (average) 0.1/day @ ₹709/day, Beldar 1.63/day @ ₹558/day, Bhisti 0.70/day @ ₹617/day

HIRE CHARGES: Concrete Mixer 0.25 to 0.40 cum with hooper 0.07/day @ ₹800/day  
Vibrator (Needle type 40mm) 0.07/day @ ₹370/day

CARRIAGE CHARGES: Stone aggregate below 40 mm nominal size  $0.85 \text{ m}^3 @ ₹103.77/\text{m}^3$ , Coarse sand  $0.425 \text{ m}^3 @ ₹103.77/\text{m}^3$ , Portland cement 0.40 tonne @ ₹92.24/tonne

Sundries: 14.3LS @ ₹2.00/LS (10marks)

OR

5. a. Explain the different types of contracts (8 marks)
- b. What are the general and important conditions of contract? (8 marks)

### Module III

6. Prepare the detailed estimate of the following items of the building. Refer Fig. No. 1

(22 marks)

- i. Excavation for foundation.
- ii. RR masonry in foundation and plinth (1:6)
- iii. Brick Masonry in superstructure (1:6).
- iv. Mosaic tile flooring.

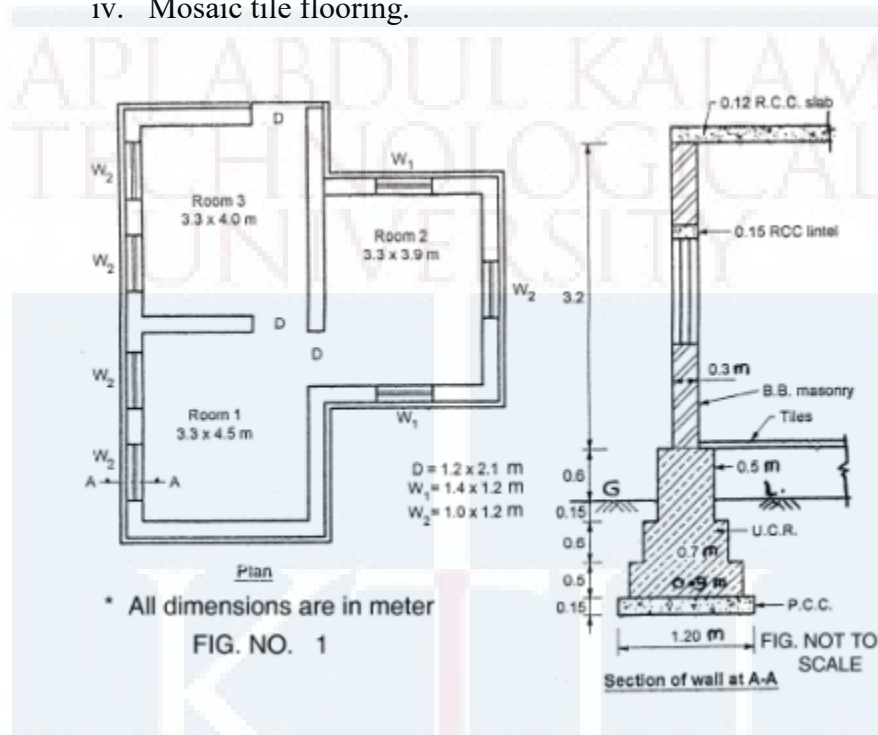

OR

7. Prepare the detailed estimate of following items of septic tank shown below (22 marks)
- a) Earth work in excavation
  - b) Cement concrete 1:2:4
  - c) R.C.C work 1:1 ½:3
  - d) Plastering in C.M 1:3
  - e) Brick masonry

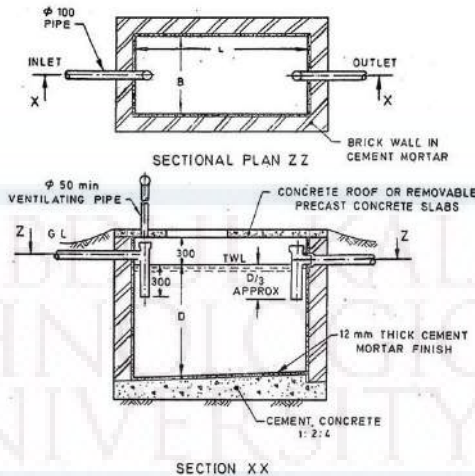

### Module IV

8. a) A concrete mixer was purchased at ₹.8000/-. Assuming salvage value to be ₹.1000, after 5 years, calculate depreciation for each year adopting (a) Straight line method (b) Constant percentage method and (c) Sinking fund method considering 6% interest. (8 marks)
- b) A lease-hold property is to produce a net income of ₹.1,20,000/- per annum for the next 60 years. What is the value of the property? Assume that the land lord desires a return of 6% on his capital and the sinking fund to replace the capital is also to accumulate at 6%. What will be the value of the property if the rate of interest for redemption of capital is 3%? (8 marks)

OR

9. a) A property consists of a south facing plot of land, having south-east and north sides in due directions, which measures 60m, 180m and 80m respectively. It consists of an old two storied building, having a total cubical content of 2840 cubic metres. Assuming prime cost of construction of the building as ₹.20000/- per cubic metre and allowing 10% old materials value only for the building, what would you recommend as the fair value of the property, if the front belt land (depth of front belt being 25m) be estimated at ₹.9000/- per sqm? (8 marks)
- b) The owner of a building gets a net annual rent of ₹.85,500. The future life of building is estimated to be 12 years. But if recommended repairs are carried out immediately at an estimated cost of ₹.3, 00,000, it is expected to last for at least 30 years. Assuming rate of interest as 8%, determine whether it is economical to carry out the recommended repairs to the building or leave it as it is. (8 marks)

CET 384	GEOTECHNICAL INVESTIGATION & GROUND IMPROVEMENT TECHNIQUES	CATEGORY	L	T	P	CREDIT	Year of Introduction
		VAC	4	0	0	4	2019

**Preamble:** Goal of this course is to expose the students to various methods of soil exploration, to recognize weak soils based on the soil investigation reports and to analyze suitable remedial measures to improve the properties of weak soils. After this course, students will be able to recognize practical problems in real-world situations and respond accordingly.

**Prerequisite :** CET283 Introduction to Geotechnical Engineering

**Course Outcomes:** After completion of the course the student will be able to:

CO 1	Understand soil exploration methods
CO 2	Explain different methods of ground improvement techniques with and without addition of other materials
CO 3	List various types, functions and practical applications of Geosynthetics
CO 4	Describe the application of reinforcement function of geosynthetics in retaining structures like Reinforced Earth Retaining Walls, Gabions and Soil nailing
CO 5	Solve the field problems related to geotechnical engineering by applying ground improvement techniques

**Mapping of course outcomes with program outcomes (Minimum requirement)**

	PO 1	PO 2	PO 3	PO 4	PO 5	PO 6	PO 7	PO 8	PO 9	PO 10	PO 11	PO 12
CO 1	3	-	-	-	-	-	-	-	-	-	-	-
CO 2	2	3	-	-	-	-	-	-	-	-	-	-
CO 3	3		-	-	-	-	-	-	-	-	-	-
CO 4	2	3	-	-	-	-	-	-	-	-	-	-
CO5	2	2	3									

**Assessment Pattern**

Bloom's Category	Continuous Assessment Tests		End Semester Examination (Marks)
	Test 1 (Marks)	Test 2 (Marks)	
Remember	20	20	40
Understand	20	20	40
Apply	10	10	20
Analyse			
Evaluate			



Create			CIVIL ENGINEERING
--------	--	--	-------------------

### **Mark Distribution**

Total Marks	CIE Marks	ESE Marks	ESE Duration
150	50	100	3 hours

### **Continuous Internal Evaluation (CIE) Pattern :**

Attendance	: 10 Marks
Continuous Assessment Test (2 numbers)	: 25 Marks
Assignment/Quiz/Course project	: 15 Marks

**End Semester Examination (ESE) Pattern** : There will be two parts; Part A and Part B. Part A contains 10 questions with 2 questions from each module, having 3 marks for each question. Students should answer all questions. Part B contains 2 questions from each module of which student should answer any one. Each question can have maximum 2 sub-divisions and carry 14 marks.

### **Course Level Assessment Questions**

*(Questions may be framed based on the outline given under each course outcome)*

Course Outcome 1 (CO1):

1. Understand Soil Investigation and Soil Exploration methods

Course Outcome 2 (CO2):

1. Explain different methods of ground improvement techniques without addition of any materials viz. surface compaction & deep compaction
2. Explain different methods of ground improvement techniques with addition of other materials viz. grouting and lime stabilization

Course Outcome 3 (CO3):

1. List various types of Geosynthetics
2. List functions of Geosynthetics
3. List practical applications of Geosynthetics

Course Outcome 4 (CO4):

1. Explain reinforced earth retaining walls
2. Explain Gabions
3. Explain Soil Nailing

Course Outcome 5 (CO5):

1. Explain solutions of suitable ground improvement techniques for various practical situations

**Module 1**

**Site investigation and soil exploration:** Introduction and practical importance – objectives Planning of a sub-surface exploration program – Reconnaissance – Preliminary investigation - Detailed investigation - methods of subsurface exploration – direct methods - Open pits and trenches - Semi direct methods – Borings - Auger boring – Shell and Auger Boring - Wash boring, percussion drilling and rotary drilling – advantages and disadvantages -Guidelines for choosing spacing and depth of borings [I.S. guidelines only] - Sampling - disturbed samples, undisturbed samples and chunk samples - Types of samplers – Split spoon sampler – Thin-walled sampler – Piston sampler - Rotary sampler – Core Recovery and Rock Quality Designation

**Module 2**

Sounding and Penetration Tests - Standard Penetration Test – Procedure - Corrections to be applied to observed N values – Numerical examples - Factors influencing the SPT results and precautions to obtain reliable results – Merits and drawbacks of the test - Correlations of N value with various engineering and index properties of soils - Static Cone Penetration Test (SCPT) and Dynamic Cone Penetration Test (DCPT) – Brief Procedure - Merits/drawbacks - Boring log - soil profile- Location of Water table - Geophysical methods : Seismic Refraction method and Electrical Resistivity method – Brief Procedure - Merits/drawbacks

**Module 3**

Ground Improvement Techniques : Introduction – Objectives - Soil improvement without the addition of any material : Shallow and Deep Compaction - Shallow compaction – Rollers - Deep Compaction - Dynamic compaction - Compaction piles - Blasting technique - Vibro compaction– Vibroflotation - Terra probe method - Vibro replacement - sand piles and stone columns - Preloading techniques – sand drains

**Module 4**

Soil improvement by adding materials : Grouting – materials - Grouting systems : One shot and two shot systems - Modes of grouting - Main types of grouting : Permeation Grouting, Compaction Grouting and Jet Grouting – Practical Applications - Grouting Plant and equipment - Grouted columns – Curtain and blanket grouting – Practical applications - Lime stabilization –Mechanism- optimum lime content-lime fixation point

**Module 5**

Soil improvement using Geosynthetics : Materials of Geosynthetics - Types of Geosynthetics - Types of Geotextiles and Geogrids - Functions of Geosynthetics - Practical applications - Introduction to reinforced earth – principles – reinforcing materials - Reinforced earth retaining walls – components – construction sequence – practical applications - Gabions – Introduction - practical applications - Soil Nailing – Introduction – practical applications

**Text Books:**

1. Ranjan G. and A. S. R. Rao, Basic and Applied Soil Mechanics, New Age International, 2002.
2. Purushotham S. Raju, Ground Improvement Technique, Laxmi Publications

**References:**

1. Shashi K. Gulhati and Manoj Dutta, Geotechnical Engineering, Tata McGraw-Hill Publishing Company Limited, New Delhi, 2008
2. Venkatramaiah, Geotechnical Engg, Universities Press, 2000.
3. Arora K. R., Geotechnical Engineering, Standard Publishers, 2006.
4. Moseley, Text Book on Ground Improvement, Blackie Academic Professional, Chapman & Hall, 2004
5. Boweven R., Grouting in Engineering Practice, Applied Science Publishers Ltd
6. Sivakumar Babu, G. L., An introduction to Soil Reinforcement and Geosynthetics, Universities Press (India) Private Limited, 2006
7. Jewell R.A., Soil Reinforcement with Geotextiles, CIRIA Special Publication, Thomas Telford
8. Donald .H. Gray & Robbin B. Sotir, Bio Technical & Soil Engineering Slope Stabilization, John Wiley
9. Rao G.V. & Rao G.V.S., Engineering with Geotextiles, Tata McGraw Hill
10. Korener, Construction & Geotechnical Methods In Foundation Engineering, McGraw Hill

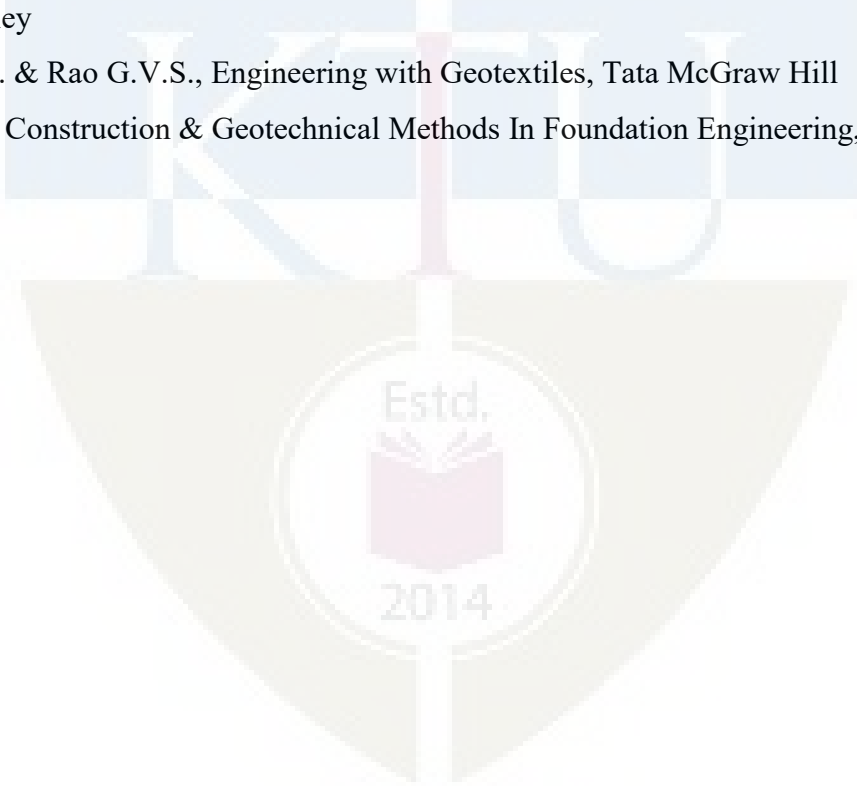

**Course Contents and Lecture Schedule:**

CIVIL ENGINEERING

<b>Module</b>	<b>Contents</b>	<b>Outcomes Addressed</b>	<b>Hours</b>
<b>1</b>	<b>Module 1</b>		<b>9</b>
1.1	<b>Site investigation and soil exploration:</b> Introduction and practical importance - objectives	CO 1	1
1.2	Planning of a sub-surface exploration program – Reconnaissance – Preliminary investigation	CO 1	1
1.3	Detailed investigation - methods of subsurface exploration – direct methods - Open pits and trenches	CO 1	1
1.4	Semi direct methods – Borings - Auger boring – Shell and Auger Boring - Wash boring, percussion drilling and rotary drilling – advantages and disadvantages	CO 1	2
1.5	Guidelines for choosing spacing and depth of borings [I.S. guidelines only]	CO 1	1
1.6	Sampling - disturbed samples, undisturbed samples and chunk samples	CO 1	1
1.7	Types of samplers – Split spoon sampler – Thin-walled sampler – Piston sampler - Rotary sampler – Core Recovery and Rock Quality Designation	CO 1	2
<b>2</b>	<b>Module 2</b>		<b>9</b>
2.1	Sounding and Penetration Tests - Standard Penetration Test – Procedure	CO 1	1
2.2	Corrections to be applied to observed N values – Numerical examples	CO 1	1
2.3	Factors influencing the SPT results and precautions to obtain reliable results – Merits and drawbacks of the test	CO 1	1
2.4	Correlations of N value with various engineering and index properties of soils	CO 1	1
2.5	Static Cone Penetration Test (SCPT) and Dynamic Cone Penetration Test (DCPT) – Brief Procedure - Merits/drawbacks	CO 1	2
2.6	Boring log - soil profile- Location of Water table	CO 1	1
2.7	Geophysical methods : Seismic Refraction method and Electrical Resistivity method – Brief Procedure - Merits/drawbacks	CO 1	2
<b>3</b>	<b>Module 3</b>		<b>9</b>
3.1	Ground Improvement Techniques : Introduction - Objectives	CO 2	1
3.2	Soil improvement without the addition of any material : Shallow and Deep Compaction	CO 2	1

3.3	Shallow compaction - Rollers	CO 2	1
3.4	Deep Compaction - Dynamic compaction	CO 2	1
3.5	Compaction piles	CO 2	1
3.6	Blasting technique	CO 2	1
3.7	Vibro compaction– Vibroflotation - Terra probe method	CO 2	1
3.8	Vibro replacement - sand piles and stone columns - Preloading techniques – sand drains	CO 2	2
<b>4</b>	<b>Module 4</b>		<b>9</b>
4.1	Soil improvement by adding materials : Grouting - materials	CO 2	1
4.2	Grouting systems : One shot and two shot systems - Modes of grouting	CO 2	1
4.3	Main types of grouting : Permeation Grouting, Compaction Grouting and Jet Grouting – Practical Applications	CO 2 & CO 5	3
4.4	Grouting Plant and equipment	CO 2	1
4.5	Grouted columns – Curtain and blanket grouting – Practical applications	CO 2 & CO 5	1
4.6	Lime stabilization –Mechanism-optimum lime content-lime fixation point	CO 2	1
<b>5</b>	<b>Module 5</b>		<b>9</b>
5.1	Soil improvement using Geosynthetics : Materials of Geosynthetics	CO 3	1
5.2	Types of Geosynthetics - Types of Geotextiles and Geogrids	CO 3	1
5.3	Functions of Geosynthetics - Practical applications	CO 3 & CO5	1
5.4	Introduction to reinforced earth – principles – reinforcing materials	CO 4	1
5.5	Reinforced earth retaining walls – components – construction sequence – practical applications	CO 4 & CO5	2
5.6	Gabions – Introduction - practical applications	CO 4 & CO5	1
5.7	Soil Nailing – Introduction – practical applications	CO 4 & CO5	1

QP CODE:

Reg No.: \_\_\_\_\_

Name: \_\_\_\_\_

**APJ ABDUL KALAM TECHNOLOGICAL UNIVERSITY**  
SIXTH SEMESTER B.TECH DEGREE EXAMINATION, MONTH & YEAR

Course Code: CET 384

**Course Name : GEOTECHNICAL INVESTIGATION & GROUND IMPROVEMENT  
TECHNIQUES**

Max. Marks: 100

Duration: 3 hours

**Part A**

*(Answer all questions; each question carries 3 marks)*

1. Explain Objectives of soil exploration
2. List out the factors, which affect the spacing between the bore holes
3. Discuss the merits and demerits of SPT in the sub-surface investigation
4. Discuss any one method of determining the ground water table.
5. Explain Compaction piles in sand
6. Explain Significant depth of influence in Deep compaction.
7. Explain One Shot system and two shot system in grouting
8. Explain optimum lime content and lime fixation point
9. Differentiate between Woven and Non-woven geotextiles.
10. Explain the principle of reinforced earth.

**PART B**

*(Answer one full question from each module, each question carries 14 marks)*

**Module – 1**

11. (a) Give guidelines, which enable the determination of the depth of exploration (5 Marks)  
(b) Explain Wash boring methods of site exploration with neat sketch. What are the advantages and disadvantages of this method. (9 Marks)
12. (a) Distinguish between thin-wall and thick-wall samplers (5 Marks)  
(b) Explain Auger boring and Shell & Auger boring methods of site exploration with neat sketches. What are the advantages of these methods. (9 Marks)

**Module – 2**

13. (a) Explain Static Cone Penetration Test. (5 Marks)  
(b) What is Standard Penetration Test? Explain the test setup and the procedure of conducting the test. What are the corrections to the observed SPT (N) value? (9 Marks)
14. (a) Explain Dynamic Cone Penetration Test. (5 Marks)  
(b) Explain Seismic Refraction Method of exploration. What are its limitations? (9 Marks)

### Module – 3

### CIVIL ENGINEERING

15. (a) Explain the dynamic compaction process for granular soils. (7 Marks)  
(b) Explain Vibroflotation with neat sketch. What are the practical applications? (7 Marks)
16. (a) Explain Sand Piles and Stone Columns. (7 Marks)  
(b) Explain Preloading Techniques with neat sketch. What are the advantages and disadvantages? (7 Marks)

### Module – 4

17. (a) Explain Grouting Plant and Equipment (5 Marks)  
(b) Explain Compaction Grouting. What are its practical applications? (9 Marks)
18. (a) Explain Lime stabilization method. (5 Marks)  
(b) Explain jet grouting method. What are its practical applications? (9 Marks)

### Module – 5

19. (a) What are the functions of geosynthetics? (5 Marks)  
(b) Explain Gabions and Soil Nailing. What are its practical applications? (9 Marks)
20. (a) List different types of geosynthetics. (5 Marks)  
(b) Explain the components of Reinforced Earth Retaining Walls with neat sketch. What are the practical applications of reinforced earth? (9 Marks)

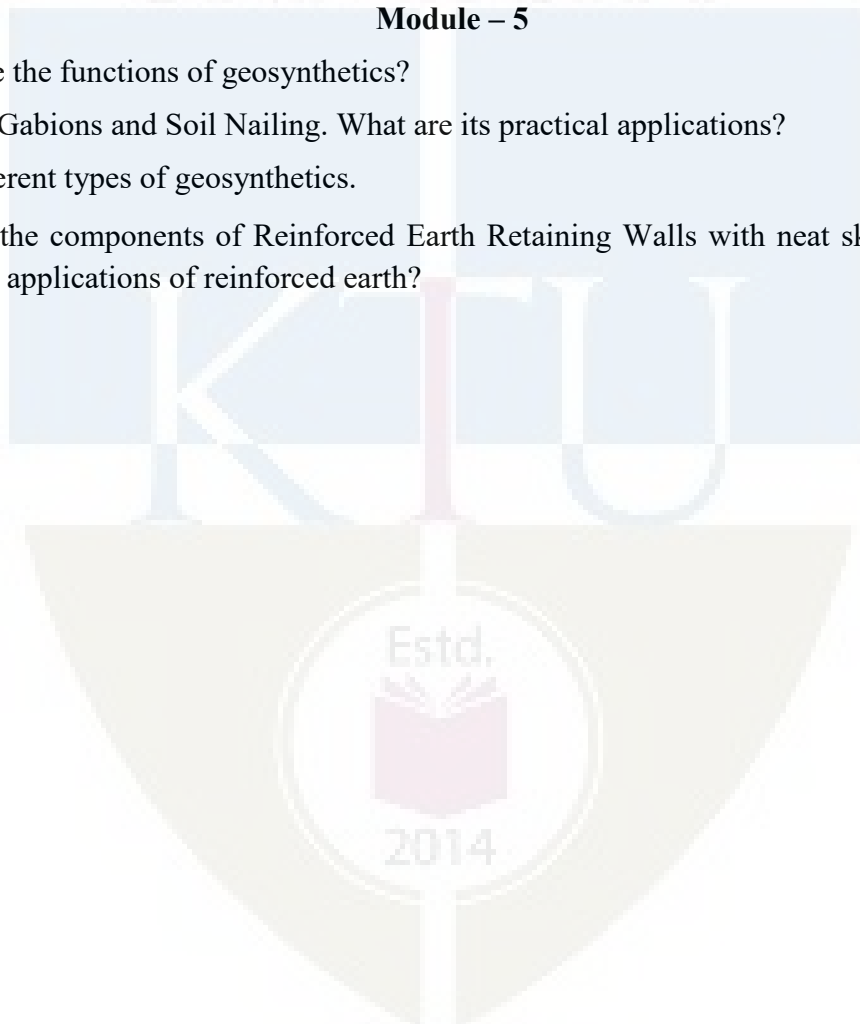

CET 386	ENVIRONMENTAL HEALTH AND SAFETY	CATEGORY	L	T	P	CREDIT	Year of Introduction
		VAC	3	1	0	3	2019

**Preamble:** The course is designed to build environmental health literacy among students and encourages them to take safety measures against various environmental hazards. It motivates the students in maintaining and improving the quality of the environment and empower learners to take appropriate actions to reduce the environment pollution.

**Pre-requisite:** Nil

**Course outcome :** After the course, the student will able to:

CO1	Understand the Toxicology and Occupational Health associated with industries.
CO2	Identify chemical and microbial agents that originate in the environment and can impact human health.
CO3	Describe various measures to ensure safety in Construction industry.
CO4	Explain the effect of air and water pollution on environment.
CO5	Describe the safety measures against various environmental hazards.

CET 386 Environmental Health And Safety		PO1	PO2	PO3	PO4	PO5	PO6	PO7	PO8	PO9	PO10	PO11	PO12	PSO1	PSO2	PSO3
	CO1	3					2	2							1	
	CO2	3					2	1								
	CO3	3					2	2								
	CO4	3					2	2								
	CO5	3					2	2								

### Assessment pattern

Bloom's Category	Continuous Assessment Tests		End Semester Examination (Marks)
	Test 1 (Marks)	Test 2 (Marks)	
Remember	15	15	30
Understand	20	20	40
Apply			
Analyze	15	15	30
Evaluate			
Create			



**Continuous Internal Evaluation Pattern:**

Attendance	:	10marks
Continuous Assessment Test(2numbers)	:	25 marks
Assignment/Quiz/Course project	:	15marks
<b>Total</b>	:	<b>50 marks</b>

**End semester examination pattern** – There will be two parts; Part A and Part B. Part A contain 10 questions with 2 questions from each module, having 3 marks for each question. Students should answer all questions. Part B contains 2 questions from each module of which student should answer anyone. Each question can have maximum 2 sub-divisions and carry 14 marks.

**Course Level Assessment**

<b>Qn. No</b>	<b>Question</b>	<b>Marks</b>	<b>Course outcome (CO) Assessed</b>
<b>Part A</b>			
1	What are the socio- economic reasons in safety?	3	CO1
2	Define industrial hygiene.	3	CO1
3	Define noise. What are the compensation aspects of noise?	3	CO2
4	Explain about the biohazard control program.	3	CO2
5	Discuss the possible electrical injuries in a construction industry.	3	CO3
6	What are the hazards due to radiation?	3	CO3
7	What are the criteria air pollutants?	3	CO4
8	Describe the Depletion of Ozone Layer.	3	CO4
9	What are the benefits of safety inspection?	3	CO5
10	Discuss the role of an individual in conservation of natural resources.	3	CO5

<b>Part B</b> (Answer ANY ONE FULL question from each module)			
<b>Module I</b>			
11	Briefly explain about occupational related diseases found in the industries.	14	CO1
12	Write the short notes on : (i) Silicosis (ii) Asbestosis (iii) Anthracosis (iv) Anthrax.	14	CO1
<b>Module II</b>			
13(a)	Write briefly about the classification of biohazardous agents.	7	CO2
13(b)	What are the precautionary measures for chemical hazards?	7	CO2
14	Write short notes on : (i) Vapour (ii) Fog (iii) Dust (iv) Fumes.	14	CO2
<b>Module III</b>			
15	Explain effects of radiation on human body and the methods of radioactive waste disposal.	14	CO3
16(a)	What are the requirements for safe work platform?	7	CO3
16(b)	Discuss about the scaffolding inspections.	7	CO3
<b>Module IV</b>			
17	Describe the effect of air pollution on environment.	14	CO4
18	Describe the effect of water pollution on environment.	14	CO4
<b>Module V</b>			
19 (a)	What is First aid? Explain CPR.	7	CO5
19 (b)	What are the important points to be considered in carrying out workplace inspection?	7	CO5
20 (a)	Explain the first aid measure to be taken during i) gas poisoning, ii) heart attack, iii) chemical splash and iv) electric shock.	10	CO5
20 (b)	Briefly explain the elementary first aid	4	CO5

**Model Question Paper**

CIVIL ENGINEERING

Reg.No.:.....

QP CODE:.....

Name:.....

**APJ ABDUL KALAM TECHNOLOGICAL UNIVERSITY**

**SIXTH SEMESTER B.TECH DEGREE EXAMINATION, MONTH & YEAR**

**Course Code: CET 386**

**Environment Health and Safety**

**Max. Marks: 100**

**Duration: 3 hours**

**Part A**

**(Answer all questions; each question carries 3 marks)**

1. What are the socio- economic reasons in safety?
2. Define industrial hygiene.
3. Define noise. What are the compensation aspects of noise?
4. Explain about the biohazard control program.
5. Discuss the possible electrical injuries in a construction industry.
6. What are the hazards due to radiation?
7. What are the criteria air pollutants?
8. Describe the Depletion of Ozone Layer.
9. What are the benefits of safety inspection?
10. Discuss the role of an individual in conservation of natural resources.

**Part B**

**(Answer one full question from each module; each question carries 14 marks)**

**Module I**

11. Briefly explain about occupational related diseases found in the industries. (14 Marks)

OR

12. Write the short notes on : (14 Marks)

- (i) Silicosis
- (ii) Asbestosis
- (iii) Anthracosis
- (iv) Anthrax.

**Module II**

13. (a) Write briefly about the classification of biohazardous agents.(7 Marks)  
(b) What are the precautionary measures for chemical hazards? (7 Marks)

OR

14. Write short notes on :(14 Marks)  
(i)Vapour(ii) Fog (iii) Dust (iv) Fumes.

### Module III

15. Explain effects of radiation on human body and the methods of radioactive waste disposal. (14 Marks)

OR

16. (a) What are the requirements for safe work platform? (7 Marks)  
(b) Discuss about the scaffolding inspections.(7 Marks)

### Module IV

17. Describe the effect of air pollution on environment. (14 Marks)

OR

18. Describe the effect of water pollution on environment.(14 Marks)

### Module V

19. (a) What are the important points in carrying out workplace inspection?(7 Marks)  
(b) What is First aid? Explain CPR. (7 Marks)

OR

20. (a) Explain the first aid measure to be taken during gas poisoning,(10 Marks)  
heart attack, chemical splash and electric shock.  
(b) Briefly explain the elementary first aid (4 Marks)

**Course Code: CET 386**  
**Environmental Health And Safety**

**Module I**

**Introduction to Occupational Health And Toxicology :** Safety at work – Socio – Economic reasons. Introduction to health and safety at various industries. occupational related diseases-Musculoskeletal disorders, hearing impairment, carcinogens, silicosis, asbestosis, pneumoconiosis – Toxic materials and substances used in work, exposure limits, toxicological investigation, Industrial Hygiene, Arrangements by organisations to protect the workers.

**Module II**

**Chemical hazards**-dust, fumes, vapour, fog, gases, Methods of Control. **Biological hazards**- Classification of Biohazardous agents– bacterial agents, viral agents, fungal, parasitic agents, infectious diseases, control of biological agents at workplaces. Noise, noise exposure regulation and control.

**Module III**

**Safety in Construction industry** - Scaffolding and Working platform, Welding and Cutting, Excavation Work, Concreting, control measures to reduce the risk. Electrical Hazards, Protection against voltage fluctuations, Effects of shock on human body. Radiation Hazards, Types and effects of radiation on human body, disposal of radioactive waste.

**Module IV**

**Air Pollution** - air pollutants from industries, effect on human health, animals, Plants and Materials - depletion of ozone layer-concept of clean coal combustion technology.  
**Water Pollution** - water pollutants-health hazards - effluent quality standards. Waste Management -waste identification, characterization and classification, recycling and reuse.

**Module V**

**Safe working environment** - The basic purpose and benefits of safety inspection, First-aid appliances, Shelters, rest rooms and lunch rooms, use of personal protective equipment, Role of an individual in conservation of natural resources, Methods for controlling water pollution, role of individual in prevention of pollution.

**Text Books:**

1. Environmental and Health and Safety Management by By Nicholas P. Cheremisinoff and Madelyn L. Graffia, William Andrew Inc. NY, 1995.
2. Effective Environmental, Health, and Safety Management Using the Team Approach by Bill Taylor, Culinary and Hospitality Industry Publications Services 2005.

3. The Facility Managers Guide to Environmental Health And Safety by Brian Gallant, Government Inst Publ., 2007.
4. R.K.Jain and Sunil S.Rao , Industrial Safety , Health and Environment Management Systems, Khanna publishers , New Delhi (2006).
5. Mackenzie L Davis, Introduction to Environmental Engineering, McGrawhill Education (India).

**References:**

1. Slote. L, Handbook of Occupational Safety and Health, JohnWilleyand Sons, NewYork.
2. Heinrich H.W, Industrial Accident Prevention, McGrawHillCompany,NewYork,1980.
3. S.P.Mahajan, "Pollution control in process industries", Tata McGraw Hill Publishing Company, New Delhi, 1993.

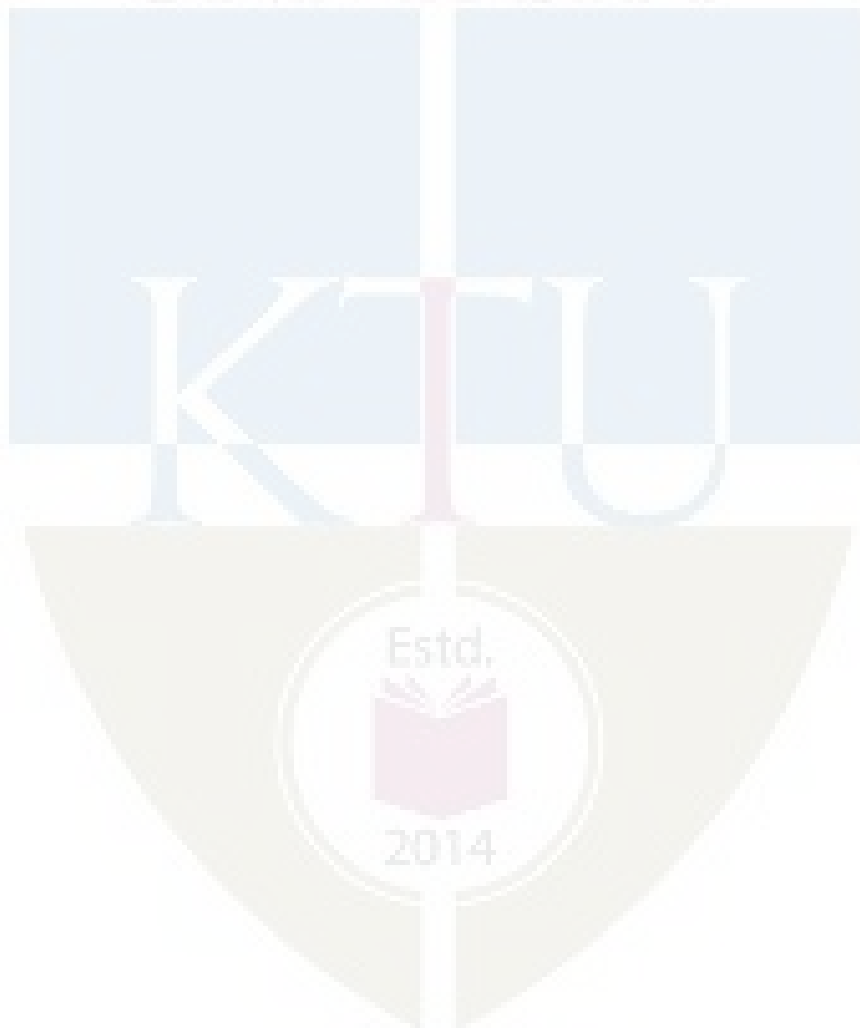

## Environmental Health And Safety

## Course content and Schedule of Lecture (sample)

Module	Topic	Course outcome addressed	No of Hours
<b>Module I (9 Hours)</b>			
1.1	Introduction to Occupational Health And Toxicology.	CO1	1
1.2	Safety at work – Socio – Economic reasons.	CO1	1
1.3	Introduction to health and safety at various industries.	CO1	1
1.4	Occupational related diseases-Musculoskeletal disorders, hearing impairment	CO1	1
1.5	Occupational related diseases - carcinogens, silicosis, asbestosis, pneumoconiosis.	CO1	1
1.6	Toxic materials and substances used in work.	CO1	1
1.7	Exposure limits, toxicological investigation.	CO1	1
1.8	Industrial Hygiene.	CO1	1
1.9	Arrangements by organisations to protect the workers.	CO1	1
<b>Module II (9 Hours)</b>			
2.1	Chemical hazards.	CO2	1
2.2	Dust, fumes, vapour, fog, gases.	CO2	1
2.3	Methods of Control.	CO2	1
2.4	Biological hazards.	CO2	1
2.5	Classification of Biohazardous agents.	CO2	1
2.6	Bacterial agents, viral agents, fungal, parasitic agents, infectious diseases.	CO2	1
2.7	Control of biological agents at workplaces.	CO2	1
2.8	Noise.	CO2	1
2.9	Noise exposure regulation and control.	CO2	1

<b>Module III (8 Hours)</b>			
3.1	Safety in Construction industry- Scaffolding and Working platform.	CO3	1
3.2	Welding and Cutting, Excavation Work, Concreting.	CO3	1
3.3	Control measures to reduce the risk.	CO3	1
3.4	Electrical Hazards.	CO3	1
3.5	Protection against voltage fluctuations.	CO3	1
3.6	Effects of shock on human body, Radiation Hazards	CO3	1
3.7	Types and effects of radiation on human body.	CO3	1
3.8	Disposal of radioactive waste.	CO3	1
<b>Module IV (9 Hours)</b>			
4.1	Air Pollution - air pollutants from industries.	CO4	1
4.2	Effect on human health, animals.	CO4	1
4.3	Plants and Materials - depletion of ozone layer.	CO4	1
4.4	Concept of clean coal combustion technology.	CO4	1
4.5	Water Pollution - water pollutants.	CO4	1
4.6	Health hazards - effluent quality standards.	CO4	1
4.7	Waste Management-waste identification.	CO4	1
4.8	Characterization and classification.	CO4	1
4.9	Recycling and reuse.	CO4	1
<b>Module V (8 Hours)</b>			
5.1	Safe working environment.	CO5	1
5.2	The basic purpose and benefits of safety inspection.	CO5	1
5.3	First-aid appliances.	CO5	1
5.4	Shelters, rest rooms and lunch rooms.	CO5	1
5.5	Use of personal protective equipment.	CO5	1



5.6	Role of an individual in conservation of natural resources.	CO5	1
5.7	Methods for controlling water pollution.	CO5	1
5.8	Role of individual in prevention of pollution.	CO5	1

APJ ABDUL KALAM  
TECHNOLOGICAL  
UNIVERSITY

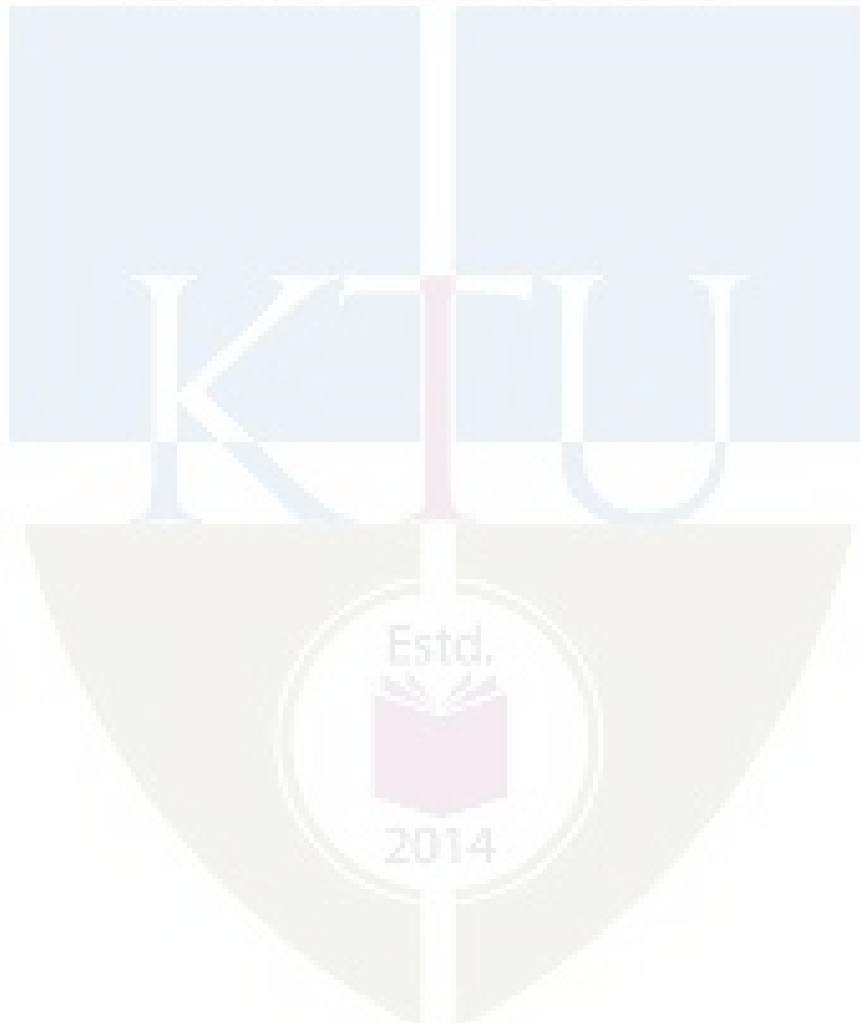

APJ ABDUL KALAM  
TECHNOLOGICAL  
UNIVERSITY

**SEMESTER VI**

**HONOURS**



CET394	FINITE ELEMENT METHODS	CATEGORY	L	T	P	CREDIT	Year of Introduction
		VAC	3	1	0	4	2019

**Preamble:** This course provides the fundamental concepts of finite element method and its applications in structural engineering. As a natural development from matrix analysis of structures learnt earlier, the student is encouraged to appreciate the versatility of this method across various domains, also as the basis of many structural analysis softwares. This course introduces the basic mathematical concepts of the method and its application to simple analysis problems.

**Prerequisite:** CET302 Structural Analysis II

**Course Outcomes:** After the completion of the course the student will be able to

Course Outcome	Description of Course Outcome	Prescribed learning level
CO1	Understand the basic features of boundary value problems and methods to solve them.	Remembering, Understanding
CO2	Understand the fundamental concept of the finite element method and develop the ability to generate the governing FE equations for systems governed by partial differential equations.	Understanding, Applying
CO3	Get familiar with the basic element types and shape functions so as to identify and choose suitable elements to solve a particular problem.	Analysing, Applying
CO4	Understand the concept of isoparametric elements and apply it for problems in structural engineering.	Understanding, Applying
CO5	Apply numerical integration procedures as a tool to solve mathematical models in FEM.	Understanding, Applying

**Mapping of course outcomes with program outcomes (Minimum requirement)**

	PO1	PO2	PO3	PO4	PO5	PO6	PO7	PO8	PO9	PO10	PO11	PO12
CO1	3	2	2	1	-	-	-	-	-	-	-	-
CO2	3	3	2	1	-	-	-	-	-	-	-	-
CO3	3	3	1	1	-	-	-	-	-	-	-	-
CO4	3	3	1	-	-	-	-	-	-	-	-	-
CO5	3	3	1	1	-	-	-	-	-	-	-	-

**Assessment Pattern**

Bloom's Category	Continuous Assessment Tests		End Semester Examination
	1	2	
Remember	05	05	10
Understand	10	10	20
Apply	20	20	40
Analyse	15	15	30
Evaluate			
Create			

### Mark distribution

Total Marks	CIE	ESE	ESE Duration
150	50	100	3 hours

### Continuous Internal Evaluation Pattern:



Attendance	: 10 marks
Continuous Assessment Test (2 numbers)	: 25 marks
Assignment/Quiz/Course project	: 15 marks

**End Semester Examination Pattern:** There will be two parts; Part A and Part B. Part A contain 10 questions with 2 questions from each module, having 3 marks for each question. Students should answer all questions. Part B contains 2 questions from each module of which student should answer any one. Each question carries 14 marks and can have maximum 2 sub-divisions.

**Course Level Assessment Questions**

<b>CO1:</b>	<b>Understand the basic features of boundary value problems and methods to solve them.</b>
1.	What are boundary value problems? What are the physical and mathematical significances of boundary conditions in structural mechanics problems?
2.	Using the Galerkin method obtain an approximate solution to the following boundary value problem. $u''(x) + u(x) + x = 0 \quad 0 < x < 1$ $u(0) = 0 \quad u(1) = 0$ <p>(a) Assume a quadratic polynomial as a trial solution.          (b) Assume a cubic polynomial as a trial solution.</p>
3.	Find a one-parameter approximate solution of the nonlinear equation $-2u \frac{d^2u}{dx^2} + \left( \frac{du}{dx} \right)^2 = 4 \quad \text{for } 0 < x < 1,$ <p>subject to the boundary conditions <math>u(0) = 1</math> and <math>u(1) = 0</math>, and compare it with the exact solution <math>u = 1 - x^2</math>. Use the least-squares method.</p>

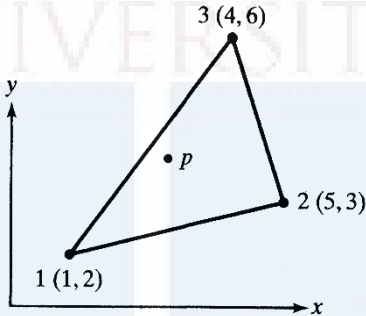
<b>CO2:</b>	<b>Understand the fundamental concept of the finite element method and develop the ability to generate the governing FE equations for systems governed by partial differential equations.</b>
1.	Derive the governing differential equation of a uniform bar subjected to axial vibrations.
2.	What are field variables and forcing vectors in finite element analysis? Give examples from various applications.
3.	Derive the element stiffness equations for an axial deformation problem, using variational approach.
4.	(a) Obtain the weak form of the following boundary value problem. $x^2 \frac{d^2u}{dx^2} + 2x \frac{du}{dx} - xu + 4 = 0 \quad 1 < x < 3$ $u(1) = 1 \quad \frac{du(3)}{dx} - 2u(3) = 2$ <p>(b) With the weak form obtained in (a), use Rayleigh-Ritz method to obtain an approximate solution of the above BVP. Use a linear polynomial trial solution.</p>

<b>CO3:</b>	<b>Get familiar with the basic element types and shape functions so as to identify and choose suitable elements to solve a particular problem.</b>
1.	What are shape functions? What are their advantages in finite element analysis?
2.	Obtain the shape functions for a 4-noded bar element using Lagrange polynomials.
3.	Write the elasticity relations for axisymmetric elements.
4.	For the CST element in figure, x-coordinate at P is 3 and N2 is 0.4 at P. Determine: (a) the y-coordinate at P (b) N1 and N3 at P.
	
5.	Get the explicit shape functions for the rectangular element shown in Figure 3, using Lagrange formulae.
	

<b>CO4:</b>	<b>Understand the concept of isoparametric elements and apply it for problems in structural engineering.</b>
1.	Find the axial deformation of a mild steel square bar of side 3cm and length 2m, using two linear isoparametric axial elements.
2.	Derive the shape functions for an isoparametric Constant Strain Triangle element.
3.	Find the isoparametric mapping for the CST element shown.

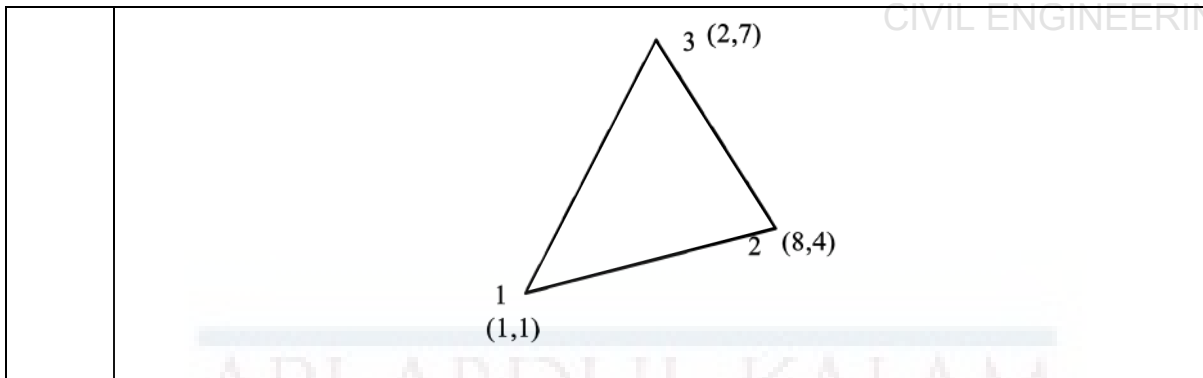

- 4. What are the advantages of coordinate mapping?
- 5. What are superparametric, subparametric and isoparametric elements?
- 6. Illustrate the influence of node numbering on Jacobian, by using a linear triangular isoparametric element.

7. For the axisymmetric triangular elements in Figure, for the loaded edge,

(a) determine the nodal surface traction vector in x-direction.  
 (b) determine the nodal surface traction vector in y-direction

<b>CO5:</b>	<b>Apply numerical integration procedures as a tool to solve mathematical models in FEM.</b>
1.	Evaluate the following integrals using Gauss quadrature: (a) $I = \int_{0.2}^{0.8} e^{-2x} \tan x dx$ (b) $I = \int_{-2}^2 \frac{dx}{1+x^2}$ (c) $I = \int_{-1}^1 \int_{-1}^1 (t^3 + s^2) ds dt$ (d) $I = \int_{-1}^1 \int_{-1}^1 x \sin(x + y^2) dx dy$
2.	What are the essential features of numerical integration using Gauss quadrature?
3.	Obtain the two-point Gauss quadrature points and weights from first principles
4.	How to determine the number of Gauss points to evaluate an integral exactly?

**MODULE I – 9 hrs.**

**Introduction** - Boundary value problems; Introduction to approximate numerical solutions for solving differential equations.

**MODULE II – 9 hrs.**

**Formulation techniques:** Element equations using variational approach- Element equations using weighted residual approach - the axial element example.

**MODULE III – 9 hrs.**

**Basic elements:** Interpolation and shape functions – convergence requirements; CST, LST, bilinear rectangular elements, solid elements.

**MODULE IV – 9 hrs.**

**Isoparametric Formulation:** coordinate mapping - One dimensional bar element; Two dimensional isoparametric elements - CST, LST, bilinear quadrilateral elements - Plain stress, plain strain problems.

**MODULE V – 9 hrs.**

Development of stiffness matrix for *beam elements*; Introduction to *higher order* elements; Introduction to *axisymmetric* elements.

**Numerical Integration:** Gauss quadrature

**Text Books:**

1. Desai, C.S., Elementary Finite Element Method, Prentice Hall of India.
2. Chandrupatla, T.R., and Belegundu, A.D., Introduction to Finite Elements in Engineering, Prentice Hall of India.

**References:**

1. Cook, R.D., et al, Concepts and Applications of Finite Element Analysis, John Wiley.
2. Bathe, K.J., Finite Element Procedures in Engineering Analysis, Prentice Hall of India.
3. Gallagher, R.H., Finite Element Analysis: Fundamentals, Prentice Hall Inc.
4. Rajasekaran, S., Finite Element Analysis in Engineering Design, Wheeler Pub.
5. Krishnamoorthy, C.S., Finite Element Analysis Theory and Programming, Tata McGraw Hill.
6. Zienkiewicz, O.C., and Taylor, R.L., The Finite Element Method, Vol. I and II, McGraw Hill.
7. Bhatti, Asghar, Fundamental Finite Element Analysis and Applications: with Mathematica and Matlab Computations



**Lecture Plan –Structural Analysis II**

Module	Topic	Course Outcomes addressed	No. of Lectures
<b>1</b>	<b>Module I: Total lecture hours: 9</b>		
1.1	General introduction – brief review of matrix methods, applications and versatility of FEM	CO1	1
1.2	Introduction to Boundary value problems; approximate numerical solutions for solving differential equations - Least squares method	CO1	3
1.3	Collocation method, Galerkin method - examples	CO1	5
<b>2</b>	<b>Module II: Total lecture hours: 9</b>		
2.1	<b>Formulation techniques:</b> Variational approach and weighted residual approach – initial concepts and differences	CO2	1
	Element equations using variational approach		3
2.2	Element equations using weighted residual approach	CO2	3
2.3	The axial element example in detail	CO2, CO3	2
<b>3</b>	<b>Module III: Total lecture hours: 9</b>		
3.1	<b>Basic elements:</b> Interpolation and shape functions	CO3	2
3.2	Convergence requirements; CST element	CO3	3
3.3	LST, bilinear rectangular elements, solid elements.	CO3	4
<b>4</b>	<b>Module IV: Total lecture hours: 9</b>		
4.1	<b>Isoparametric Formulation:</b> coordinate mapping - One dimensional bar element	CO4	2
4.2	Two dimensional isoparametric elements – CST element	CO4	3
4.3	LST, bilinear quadrilateral elements - Plain stress, plain strain problems.	CO4	4
<b>5</b>	<b>Module V: Total lecture hours: 9</b>		
5.1	Development of stiffness matrix for beam elements	CO3, CO4	2
5.2	Introduction to higher order elements	CO3, CO4	2
5.3	Introduction to axisymmetric elements.	CO3, CO4	2
5.4	<b>Numerical Integration:</b> Gauss quadrature	CO5	3

Reg.No.: _____		Name: _____	
<b>APJ ABDUL KALAM TECHNOLOGICAL UNIVERSITY</b> <b>SIXTH SEMESTER B.TECH DEGREE EXAMINATION</b>			
<b>Course Code: CET394</b>			
<b>Course Name: FINITE ELEMENT METHODS</b>			
Max. Marks: 100		Duration: 3 Hours	
<b>PART A</b>			
<i>Answer all questions; each question carries 3 marks.</i>			
1.	a)	What are field variables and forcing vectors in finite element analysis? Give examples from various applications.	
	b)	What are boundary value problems? What are the physical and mathematical significances of boundary conditions in structural mechanics problems?	
	c)	List the essential properties of shape functions.	
	d)	Briefly explain the essential features of weighted residual methods to solve partial differential equations.	
	e)	Write down the brief general procedure in finite element analysis.	
	f)	What are shape functions? What are their advantages in finite element analysis?	
	g)	What are the advantages of coordinate mapping?	
	h)	What are superparametric, subparametric and isoparametric elements?	
	i)	What are axisymmetric elements? Explain.	
	j)	How to determine the number of Gauss points to evaluate an integral exactly?	
(10×3 marks = 30 marks)			
<b>PART B</b>			
<i>Answer one full question from each module; each full question carries 14 marks.</i>			
<b>Module I</b>			
2.	Using the Galerkin method obtain an approximate solution to the following boundary value problem. $u''(x) + u(x) + x = 0 \quad 0 < x < 1$ $u(0) = 0 \quad u(1) = 0$ (a) Assume a quadratic polynomial as a trial solution. (b) Assume a cubic polynomial as a trial solution.		
(2×7=14 marks)			
3.	Find a one-parameter approximate solution of the nonlinear equation		

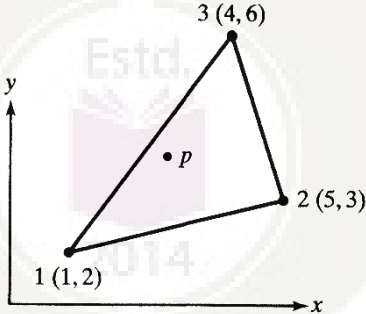
	<p style="text-align: right;">CIVIL ENGINEERING</p> $-2u \frac{d^2u}{dx^2} + \left( \frac{du}{dx} \right)^2 = 4 \quad \text{for } 0 < x < 1,$ <p>subject to the boundary conditions <math>u(0) = 1</math> and <math>u(1) = 0</math>, and compare it with the exact solution <math>u = 1 - x^2</math>. Use the least-squares method.</p> <p style="text-align: right;">(14 marks)</p>
<p><b>Module II</b></p>	
4.	<p>Derive the element stiffness equations for an axial deformation problem, using variational approach.</p> <p style="text-align: right;">(14 marks)</p>
5.	<p>(a) Obtain the weak form of the following boundary value problem.</p> $x^2 \frac{d^2u}{dx^2} + 2x \frac{du}{dx} - xu + 4 = 0 \quad 1 < x < 3$ $u(1) = 1 \quad \frac{du(3)}{dx} - 2u(3) = 2$ <p>(b) With the weak form obtained in (a), use Rayleigh-Ritz method to obtain an approximate solution of the above BVP. Use a linear polynomial trial solution.</p> <p style="text-align: right;">(2×7=14 marks)</p>
<p><b>Module III</b></p>	
6.	<p>For the CST element in figure, x-coordinate at P is 3 and N2 is 0.4 at P. Determine:</p> <p>(a) the y-coordinate at P</p> <p>(b) N1 and N3 at P.</p> <div style="text-align: center;">  </div> <p style="text-align: right;">(2×7=14 marks)</p>
7.	<p>Get the explicit shape functions for the rectangular element shown in Figure 3, using Lagrange formulae.</p>

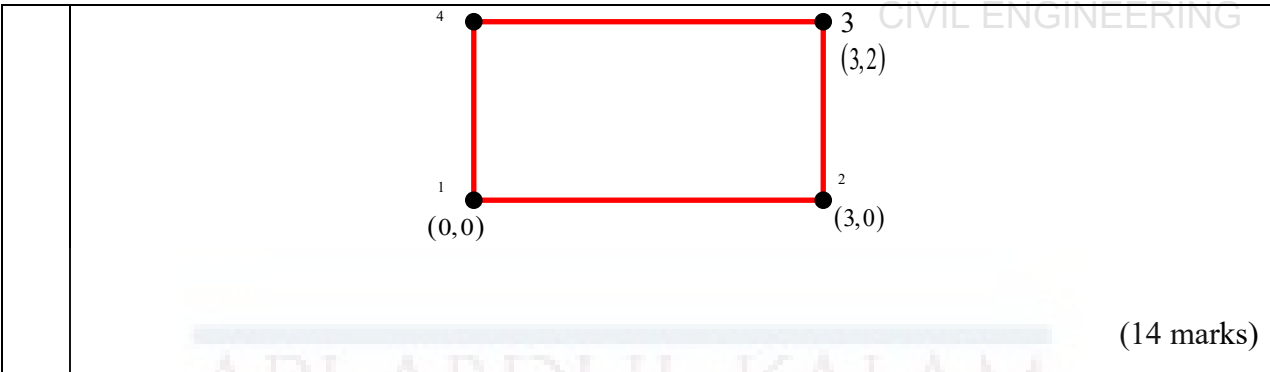

**Module IV**

8. Illustrate the influence of node numbering on Jacobian, by using a linear triangular isoparametric element. (14 marks)

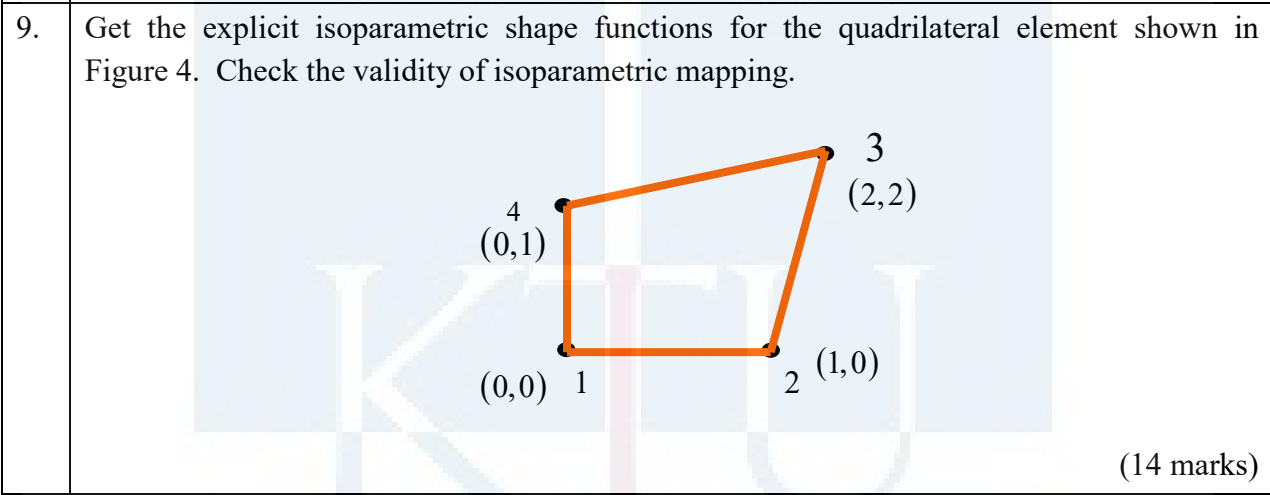

**Module V**

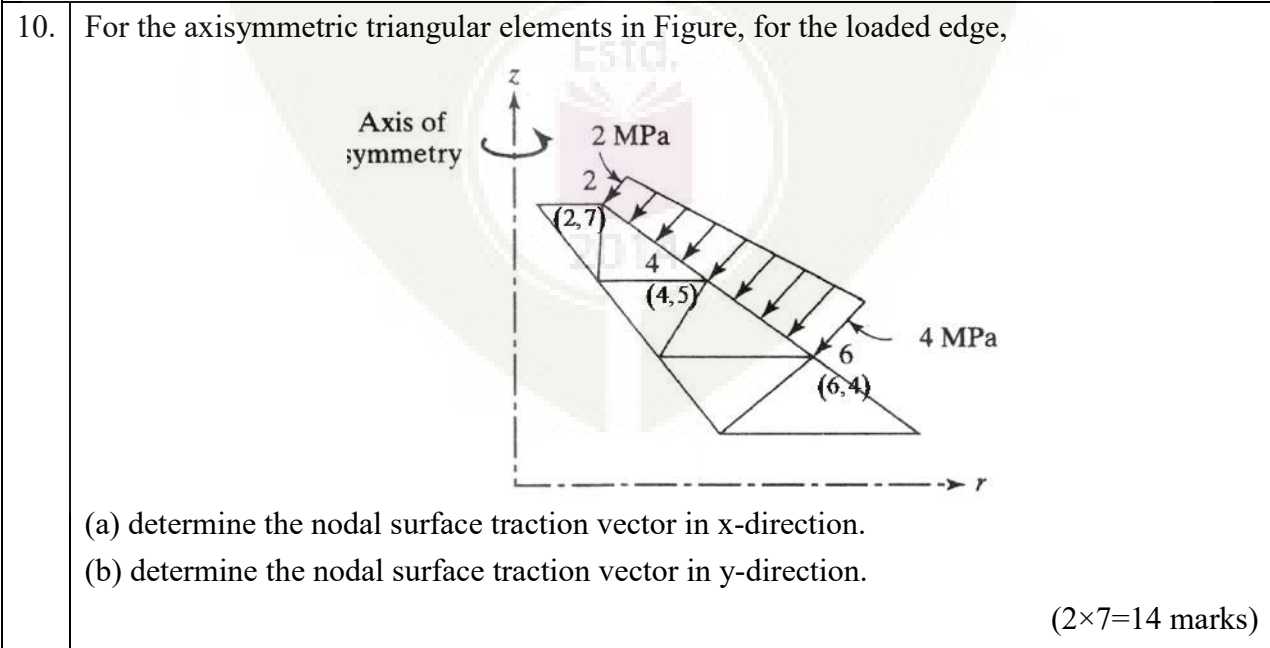

11. Evaluate the following integrals using two-point Gauss quadrature:

$$(a) I = \int_1^2 \int_4^6 xy e^{(x^2+y^2)} dx dy \quad (b) I = \int_{-2}^2 \frac{dx}{1+x^2}$$

(2×7=14 marks)

\*\*\*\*\*

API ABDUL KALAM  
TECHNOLOGICAL  
UNIVERSITY

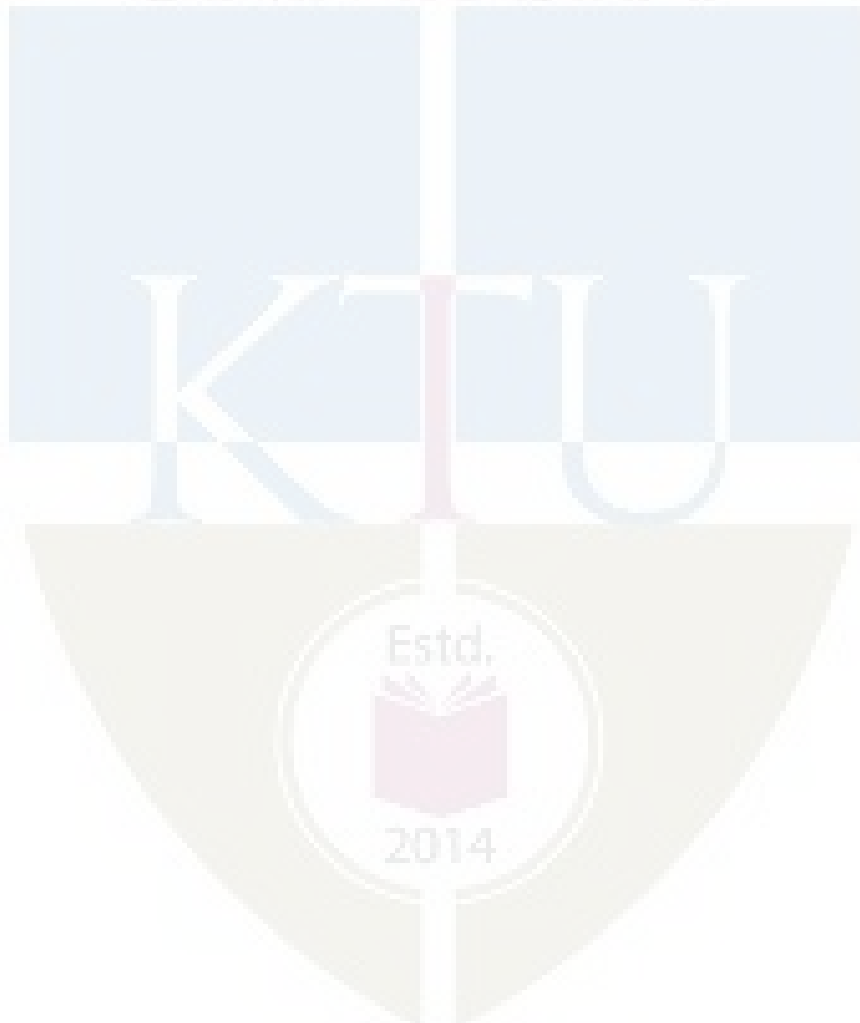

CET 396	EARTH DAMS AND EARTH RETAINING STRUCTURES	CATEGORY	L	T	P	CREDIT	Year of Introduction
		VAC	4	0	0	4	2019

**Preamble:** Goal of this course is to impart to the students, in-depth knowledge about the fundamentals of earth dams and Earth pressure theories. After this course, students will be able to analyze stability of earth dams and various types of retaining structures.

**Prerequisite:** CET 305 : GEOTECHNICAL ENGINEERING II

**Course Outcomes:** After completion of the course the student will be able to:

Course Outcome	Description of Course Outcome
CO 1	Understand the fundamentals of earth dams
CO 2	Analyze slope stability of earth dams
CO 3	Explain the basic concepts & theories of Earth pressure
CO 4	Calculate earth pressure for different types of retaining structures
CO 5	Design Rigid and Flexible Retaining Walls applying the earth pressure theories

**Mapping of course outcomes with program outcomes (Minimum requirement)**

	PO 1	PO 2	PO 3	PO 4	PO 5	PO 6	PO 7	PO 8	PO 9	PO 10	PO 11	PO 12
CO 1	3	-	-	-	-	-	-	-	-	-	-	-
CO2	2	2	3	-	-	-	-	-	-	-	-	-
CO 3	3	-	-	-	-	-	-	-	-	-	-	-
CO 4	2	3	-	-	-	-	-	-	-	-	-	-
CO 5	2	2	3	-	-	-	-	-	-	-	-	-

**Assessment Pattern**

Bloom's Category	Continuous Assessment Tests		End Semester Examination (Marks)
	Test 1 (Marks)	Test 2 (Marks)	
Remember	10	10	20
Understand	15	15	30
Apply	25	25	50
Analyse			
Evaluate			
Create			

## Mark Distribution

CIVIL ENGINEERING

Total Marks	CIE Marks	ESE Marks	ESE Duration
150	50	100	3 hours

### Continuous Internal Evaluation (CIE) Pattern :

Attendance	: 10 Marks
Continuous Assessment Test (2 numbers)	: 25 Marks
Assignment/Quiz/Course project	: 15 Marks

**End Semester Examination (ESE) Pattern** : There will be two parts; Part A and Part B. Part A contains 10 questions with 2 questions from each module, having 3 marks for each question. Students should answer all questions. Part B contains 2 questions from each module of which student should answer any one. Each question can have maximum 2 sub-divisions and carry 14 marks.

### Course Level Assessment Questions

*(Questions may be framed based on the outline given under each course outcome)*

Course Outcome 1 (CO1):

1. Understand the fundamentals of earth dams
2. Understand the types of earth dams
3. Understand the parts of earth dams like central and inclined cores, filters
4. Understand the seepage analysis of earth dams

Course Outcome 2 (CO2):

1. Analyze slope stability of earth dams

Course Outcome 3 (CO3):

1. Explain the basic concepts of Earth pressure
2. Explain Rankine's and Coulomb's theories of Earth pressure
3. Explain Graphical method using Rebhan's method

Course Outcome 4 (CO4):

1. Calculate earth pressure for different types of retaining structures using Rankine's and Coulomb's theories, Graphical Method, Trial wedge method
2. Calculate earth pressure for rigid and flexible retaining walls
3. Calculate earth pressure on Braced cuts and coffer dams

Course Outcome 5 (CO5):

1. Design of gravity retaining wall & cantilever retaining walls applying the earth pressure theories
2. Design of cantilever sheet piles
3. Design of anchored sheet piles
4. Design of Cofferdams

**SYLLABUS**

<b>Module 1</b>
Earth dams – types of dams - Selection of type of dam based on material availability - Foundation conditions and topography - Design details – crest, free board, upstream and downstream slopes, upstream and downstream slope protection – central and inclined cores - Types and design of filters - Seepage analysis and control – seepage through dam and foundations – control of seepage in earth dam and foundation
<b>Module 2</b>
Construction techniques of earth dams – methods of construction - Quality control Instrumentation – measurement of pore pressures - Determination of phreatic line - Stability analysis – critical stability conditions - Desired values of factor of safety for different loading conditions of dam - Evaluation of stability by Swedish Slip Circle Method and sliding wedge method under critical conditions
<b>Module 3</b>
Earth pressure theories – Rankine’s and Coulomb’s earth pressure theories for cohesionless and cohesive backfills – Computation of earth pressures for various cases – inclined – with surcharge – submerged and partly submerged – stratified backfills - Rigid retaining structures – active and passive earth pressures against gravity retaining walls – Numerical Problems - Computation of earth pressures by Trial wedge method – A mathematical approach for completely submerged and partly submerged backfills - Numerical Problems - Importance of capillarity tension in earth pressure
<b>Module 4</b>
Graphical methods of earth pressure computation – trial wedge method for coulomb’s and Rankine’s conditions, for regular and irregular ground and wall conditions - Rebhan’s construction for active pressure - Friction circle method - Logarithmic spiral method - Design of gravity retaining wall – cantilever retaining walls - Numerical Problems - Flexible retaining structure – type and methods of construction – design strength parameters
<b>Module 5</b>
Safety factor for sheet pile walls – Computation of earth pressures against cantilever sheet piles in cohesionless and cohesive soils – Numerical Problems - Anchored sheet piles – free earth method – fixed earth method – Rowe’s moment reduction method - Stability of sheet piling - Diaphragm walls and coffer dams – types of diaphragm walls and their construction techniques in various soil types - Earth pressure on braced cuts and coffer dams – Design of coffer dams

**Text Books :**

1. Tschebotarioff G P, Foundations, Retaining and earth structures, 2nd edition, Mcgraw Hill Pub., 1973



**References:**

1. Clayton, Milititsky and Woods, Earth Pressure And Earth-Retaining Structures, Taylor and Francis, 1996
2. Huntington, Earth pressure on retaining walls, John Wiley and Sons, 1957
3. Prakash, Ranjan and Saran, Analysis and Design of Foundations and Retaining structures, SarithaPrakashan, Meerut, 1977
4. Bowles, Foundation Analysis and Design, 1968.
5. Jones, Earth Reinforcements and Soil structures, 1996
7. IS : 7894 – 1975, Indian Standard Code of Practice for Stability Analysis of Earth Dams

**Course Contents and Lecture Schedule:**

Module	Contents		Hours
<b>1</b>	<b>Module 1</b>		<b>9</b>
1.1	Earth dams – types of dams	CO 1	1
1.2	Selection of type of dam based on material availability	CO 1	1
1.3	Foundation conditions and topography	CO 1	1
1.4	Design details – crest, free board, upstream and downstream slopes, upstream and downstream slope protection – central and inclined cores	CO 1	2
1.5	Types and design of filters	CO 1	2
1.6	Seepage analysis and control – seepage through dam and foundations – control of seepage in earth dam and foundation	CO 1	2
<b>2</b>	<b>Module 2</b>		<b>9</b>
2.1	Construction techniques of earth dams – methods of construction	CO 1	1
2.2	Quality control Instrumentation – measurement of pore pressures	CO 1	1
2.3	Determination of phreatic line	CO 1	1
2.4	Stability analysis – critical stability conditions	CO 1, CO 2	2
2.5	Desired values of factor of safety for different loading conditions of dam	CO 1, CO 2	1
2.6	Evaluation of stability by Swedish Slip Circle Method and sliding wedge method under critical conditions	CO 1, CO 2	3
<b>3</b>	<b>Module 3</b>		<b>9</b>
3.1	Earth pressure theories – Rankine's and Coulomb's earth pressure theories for cohesionless and cohesive backfills – Computation of earth pressures for various cases – inclined – with surcharge – submerged and partly submerged – stratified backfills	CO 3	2
3.2	Rigid retaining structures – active and passive earth pressures against gravity retaining walls – Numerical Problems	CO 3, CO 4	2

3.3	Computation of earth pressures by Trial wedge method – A mathematical approach for completely submerged and partly submerged backfills	CO 3	2
3.4	Numerical Problems	CO 3, CO 4	2
3.5	Importance of capillarity tension in earth pressure	CO 3	1

<b>4</b>	<b>Module 4</b>		<b>9</b>
4.1	Graphical methods of earth pressure computation – trial wedge method for coulomb's and Rankine's conditions, for regular and irregular ground and wall conditions -Rebhan's construction for active pressure	CO 3, CO 4	2
4.2	Friction circle method - Logarithmic spiral method	CO 3	2
4.3	Design of gravity retaining wall – cantilever retaining walls - Numerical Problems	CO 5	3
4.4	Flexible retaining structure – type and methods of construction – design strength parameters	CO 3	2
<b>5</b>	<b>Module 5</b>		<b>9</b>
5.1	Safety factor for sheet pile walls – Computation of earth pressures against cantilever sheet piles in cohesionless and cohesive soils – Numerical Problems	CO3, CO 4	2
5.2	Anchored sheet piles – free earth method – fixed earth method – Rowe's moment reduction method	CO 3, CO 4	2
5.3	Stability of sheet piling	CO 3, CO 5	1
5.4	Diaphragm walls and coffer dams – type of diaphragm walls and their construction techniques in various soil types	CO 3	2
5.5	Earth pressure on braced cuts and coffer dams – Design of coffer dams	CO 3, CO 5	2

**Reg No.:** \_\_\_\_\_

**Name:** \_\_\_\_\_

**APJ ABDUL KALAM TECHNOLOGICAL UNIVERSITY**  
FOURTH SEMESTER B.TECH DEGREE EXAMINATION, MONTH & YEAR

**Course Code: CET396**

**Course Name : EARTH DAMS AND EARTH RETAINING STRUCTURES**

Max. Marks: 100

Duration: 3 hours

**Part A**

*(Answer all questions; each question carries 3 marks)*

1. Explain types of dams
2. Explain downstream slope protection measures
3. Explain the instrumentation for quality control of dams
4. Explain critical stability conditions of dams
5. Explain critical depth for an unsupported cut in cohesive soil.
6. List the assumptions of Coulomb's theory of earth pressure
7. Differentiate between rigid and flexible retaining structures
8. Explain the methods of construction of flexible retaining structures
9. How to check the stability of sheet piling?
10. List the types of Diaphragm walls

**PART B**

*(Answer one full question from each module, each question carries 14 marks)*

**Module – 1**

11. (a) Explain the basic design studies necessary for design of an earth dam. (7 Marks)  
(b) Explain about the seepage through Dam and foundation. (7 Marks)
12. (a) Discuss in detail the Terzaghi's filter criteria for its design. (7 Marks)  
(b) Explain the control of seepage in earth dam. (7 Marks)

**Module – 2**

13. (a) Explain construction techniques of an earth dam. (7 Marks)  
(b) Explain Swedish Slip Circle method of stability analysis. (7 Marks)
14. (a) Explain methods of construction of an earth dam. (7 Marks)  
(b) Explain Sliding Wedge method of stability analysis. (7 Marks)

### Module – 3

15. (a) Explain Trial wedge method of earth pressure. (5 Marks)
- (b) Compute the total lateral earth thrust exerted by a layered backfill of height 10m if the wall has a tendency to move away from the backfill. The upper layer of thickness 4 m has angle of internal friction  $32^\circ$  and unit weight  $19 \text{ kN/m}^3$ . The lower layer has angle of internal friction  $28^\circ$ , cohesion  $20 \text{ kPa}$ , and unit weight  $18 \text{ kN/m}^3$ . The backfill also supports a uniform surcharge of intensity  $10 \text{ kN/m}^2$ . Also find the point of application. (9 Marks)
16. (a) Explain the importance of capillary tension in computation of earth pressure (5 Marks)
- (b) For a layered backfill behind a 10m high retaining wall with a smooth vertical backfill, Draw the active earth pressure distribution and its magnitude and point of application : (9 Marks)

Sl. No.	Depth	Backfill Properties
1.	0 – 3 m	$c = 30 \text{ kN/m}^2, \phi = 0^\circ, \gamma = 19 \text{ kN/m}^3$
2.	3 – 6 m	$c = 0 \text{ kN/m}^2, \phi = 32^\circ, \gamma = 18 \text{ kN/m}^3$
3.	6 – 10 m	$c = 50 \text{ kN/m}^2, \phi = 0^\circ, \gamma = 17 \text{ kN/m}^3$

### Module – 4

17. (a) Explain design strength parameters of a flexible retaining wall. (5 Marks)
- (b) The retaining wall having 6m height having back of wall is inclined at +ve batter angle of  $15^\circ$  and ground surface has an upward inclination of  $20^\circ$  retains a backfill with following properties :  $\gamma = 19 \text{ kN/m}^3, \phi = 34^\circ, \delta = 20^\circ$ .
- (i) Determine the total active thrust by Rebann's graphical construction.
- (ii) A surcharge of  $50 \text{ kN/m}^2$  is acting on the backfill. What is the magnitude of total active thrust? (9 Marks)
18. (a) Explain Logarithmic Spiral method. (5 Marks)
- (b) A trapezoidal masonry retaining wall 1.5m wide at the top and 5m wide at its bottom is 5m high. The vertical face is retaining soil ( $\phi = 30^\circ$ ) at a surcharge angle of  $15^\circ$  with the horizontal. Unit weights of soil and masonry are  $20 \text{ kN/m}^3$  and  $24 \text{ kN/m}^3$ . The coefficient of friction at the base of the wall is 0.40. Check the stability of the retaining by applying necessary checks if the soil bearing capacity is  $90 \text{ kN/m}^2$ . (9 Marks)

### Module – 5

19. (a) Explain the step by step procedure for design of a diaphragm wall. (7 Marks)
- (b) Describe the stability checking of sheet pile wall using fixed and free earth support methods. (7 Marks)
20. (a) What are different types of coffer dams? (5 Marks)
- (b) An anchored sheet pile is to support a mass of cohesion less soil up to height of 6m above ground level with horizontal anchor toes spaced at 1m intervals and located at 1.0m below the ground surface. If the unit weight of the soil is  $21\text{kN/m}^3$  and its angle of internal friction is  $30^\circ$ , determine the minimum depth of embedment of the sheet pile for stability. (9 Marks)

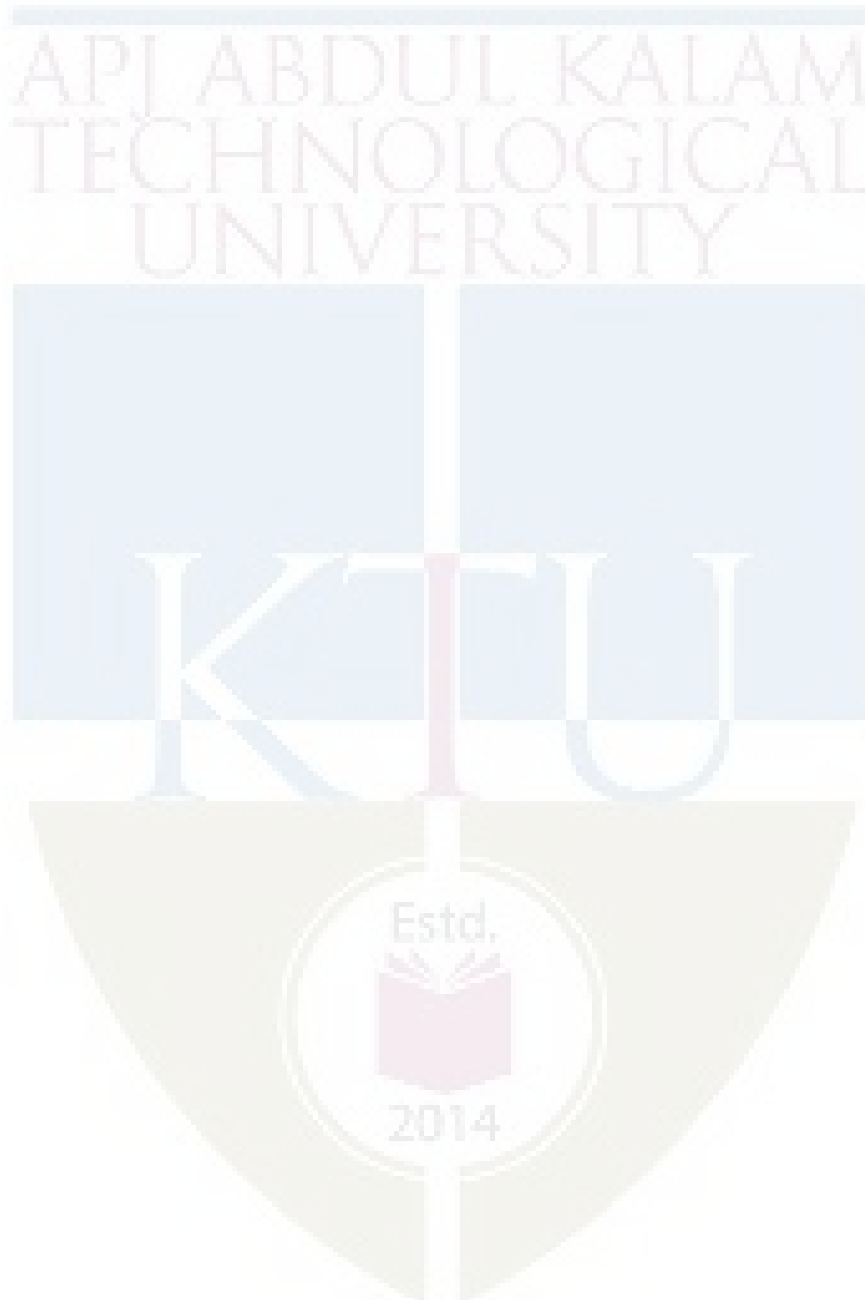

CET 398	ENVIRONMENTAL POLLUTION MODELLING	CATEGORY	L	T	P	CREDIT	Year of Introduction
		VAC	3	1	0	4	2019

**Preamble :** This course introduces various approaches for environmental pollution modeling. Students will learn how to develop a verified and validated model. The mathematics behind various environmental pollution models with their uncertainties will be discussed.

**Prerequisite:** NIL

**Course Outcomes:** After the completion of the course the student will be able

Course Outcome	Description of Course Outcome	Prescribed learning level
CO1	To appreciate the mathematical modelling approach	Understanding
CO2	To learn how to build a model to represent physical transport of pollutants in environment	Understanding, Applying
CO 3	To simulate pollution transport scenarios in water, air and noise environment	Applying , Analysing
CO 4	To interpret the modelling results for decision support	Analysing

**Mapping of course outcomes with program outcomes (Minimum requirement)**

	PO 1	PO 2	PO 3	PO 4	PO 5	PO 6	PO 7	PO 8	PO 9	PO 10	PO 11	PO 12
CO 1	3	-	-	-	-	-	-	-	-	-	-	-
CO 2	3	-	-	-	-	-	-	-	-	-	-	-
CO 3	-	2	-	2	-	-	-	-	-	-	-	-
CO4	-	2	-	2	-	-	-	-	-	-	-	-

**Assessment Pattern**

Bloom's Category	Continuous Assessment Tests		End Semester Examination
	1	2	
Remember	10	10	15
Understand	10	10	15
Apply	15	15	35
Analyse	15	15	35
Evaluate			
Create			

**Mark distribution**

Total Marks	CIE	ESE	ESE Duration
150	50	100	3 hours

**Continuous Internal Evaluation Pattern:**

Attendance : 10 marks  
 Continuous Assessment Test (2 numbers) : 25 marks  
 Assignment/Quiz/Course project : 15 marks

**End Semester Examination Pattern:** There will be two parts; Part A and Part B. Part A contain 10 questions with 2 questions from each module, having 3 marks for each question. Students should answer all questions. Part B contains 2 questions from each module of which student should answer any one. Each question carries 14 marks and can have maximum 2 sub-divisions.

**Course Level Assessment Questions****CO1:To appreciate the mathematical modelling approach**

1	Discuss the classification of mathematical models
2	Explain how advection-diffusion equation is useful for modelling contaminant transport in ground water
3	How gaussian dispersion model is useful for air pollution modelling of point sources?

**CO 2: To learn how to build a model to represent physical transport of pollutants in environment**

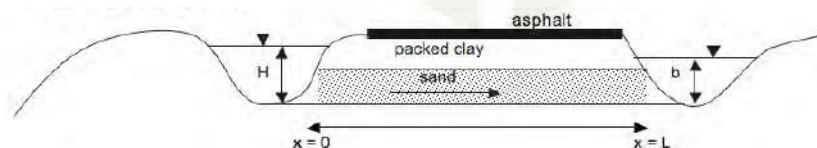
1	Explain model building procedure
2	<p>What is the flow equation for the following situation?</p> 

3	Discuss how salinity intrusion is modeled
---	-------------------------------------------

**CO3: To simulate pollution transport scenarios in water, air and noise environment**

1	The SO <sub>2</sub> concentration from 700 MW coal fired power plant has to be estimated. It burns 5% sulphur coal at the rate of 350KG / MW H. Stack height is 150m and plume rise is 50m. The wind speed at stack height is 6 m/s and neutral stability condition exists. Calculate the ground level concentration at 2 km downwind distance, given that $\sigma_y = 80\text{m}$ and $\sigma_z = 120\text{m}$ .
2	The initial BOD of a river just below a sewage outfall is 25 mg/L. The oxygen deficit just upstream from the outfall is 2 mg/L. The deoxygenation rate coefficient $k_d$ is 0.4/day, and the reaeration rate coefficient $k_r$ is 0.7/day. The river is flowing at a speed of 30 km /day. (a) Find the critical distance downstream at which DO is a minimum (b) Find the minimum DO
3	Water levels in two wells far from shoreline are 50 cm and 1.0 m respectively. The wells are separated by a distance of 1 km. Hydraulic conductivity of the aquifer is 10m/d. Thickness of aquifer is 50m. Calculate the length of saltwater wedge and position of interface. Density of salt water can be taken as 1.025 g/cm <sup>3</sup>

**CO4: To interpret the modelling results for decision support**

1	Explain how gaussian dispersion model help in predicting the impact of a proposed coal power plant in a locality
2	A chemical spill occurs above a sloping, shallow unconfined aquifer consisting of medium sand with $K=1$ m/d and a porosity of 30%. Several monitoring wells are drilled in order to determine the regional hydraulic gradient. The hydraulic head from a well drilled near the spill location yielded a value of 5m. At a distance of 200m down the slope another well yielded a hydraulic head of 1m. Do you need to worry about safe drinking water availability in the well 200 m down the slope?
3	The distance from the base of a pumping well to the freshwater-saltwater interface is 100 m, the pumping rate is 3000 m <sup>3</sup> /day, and the hydraulic conductivity is 10 m/d. What's the maximum permitted pumping rate for the well?



**SYLLABUS****Module1**

Role of models in environmental pollution studies- objectives of modelling-modelling principles-types of models-classification of mathematical models-deterministic, stochastic, continuous, discrete, static, dynamic, linear and non-linear-model building framework-model calibration, validation, verification and sensitivity analysis-model scales, error and uncertainty -distributions in modelling data of environmental pollutant concentrations- log-normal, Weibull, and gamma

**Module 2**

Air pollution modelling: Transport and dispersion of air pollutants- estimating concentrations from point sources –Dispersion Modelling- Gaussian Plume Model – determination of dispersion parameters, atmospheric stability-box models- line source model-area source model-puff model

**Module 3**

Water quality modeling: historical development of water quality models; rivers and streams water quality modelling– low flow analysis – pollutant transport-advection, diffusion and dispersion— Modelling lake water quality-mass balance for well mixed lakes-models for dissolved oxygen; Streeter Phelps model- sediment transport modelling

**Module4**

Groundwater modelling: use of ground water models-ground water flow modeling-Darcy's law-ground water flow equations for homogenous, heterogenous, isotropic and anisotropic conditions-mass transport of solutes,advection diffusion equation,favorable conditions for contaminant transport-modelling parameters and boundary conditions, seawater intrusion – basic concepts and modeling-Ghyben–Herzberg formula-popular ground water models

**Module5**

Environmental noise - noise generation mechanisms- need for noise modelling- modelling inputs-sound propagation factors- Equivalent Continuous Sound Pressure Level (Leq)-noise mapping methodology-modelling traffic noise-CoRTN and RLS90 models

**Text Books**

1. Gilbert M Masters Wendell P Ela, Introduction to Environmental Engineering & Science, Pearson,2013
2. Steven C.Chapra, Surface Water Quality Modeling, The McGraw-Hill Companies,Inc., New York, 1997.
3. Todd David Keith, Ground water Hydrology, Fourth edition, John Wiley and Sons, New York, 2004..
4. C.P Kumar, Ground water assessment and modelling, Createspace Independent Pub, 2015

## References

1. Seinfeld and Pandis, Atmospheric chemistry and physics, Wiley 2016
2. Marcello Benedini, George Tsakiris, Water quality modelling for rivers and streams, Springer 2013
3. Mary Anderson William Woessner Randall Hunt, Applied ground water modelling, Academic Press, 2015
4. Enda Murphy Eoin King, Environmental Noise Pollution, Elsevier, 2014

## Lecture Plan- Environmental Impact Assessment

Module	Topic	Course Outcomes addressed	No. of Lectures
<b>1</b>	<b>Module 1: Total Lecture Hours -9</b>		
1.1	Role of models in environmental pollution studies- objectives of modelling-modelling principles-	CO1	1
1.2	types of models-classification of mathematical models-deterministic, stochastic, continuous, discrete, static, dynamic, linear and non-linear-	CO1	2
1.3	model building framework-model calibration, validation, verification and sensitivity analysis-model scales, error and uncertainty -	CO2	3
1.4	distributions in modelling data of environmental pollutant concentrations- log-normal, Weibull, and gamma	CO1,CO2	3
<b>2</b>	<b>Module II: Total Lecture Hours- 9</b>		
2.1	Air pollution modelling: Transport and dispersion of air pollutants	CO2	1
2.2	estimating concentrations from point sources – dispersion modelling- Gaussian Plume Model – determination of dispersion parameters, atmospheric stability	CO2, CO3, CO4	4
2.3	box models- line source model-area source model-puff model	CO2, CO3, CO4	4
<b>3</b>	<b>Module III: Total Lecture Hours-9</b>		
3.1	Water quality modeling: historical development of water quality models	CO1,CO2	1

3.2	Rivers and streams water quality modelling– low flow analysis – pollutant transport-advection, diffusion and dispersion	CO2, CO3	2
3.3	Modelling lake water quality-mass balance for well mixed lakes	CO2, CO3	2
3.4	models for dissolved oxygen; Streeter Phelps model-	CO2, CO3,CO4	3
3.5	sediment transport modelling	CO2, CO3,CO4	1
<b>4</b>	<b>Module IV: Total Lecture Hours- 9</b>		
4.1	Groundwater modelling: use of ground water models-ground water flow modeling-Darcy's law-ground water flow equations for homogenous, heterogenous, isotropic and anisotropic conditions-	CO1,CO2	3
4.2	mass transport of solutes, advection dispersion equation, favorable conditions for contaminant transport-modelling parameters and boundary conditions	CO2,CO3,CO4	3
4.3	seawater intrusion – basic concepts and modeling-Ghyben–Herzberg formula, popular ground water models	CO2,CO3,CO4	3
<b>5</b>	<b>Module V: Total Lecture Hours- 9</b>		
5.1	Environmental noise - noise generation mechanisms-need for noise modellingnoise mapping methodology-	CO2	3
5.2	modelling inputs-sound propagation factors - Equivalent Continuous Sound Pressure Level (Leq)-	CO2	3
5.3	modelling traffic noise-CoRTN and RLS90 models	CO3	3

**Model Question Paper**

Reg No.: \_\_\_\_\_

Name: \_\_\_\_\_

**APJ ABDUL KALAM TECHNOLOGICAL UNIVERSITY  
SIXTH SEMESTER B.TECH DEGREE EXAMINATION****Course Code: CET398****Course Name: ENVIRONMENTAL POLLUTION MODELLING**

Max. Marks: 100

Duration: 3 Hours

**Part A***(Answer all questions; each question carries 3 marks)*

1. Why do we need models in environmental studies?
2. A model can never represent the reality. Explain
3. What are the assumptions used in a box model?
4. Explain how atmospheric stability influence dispersion of air pollutants?
5. Explain Streeter-Phelps model
6. How modeling lake water quality is different from modeling river water quality?
7. Explain the role of Darcy's law in ground water modelling
8. Explain Ghyben-Herzberg relation
9. What are the parameters influencing propagation of environmental noise?
10. What you mean by Equivalent Continuous Sound Pressure Level ?

**PART B***(Answer one full question from each module, each question carries 14 marks)*

11. (a) Why do we need models? Explain with an example (5 Marks)  
(b) Discuss various types of models used in environmental science (9 Marks)
- OR
12. (a) Reliability of a model does not necessarily increase with model complexity. Why? (5 Marks)  
(b) Discuss the model building framework (9 Marks)
13. (a) An air sampling station is located at an azimuth of  $203^\circ$  from a cement plant at a distance of 1500 meters. The cement plant releases fine particulate matter at the rate of 94.5 g/s from a 30 meter high stack. What is the contribution from the cement plant to the ambient particulate

matter concentration at the sampling station when the wind is from  $30^\circ$  at 3 m/s. Given that  $\sigma_y = 150\text{m}$  and  $\sigma_z = 87\text{m}$  (9 Marks)

- (b) What is plume rise? How it influences air quality modelling? (5Marks)

OR

14. (a) How stability parameters used in Gaussian model are determined? (5 Marks)

- (b) Discuss in detail various air quality models and their use (9 Marks)

15. (a) Briefly discuss the historical development of water quality models (9 Marks)

- (b) What input data are needed for sediment transport modelling (4 Marks)

OR

16. (a) The initial BOD of a river just below a sewage outfall is 25 mg/L. The oxygen deficit just upstream from the outfall is 2 mg/L. The deoxygenation rate coefficient  $k_d$  is 0.4/day, and the reaeration rate coefficient  $k_r$  is 0.7/day. The river is flowing at a speed of 30 km /day.

- (i) Find the critical distance downstream at which DO is a minimum

- (ii) Find the minimum DO (9Marks)

- (b) Explain low flow analysis (5 Marks)

17. (a) An aquifer has a cross section with a horizontal width of 265m, and a vertical thickness below the water table of 42m. The water table is 36 m below the ground surface. Each day 3340 m<sup>3</sup> of water is discharged through the cross section. The aquifer rock has an effective porosity of 27.1%. Find the Seepage velocity through the aquifer (5 Marks)

- (b) Discuss the basic mechanisms that drives the contaminant transport in ground water (9 marks)

OR

18. (a) What are the contaminant, soil and site properties and their combinations that are critical in the transport of contaminants to ground water (5 Marks)

- (b) The distance from the base of a pumping well to the freshwater-saltwater interface is 100 m, the pumping rate is 3000 m<sup>3</sup>/day, and the hydraulic conductivity is 10 m/d.

- (i) What will be the position of the interface?

- (ii) What's the maximum permitted pumping rate for the well? (9 Marks)

19. (a) Discuss the need for environmental noise modelling (5 Marks)

- (b) Explain noise mapping methodology (9 Marks)

OR

20. (a) Explain the noise generation mechanisms (5Marks)

- (b) Discuss how traffic noise can be modelled? (9 Marks)